

EG SERIES ELECTRIC POWERED SCREW AIR COMPRESSOR

EG 11 to EG 22

(15 HP to 30 HP)

Standard and Standard + VFD

208 - 230V / 460V, 3Ph, 60Hz

OPERATION AND MAINTENANCE MANUAL

Part / Document No. 019400022 Rev R08

Print Status

April 2017

List of Contents

OPERATION AND MAINTENANCE MANUAL

Introduction	5
Salient Features	7
Safety	8
Operating Precautions	8
Technical Specifications	10
Commissioning Process	11
Installation	11
Disposal Of Packing	20
Functional Description	21
Maintenance	27
Maintenance Schedule	41
Decommissioning Dismantling And Putting Out Of Service	42
Disposal Of Consumables And Replaced Parts	42
Troubleshooting	43
Conversion Tables	47
Torque Values	48
Service Log Book	49
Glossary	51

Machine Identification and Sale Record

Owner's Name : _____

Phone Number : _____

Contact : _____

E Mail Address : _____

Model : _____

Serial Number : _____

Year of manufacture : _____

Motor : _____ HP/kW _____

Capacity : _____ cfm _____

Rated Pressure : _____ psi (g) _____

Date of Delivery : _____

Date of Commissioning : _____

Distributor's Name/Address : _____

Distributor's Signature

Using the Manual

This operation and maintenance manual has been specially designed to get the most out of your Elgi EG Series compressor. Before you start using your compressor, go through this manual thoroughly. It contains vital information on operation as well as useful tips that will help you to maintain your compressor as good as new for years to come. It is essential to maintain the compressor as recommended in the maintenance section.

The manual has been prepared with utmost care to help you understand the various systems of the compressor thoroughly through descriptions, information and illustrations.

All the information, illustrations and specifications in this manual are based on the latest product information at the time of preparation of the manual. Elgi reserves the right to make changes in the product at any time without notice.

When calling your Elgi branch office, distributor or service center regarding your compressor, keep at hand the details present on the name plate of the compressor and entered in the inside front cover of this manual.

When ordering spare parts, refer to the lists provided in Parts Manual portion and identify the part number. Specify the part number and quantity in addition to the name plate details.

The manual must be available at all times to the personnel operating the compressor.

Definitions and Symbols

This information is related to your safety and also to preventing any problems relevant to equipments used. To help you recognize this information, we use the following symbols

NOTE:

Note clarifies procedures or conditions which may otherwise be misinterpreted or overlooked. Note may also be used to clarify apparently contradictory or confusing situations.

CAUTION:

Caution is to draw attention to a procedure which, if not done correctly, can lead to equipment damage.

WARNING:

Warning calls attention to dangerous or hazardous conditions inherent to the operation, cleaning and maintenance of the equipment which may result in personal injury or death of the operator or other persons.

SYMBOLS:



CAUTION



DO NOT OPERATE



CAN CARRY OUT REPAIRS OR ADJUSTMENT



WARNING



DE-ENERGISE



KEEP ACCESS DOORS CLOSED



OPERATION



DO NOT ATTEMPT REPAIRS



DO NOT INHALE



ENERGIZED (POWER ON)

Message from the Managing Director

Dear Elgi Customer,

It gives me great pleasure to welcome you to the family of users of EG Series compressors from Elgi , among the most sophisticated rotary screw air compressors available in the world today.

Elgi has designed your EG Series compressor to be reliable, safe, easy to maintain and friendly to use in meeting your compressed air requirements. This user manual will enable you to use the EG series compressor optimally. Please familiarize yourself with all the information it contains.

I look forward to your continued satisfaction as a EG series user. Elgi is honored to be your choice for all your compressed air needs.



Yours sincerely,

Jairam Varadaraj

Managing Director

About Elgi

Elgi, established in 1960, designs and manufactures a wide range of compressors. The company has gained its reputation for design and manufacture of screw compressors through strategic partnerships and continuous research and development.

Screw compressor elements are manufactured in-house using state-of-the-art machining centres for rotor grinding and machining castings of various sizes. Elgi's own eta-V profile rotors ensure energy-efficient compressed air supply for all demanding applications. Elgi is one of the few companies capable of manufacturing wide range of airends and compressor packages in the world. Elgi's patent portfolio is a testament to the company's continuous research and innovation capability.

Elgi has modern manufacturing facilities in equipped with advanced high precision grinding machines, turning centres and CNC horizontal and vertical machining centres. Screw airends are manufactured with the latest rotor grinding technology, coupled with measurement technology to maintain precise manufacturing tolerances. Elgi's manufacturing plants are both ISO and EOHS certified.

Elgi serves the world marketplace. Over two million compressors are powering business in 63 countries worldwide. The company offers a strong sales and service network with a well-knit distribution network of dealers and distributors worldwide. Elgi has its own manufacturing facilities in China, France, India and Italy. Additionally, Elgi has warehouse operations to stock units and parts in Australia, Brazil, UAE and USA.

EG Series

Your EG Series compressor belongs to a family of rotary screw compressors from Elgi. The compressor has only two moving parts the rotors which are separated by a thin film of oil, so that there is no wear. This also means that the reliability of the compressor is unsurpassed.

The screw compressor technology ensures that there is no reduction in output capacity even after many years of operation. It involves a continuous flow of air through helical cavities in the screw and so the compressed air delivery is pulsation free.

The design of the EG Series gives you a compact and self-contained compressor. Because it has no reciprocating parts, it runs quietly and free of vibrations. The discharge temperature of the coolant oil is low, less than 195°F, under normal conditions and therefore carbonized oil is not formed in the compressor.

Salient Features

- * Two-stage air filter
- * Improved air filter life cycle
- * Silent package suitable for inhouse operations
- * Variable capacity control system
- * High volumetric efficiency
- * Efficient air-oil separation by OSBIC (Oil Separation By Impact and Centrifugal action)
- * Reliable fan which works even at high temperature
- * Isolated cooling system
- * Robust cooling system
- * Industrial designed canopy
- * Compact and occupies less space
- * Split type oil coolers for easy serviceability
- * Flush type panels for easy handling
- * Anti-vibration mounts restricts vibration
- * Increased life of consumables
- * Integrated VFD (Variable Frequency drive) and Dryer.
- * Zero leak flanged joints.
- * Oil Carry over < 1 ppm
- * Advanced Neuron II Controller
- * Globally Certified product - CE / UL and other Country specific approvals.

Safety

- * The operator should follow the instructions, procedures and decals given in this manual for safe operation
- * The maintenance personnel should be adequately trained, and have read and completely understood this operation and maintenance manual
- * Compressed air and electricity can be dangerous. To prevent injury before attempting any maintenance, be sure to disconnect the power at the source and the compressor is relieved of all pressure
- * Ensure that all the protective covers are in place and that the canopy/doors are closed during operation
- * Remove red colored brackets at the airend, motor and shroud while commissioning the compressor
- * **Danger!** Compressed air used for breathing or food processing must meet O.S.H.A. 1910.134 or F.D.A. 21 C.F.R. 178.3570 regulations. Failure to do so may cause severe injury or death.
- * Do not allow compressed air to come into contact with food and related items unless it is treated specifically.
- * This air Compressor is intended to be used for generating compressed air for industrial use only.



Never start the compressor unless you know it is safe to do so. Do not attempt to operate the compressor when it is known to be in an unsafe condition. Examples of unsafe conditions include improper grounding of the machine and reverse rotation of the motors

Electrical arcing from compressor components can ignite flammable liquids and vapors which can result in serious injury. Never operate the compressor near flammable liquids or vapors. If the compressor is used to spray flammable materials, keep it at least 20 ft away from the spray area

Operating Precautions

Pressure Release

- * Annual servicing of safety valve and the kit is necessary. The kit should be checked at standard pressure
- * Use only the correct tools for maintenance and repair work. Do not exceed the manufacturers' rated safe operating pressure for pipes, valves, filters and other fittings.
- * Open the oil fill cap only when the compressor is not running and is not pressurized. Shut down the compressor and bleed the receiver tank to zero internal pressure before removing the cap
- * Vent all internal pressure prior to opening any line, fitting, valve, drain plug, connection or other components such as a filters. Vent pressure by popping up the safety valve
- * Keep personnel out of the line of the discharged air when opening hoses or other points of compressed air discharge
- * Do not use air at a pressure greater than 35 PSI for cleaning purposes
- * Use ear Protection when compressed air is vented out.



PULL THE RING TO
RELEASE PRESSURE

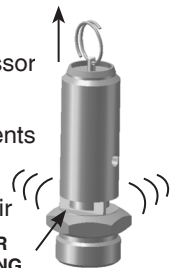

SLOT FOR
RELEASING
THE
PRESSURE



Do not engage in horseplay with air hoses: serious injury or death may result

Fire And Explosion

- * Clean up spills of lubricant or other combustible substances immediately
- * Shut down the compressor and allow it to cool down. Move sparks, flames and other sources of ignition away. Do not permit smoking in the vicinity when checking or adding oil
- * Do not use flammable solvents for cleaning purposes
- * Keep grounded conductive objects such as tools away from exposed live electrical parts like terminals to avoid arcing, which might serve as a source of ignition. Keep all terminals clean and tight
- * Keep electrical wiring and other terminals in good condition. Replace any wiring that has cracked, cut, abraded or otherwise degraded insulation
- * Keep oily rags, trash, dry leaves, litter or other combustibles out of and away from the compressor



- * Do not operate the compressor without a proper flow of cooling air or with an inadequate flow of lubricant or with a degraded lubricant
- * Do not attempt to operate the compressor in a hazardous environment of any classification unless the compressor has been specially designed and manufactured for explosive applications

Moving Parts

- * Keep hands, arms and clothing away from couplings, fans and other moving parts
- * Do not attempt to operate the compressor with the fan guards, coupling guards or other guards removed
- * Keep access doors closed except when making repairs or adjustments
- * Wear snug-fitting clothing and confine long hair when working around the compressor, especially when hot or moving parts such as the cooler, the air end, the thermal valve, the main motor or the fan motor are exposed
- * Keep hands, feet, floors, controls and walking surfaces clean and free of fluid, water or other liquids to minimize the possibility of slips and falls
- * Rotating fan blades can cause serious injury. Disconnect power supply before attempting service



Hot Surfaces

- * Avoid bodily contact with hot oil, hot coolant and hot surfaces
- * Keep all parts of the body away from all points of air discharge
- * Keep a first aid kit handy. Seek medical assistance promptly in case of injury. Do not ignore small cuts and burns as they may lead to infection



Toxic And Irritating Substances

- * Do not use air from the compressor for respiration
- * In the event of ingestion of oils, coolants and lubricants used in the compressor, seek medical treatment promptly. Wash with soap and water in the event of skin contact



Electrical Shock

- * Keep all parts of the body and any handheld tools or other conductive objects away from exposed live parts of the electrical system. Stand on a dry or insulating surface and do not contact any other part of the compressor when making adjustments or repairs to exposed live parts of the electrical system. Make all such adjustments or repairs with one hand. This minimizes the possibility of creating a current path through the heart
- * Attempt repairs only in a clean, dry, well lit and ventilated area
- * Do not leave the compressor unattended with open electrical enclosures. If it is necessary to do so, disconnect the power to the compressor at the source and lock it out so that power is not inadvertently restored
- * Disconnect, lock out and tag the power source prior to attempting repairs or adjustments, turning the machinery manually or handling ungrounded conductors
- * All electrical installation must be in accordance with recognized electrical codes and any local health & safety codes
- * Only authorised and qualified trained personnel should carry out any electrical work on the compressor.
- * Regularly check that all electrical connections are tight and in good condition.



Dos

- * Read the manual in detail and follow the instructions
- * Clean the air compressor package regularly
- * Keep the air filter clean
- * Use only **genuine Elgi spares**
- * Use only clean and recommended lubricants
- * Maintain correct oil level and use proper tools
- * Attend immediately to anything unusual in the air compressor
- * Maintain log book to monitor operation of compressor
- * Attend repairs / service with qualified technicians only

Don'ts

- * Neglect the routine attention
- * Allow any leakage in the system
- * Keep any tools or loose items on the compressor/other modules and Meddle with any adjustments or settings
- * Use cleaning agents, when changing oil and do any repair work while the unit is running
- * Overload the compressor for a long period

Technical Specification

Standard Compressor

Item		Model	EG 11 (15 HP)				EG 15 (20 HP)				EG 18 (25 HP)				EG 22 (30 HP)			
1	Working Pressure	psi.g	100	125	150	175	100	125	150	175	100	125	150	175	100	125	150	175
2	Free Air Delivery	cfm	71	64	57	49	92	85	78	69	116	107	91	80	140	132	112	95
		m ³ /min	2.01	1.81	1.61	1.39	2.61	2.41	2.21	1.95	3.28	3.03	2.58	2.27	3.96	3.74	3.17	2.69
3	Air Discharge temperature	°F	Ambient Temperature + 18															
4	Safety valve set pressure	psi.g	205															
5	Motor power	HP	15				20				25				30			
		kW	11				15				18.5				22			
6	Type of Motors		Squirrel cage induction TEFC & Cooling fan integrated motor															
7	Type of Starter for Main Motor	C	Automatic Star Delta															
		CV	Through Variable Frequency Drive															
8	Speed of motor	rpm	1765															
9	Voltage	C	208 - 230/460															
		CV	460															
10	Frequency	Hz	60															
11	Speed of fan motor	rpm	1490 (208 - 230V) / 1560 (460V)															
12	Fan Motor Power/Fan	HP (kW)	0.35 (0.26) -208 to 230V															
			0.39 (0.29) - 460V															
			11kW - 1 Fan, 15 to 22kW - 2 Fans															
13	Length	inch	56															
14	Width	inch	28															
15	Height	inch	58															
16	Weight	C	1301				1344.8				1499				1521			
		CV	1410				1521				1565				1576			
17	Oil recommended		ELGI Airlube UT Synthetic															
18	Air outlet port size	inch	1" NPT Thread															

NOTE: C - Standard Compressor, CV - Standard Compressor with Variable Frequency Drive
Tolerance for S.No:3 will be +4°F

Commissioning Process

Before the new EG Series compressor is operated for the first time, it needs to be installed at your site according to Elgi's Installation specifications.

The servicing technician carries out a series of checks on the machine and the systems to which it is connected to ensure that it is in a condition to function safely and as desired. He will then describe to the operator of your compressor how the equipment is to be operated and maintained. This procedure is referred to as the commissioning process.

The commissioning of your compressor ensures that it is installed safely. The general operating conditions of the equipment including the cleanliness of the atmosphere, the temperature and the ventilation are checked. Technical details relating to your system such as particulars of your electrical installation are noted. The operator of your compressor is familiarized with all aspects of both its normal running and dealing with unusual situations.

Please make preparations according to the instructions provided in the Installation section for your EG Series compressor to be commissioned. Ensure that the location chosen meets the requirements of accessibility, ventilation and safety. Provide electrical power as recommended in the Installation section. Select air pipe lines and receivers for your system according to the tables provided in the same section.

Upon completion of the commissioning process the technician will fill in the document known as the commissioning report and the warranty card.

Unpacking

Unpack the compressor from the packing case by removing the nails. Unscrew the bolts holding the compressor to the base of the crate

Once all the packing material is removed, check the contents against the packing list. The compressor is shipped with the following:

- * Key for doors
- * Operation and maintenance manual
- * Checklist of parts of the machine
- * Electrical drawing

Tools may be provided on request. If any components are found missing, contact Elgi immediately

Installation

Handling the compressor

EG Series compressors can be lifted either using forklifts or cranes. Please refer to the figures below for general guidance

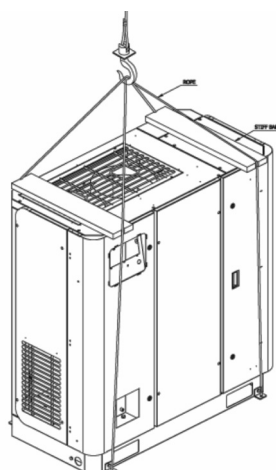

Option 1

- * If the compressor is provided with a lifting hook then lift using the hook as shown in image. If no hook is provided, lift it using slings.
- * Prior to lifting, inspect the lifting hooks and points of attachment for any cracks in hooks and in welds, any abnormal bends, corrosion of parts, loosening of bolts & nuts.

Operation and Maintenance Manual

- * Make sure the entire lifting, rigging and supporting structure has been inspected, is in good condition and has a rated capacity of at least the net weight of the compressor. If you are unsure of the weight, then weigh the compressor before lifting it.
- * Make sure the lifting hook has a functional safety latch, or equivalent, and is fully engaged and latched on the hook.
- * Use guide ropes or equivalent to prevent twisting or swinging of the machine once it has been lifted completely off the ground.
- * When the compressor is lifted up by crane, use cushioning materials at the four points of the bottom for prevention of damaging the cover. Cushion should be padded at 4 lifting points for prevention of damages.
- * If you are using the guide ropes to lift the machine for installation, Ensure that the rope is not touching the canopy at the bottom and top to avoid scratches and rope marks or any other severe marks on canopy.
- * Do not attempt to lift the compressor in high winds. Keep all personnel away from the compressor when it is suspended.
- * Do not lift the compressor higher than the required height.
- * Keep the lift operator in constant attendance whenever the compressor is suspended.
- * Set the compressor down only on level surfaces, capable of supporting at least its net weight plus an additional 10 per cent allowance.

Option 2

- * Apply cushion materials for protecting the packaged unit from being damaged. Confirm that the front edge of the fork is surely put through the holes with the edges of the fork.
- * Make sure the fork lift is capable of handling the weight of the compressor & its two arms is fully engaged with the compressor package as shown in image.

Compressor Location – Space Around Compressor

Install the compressor with adequate accessibility to ensure obstruction-free operation and maintenance. Maintain a clearance around the compressor as mentioned in GA Drawings

Compressor Location – General Requirements

- * The compressor room or the area around the compressor should be clean, dry, cool and free of dust. The room temperature for the compressor should preferably be below 115°F. Excessively warm intake air affects the compressed air output. When the discharge temperature of the compressor (temperature at compression unit) exceeds the factory-set value of 230°F, the compressor will trip off. Also, the ambient temperature should not drop below +40°F. Provide air supply openings with adjustable louvers to ensure that the minimum temperature does not drop below +40°F in winter.
- * Never store combustible materials within a 35ft radius of the compressor. The room housing the compressor must be equipped with fire fighting equipment. The floor around the compressor must be of non-combustible material.
- * Compressor should be Rept on a levelled floor .
- * Remove the Bottom of the Packing case.



Please observe all accident prevention regulations when installing this compressor

Installation

GA drawing – EG 11 to EG 22 (15 HP to 30 HP)

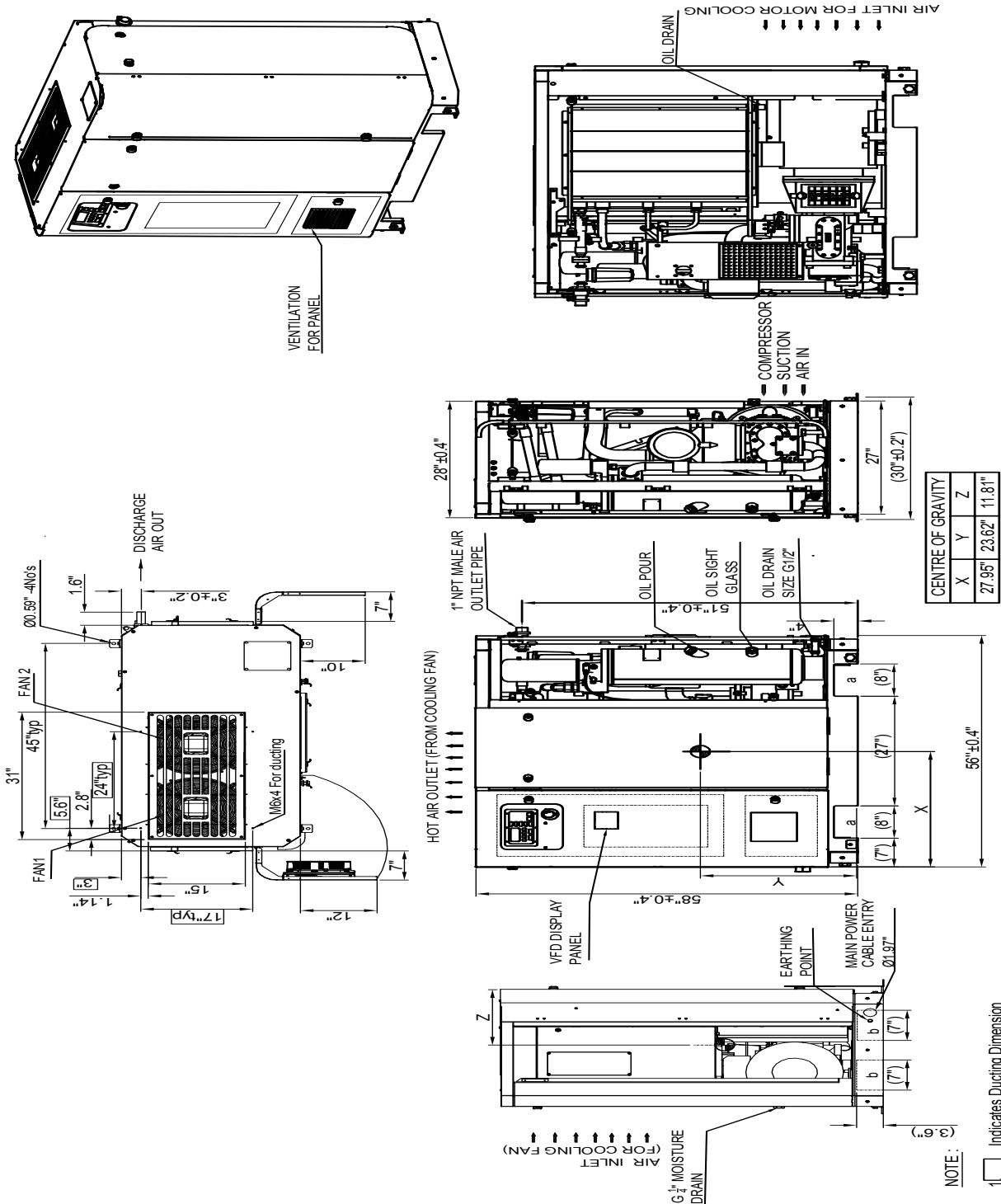

NOTE: A minimum of 3.3 ft clearance is required on all sides of compressor and 6.6 ft clearance above the unit.

Ventilation and Exhausting Hot Air

Ensure adequate ventilation in the compressor installation area. Your compressor has a ventilating air requirement of 247202 ft³/hr. The figure provided indicates different ways in which this could be achieved

If your compressor is fitted with ducts as shown in the figure, the ventilating air requirement is only a third of the value specified herein

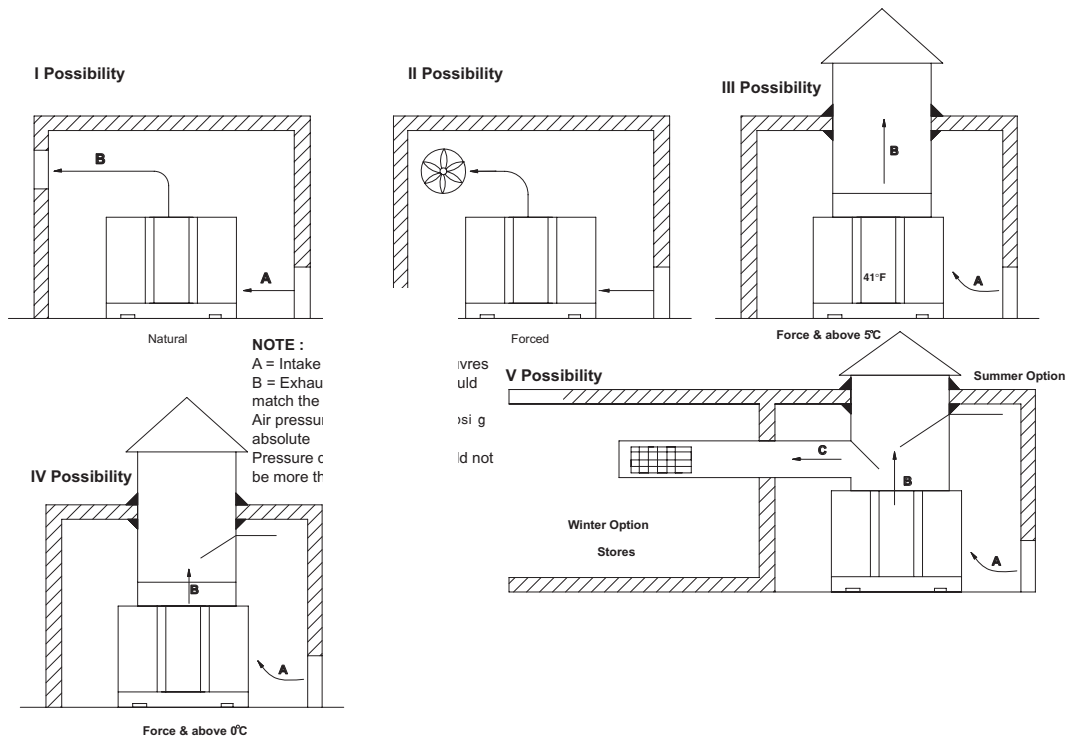

NOTE: Suspended particulate matter should be less than 150 spm to achieve the specified consumable life
No guarantee shall be given if the compressor is operated above its intended pressure

Follow the guidelines herein for providing ventilation for the compressor

- * Provide openings close to the floor level on walls/partitions close to the air suction side of the compressor
- * Provide exhaust openings close to the ceiling for hot air exit
- * To eliminate transmission of vibrations, provide a soft bellows connector between the duct and the compressor
- * Contact Elgi in case you need to provide a duct connection or filter fitment on the compressor
- * The compressor is to be located such that the hot air from other machines is not directed towards it
- * Provide adequate lights for easy reading of displays and see the parts clearly when doors / panels are opened.

Foundation

An industrial floor with a level surface capable of supporting the weight of the Compressor (refer to the technical specifications) is sufficient for installing a EG Series compressor.

Electricals

You must provide a lockable main switch with pre-connected slow-blow main fuses as per industrial safety regulations. The power supply should be 460 Volts 3 phase with Earth (PE). The fuse and cable specifications for 460 V, 60 Hz ,3 PH power supplies are listed in the table below.

Global Series	E11	E15	E18	E22
Motor Power (kW/hp)	11/15	15/20	18.5/25	22/30
Power Supply	208V 60Hz 3PH			
Nominal Current (A)	45.1	61.6	77.2	92
Cable Material	Copper Conductor only			
Power Supply Cable (AWG) (L=15ft)	4X8	4X6	4X4	4X4
Upstream fuses (A) (Type RK/CC/J)	63	80	100	125
Switching Fuse Unit (A)	63	100	100	125

Global Series	E11	E15	E18	E22
Motor Power (kW/hp)	11/15	15/20	18.5/25	22/30
Power Supply	230V 60Hz 3PH			
Nominal Current (A)	43.2	58.6	70.8	84.4
Cable Material	Copper Conductor only			
Power Supply Cable (AWG) (L=15ft)	4X8	4X6	4X4	4X4
Upstream fuses (A) (Type RK/CC/J)	63	80	100	125
Switching Fuse Unit (A)	63	100	100	125

Global Series	E11	E15	E18	E22
Motor Power (kW/hp)	11/15	15/20	18.5/25	22/30
Power Supply	460V 60Hz 3PH			
Nominal Current (A)	21.6	28.9	35.4	42.2
Cable Material	Copper Conductor only			
Power Supply Cable (AWG) (L=15ft)	4X12	4X10	4X8	4X8
Upstream fuses (A) (Type RK/CC/J)	32	40	50	63
Switching Fuse Unit (A)	32	63	63	63

NOTE: Power should be supplied to the compressor through a fuse switch unit of suitable rating mounted within 15 ft of the compressor

Air Pipe Lines

Use the table below as guidance for selecting pipes for your system

Commercial steel pipe size for compressed air line / air pressure losses in 100 ft length															
Free air (cfm)	1/2 inches			3/4 inches			1 inches			1 1/4 inches			1/2 inches		
	80 lb	100 lb	125 lb	80 lb	100 lb	125 lb	80 lb	100 lb	125 lb	80 lb	100 lb	125 lb	80lb	100 lb	125 lb
10	0.45	0.38	0.31	0.11	0.09	0.08	0.04	0.03	0.02	0.0086	0.0071	0.0058			
20	1.74	1.42	1.17	0.41	0.34	0.28	0.13	0.1	0.08	0.032	0.026	0.021	.014	0.12	.010
30	3.84	3.13	2.54	0.9	0.74	0.6	0.28	0.23	0.19	0.068	0.056	0.046	.031	.026	.021
40	6.93	5.55	4.53	1.55	1.28	1.05	0.46	0.38	0.31	0.116	0.096	0.079	.053	.044	.036
50	10.7	8.65	7.01	2.42	2	1.62	0.73	0.6	0.49	0.18	0.046	0.12	.081	.067	.055
60				3.47	2.84	2.33	1.02	0.84	0.69	0.25	0.21	0.17	.12	.095	.078
70				4.73	3.85	3.14	1.36	1.12	0.92	0.34	0.28	0.23	.16	.13	.10
80				6.14	5.01	4.08	1.76	1.44	1.18	0.44	0.36	0.3	.20	.16	.14
90				7.75	6.4	5.17	2.23	1.85	1.49	0.55	0.45	0.37	.25	.20	.17
100				9.62	7.8	6.33	2.69	2.21	1.81	0.66	0.55	0.45	.30	.25	.20
125				15.5	12.4	9.8	4.18	3.41	2.79	1.03	0.85	0.69	.46	.38	.32
150				23	18.1	14.4	5.75	4.19	3.99	1.47	1.2	0.99	.65	.54	.44
175							1.81	6.8	5.45	2	1.64	1.32	.90	.73	.60
200							10.9	8.79	7.11	2.58	2.12	1.73	1.15	.95	.78
250													1.82	1.48	1.20
300													2.55	2.10	1.72
350													3.53	2.86	2.35
400													4.53	3.70	3.03
450													5.80	4.65	3.80
500													7.12	5.79	4.71

Receivers for Compressed Air Systems

The table below is given for your guidance in selecting an appropriate air receiver for your system.

Receiver specifications					Compressed capacity	
Volume		Height	Diameter	Weight	On/Off control	Modulation Control
m ³	ft ³	inches	inches	kg	cfm	cfm
0.25	8.83	68.5	25.7	115	Up to 40	Up to 60
0.5	17.66	82.6	30.7	210	41-85	61-120
1	35.32	109.6	39.3	344	86-140	121-235
1.5	52.97	98.4	49.2	783	141-225	236-355
2	70.63	125	49.2	954	226-310	356-470
3	105.95	110.4	61.6	1308	311-445	471-710
4	141.26	141	62.8	1564	446-570	711-945
5	176.58	139.2	70	2129	571-700	946-1180
6	211.89	164.7	70	2343	701-850	1181-1415
7	247.21	143.3	82.6	2885	851-990	1416-1650
8	282.52	156.8	82.6	3115	990-1130	1651-1885

Earthing

Check the total power supply requirements from the name plate before connecting the compressor to the electrical lines

Connect the earthing line to the point provided on the base frame at the side of the compressor

Connect the leads L1, L2, L3 and PE to the terminals inside the electrical control panel of the compressor as shown in pic below:



Ensure that only authorized electricians carry out the electrical work. Study the electrical circuit diagram before starting work. Transformer tapings & OLR settings need to be adjusted according to voltage conditions (230V / 460V) at site.

- * Connect the compressor to the air network
- * Use Elgi recommended Air lube UT Synthetic oil for optimum performance of the compressor

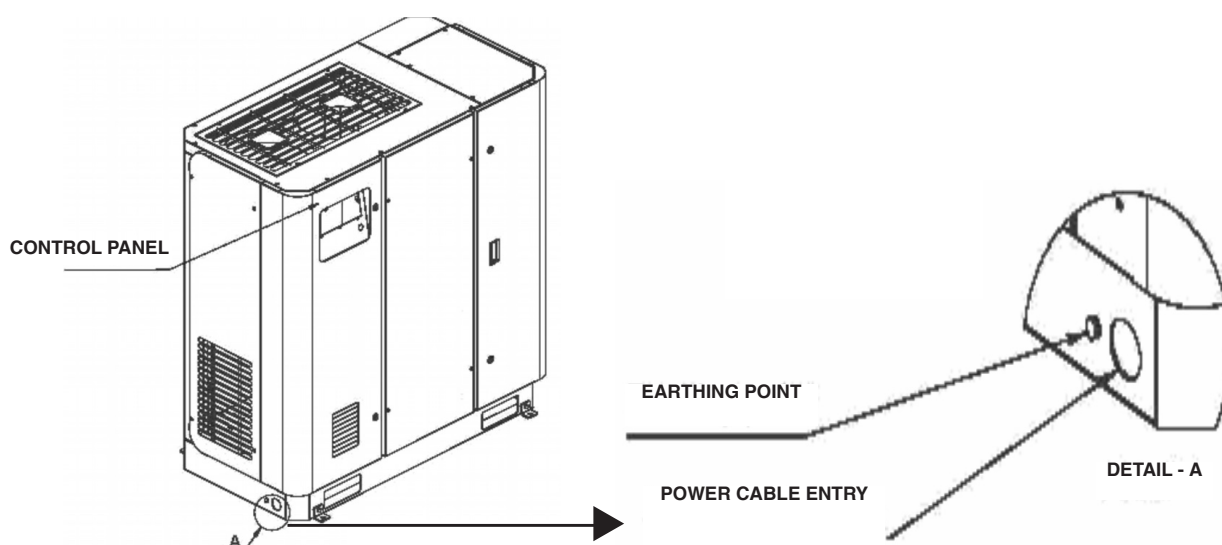

Removal of the Antivibration Mount and shroud Arresting bracket

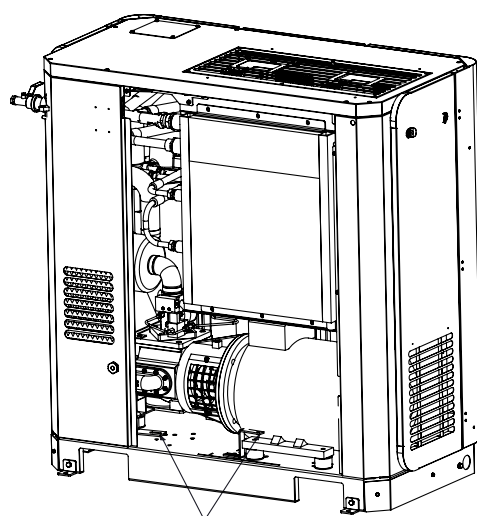

LOCKING CLAMPS AND LOCKING BOLTS
FOR MOTOR AND AIREND (TO BE REMOVED AFTER
THE COMPRESSOR IS INSTALLED)



Remove AVM arresting brackets from Motor and Airend side once compressor is installed

Oil Fill Procedure

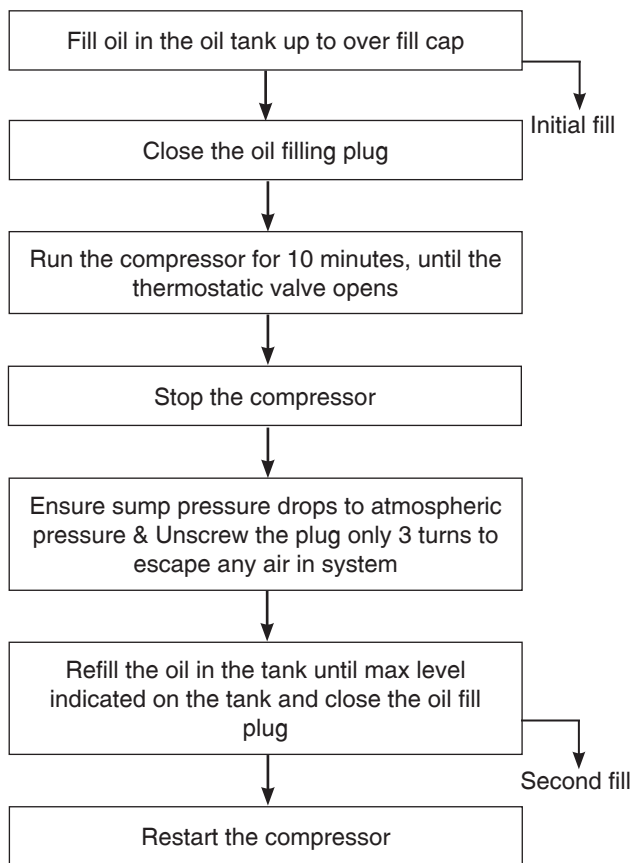
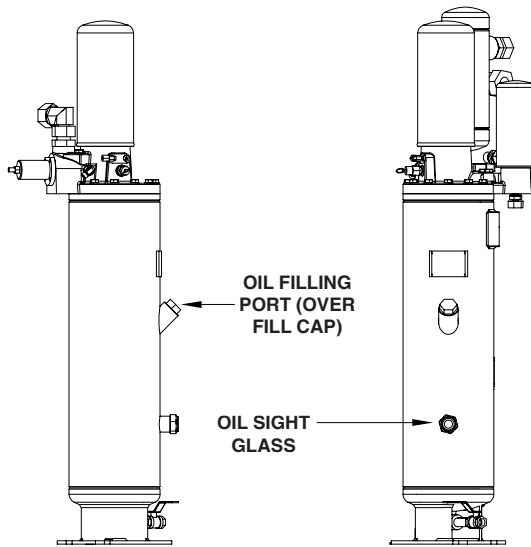

Oil Level Check

- * Oil level should be above oil sight glass after fumes settle down post shutdown
- * Ensure that the oil level sight glass and eye vision is parallel while checking the oil level to avoid parallax errors.

NOTE: Refill the oil in the tank if the level falls below minimum level

Installation

Keep the air outlet line ball valve in fully open condition before starting the compressor

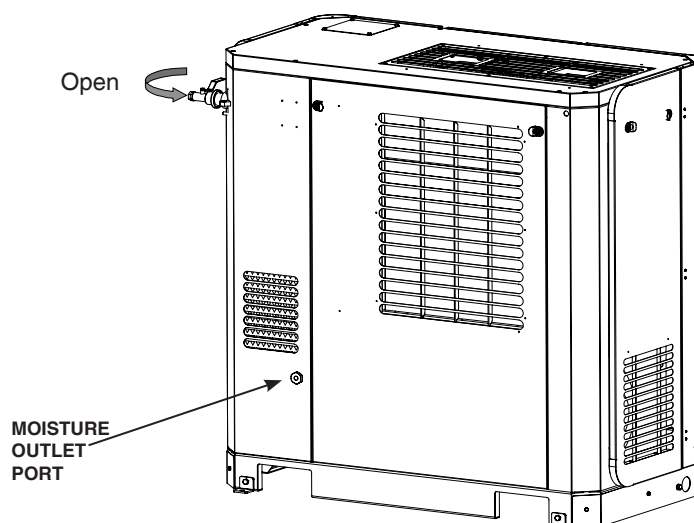

Connect the moisture outlet line provided at the side of the compressor as shown in above figure to the waste water disposal line.

Check the direction of rotation of the main motor when starting for the first time by switching ON the compressor (pressing the green Start button) and switching OFF (pressing the red mushroom Stop button) immediately. The motor must rotate in the clockwise direction when viewed from the main motor fan cooling side. If the direction of rotation is not correct, isolate the machine from the electrical lines and interchange any two phases. Re-start the compressor and ensure that the direction of rotation of the main motor and the fan motor is clockwise

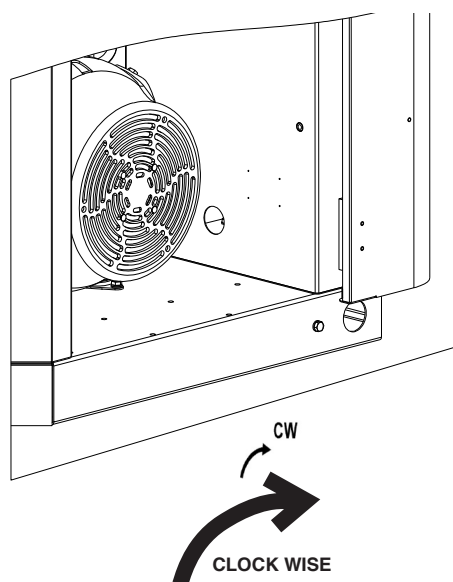

IMPORTANT

After connecting incoming electrical phase lines, please check if both the LED's of Single Phase Preventer (SPP) in the control panel glow. This ensures correct incoming wiring sequence and the compressor is ready for start. If it is not set right, flip the incoming phases for correct wiring sequence

Switch "ON" the compressor after ensuring all the safety points

- * In case of problems during the running of the compressor, check which warning LED's are illuminated on the control panel of the compressor and refer to the Functional Description and Operation sections of this manual
- * If any abnormal noise is heard when the compressor runs, switch it off immediately and contact the Elgi service engineer for remedy
- * All the points listed earlier should be followed, when the compressor is re-installed at a different location
- * If the compressor has been stored for an extended period before commissioning, contact the Elgi distributor.



Ensure that only authorized electricians carry out the electrical work. Study the electrical circuit diagram before starting the work



Running the compressor in the wrong direction for more than 5 seconds will cause damage to compressor parts or even total destruction

NOTE: All settings for pressure, temperature, electrical protection devices, etc, are set at factory before dispatch

Extended Storage

- * If your compressor is expected not to be used for a prolonged period, special measures must be undertaken to ensure the protection of the following components: the airend, the Motors, and the Air–Oil sump tank

Airend

- * Remove the airend discharge hose/pipe coupling fitted to the air receiver
- * Rotate the coupling three times so that the oil present inside the airend comes out through the discharge port
- * Block the discharge port completely
- * Remove the inlet rubber duct connected to the intake valve of the air filter assembly
- * Press the puppet intake valve and pour rust-preventive oil (use Castrol DWX 32 or an equivalent grade) into the airend through the intake valve
- * Rotate the coupling five times by hand so that the rust preventive oil spreads all over the bearings, seals and other parts of the airend
- * Drain the rust-preventive oil by opening the discharge port plug fully
- * Refit the hose/pipe coupling on the discharge port
- * Take care to ensure that all the openings are plugged always to avoid dust entry
- * This procedure protects the airend for up to six months storage. It must be repeated every six months during storage

Motors

- * Check the junction box terminals for tightness of the wires
- * Apply Grease on the motor (use Lithium based or equivalent)
- * This procedure will protect the motor for up to one year storage

The sump or air–oil separator tank

- * Remove the entire tank from the compressor after disconnecting it from all hoses, the tank top lid, the minimum pressure valve outlet line, control pulse lines and control switches
- * Clean the tank using DW X 32 oil or equivalent
- * Check the Air–oil separator tank
- * Replace the oil filter element
- * Replace the air filter element

The separator tank may now be stored for up to two years.

Flush the Tank, airend with compressor oil and replace the **separator element** before using the compressor again

Disposal of Packing

The wood used to make the shipping crates of the EG Series compressors is biodegradable.

The polyethylene covers wrapped around the compressor and the polystyrene packing provided around the electrical panels are not recyclable. They must be disposed of in accordance with prevailing environmental laws.

NOTE: For package preservation / long storage Contact ELGI for further details.

Functional Description

Compression in a EG Series compressor

At the heart of the EG Series compressor is the compressor unit or airend, driven by an electrical motor. There are two counter-rotating, intermeshed helical screw elements in the airend, the male rotor and the female rotor.

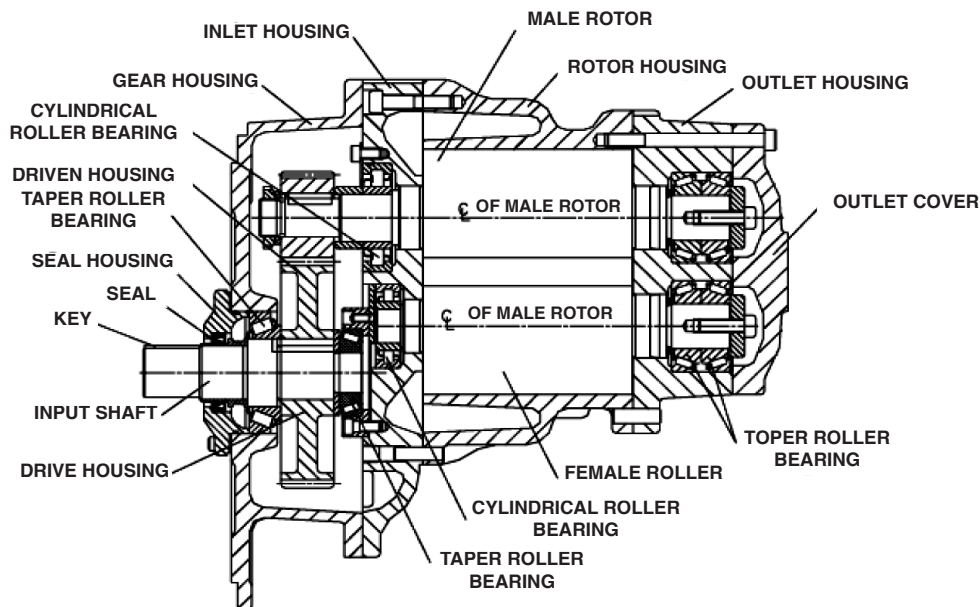

Gear Drive

The rotors mesh with each other as they turn. Air is trapped between the flutes and lobes of the rotors, getting progressively compressed as the rotors turn. The compressed air flows out towards the discharge port. One pocket of trapped air getting compressed progressively is illustrated (next page)

Compression in a screw compressor

In practice, oil is injected in large quantities into the air. It acts as a coolant, removing the heat of compression. It also serves to seal leaks between the rotors and the housing, and lubricates the rotors and the bearings and gears. The oil is separated from the discharge stream, cooled, filtered and then recycled

Internal cooling using oil permits the temperature at the compression and to be maintained at approximately 175°F–185°F at an ambient temperature of 86°F

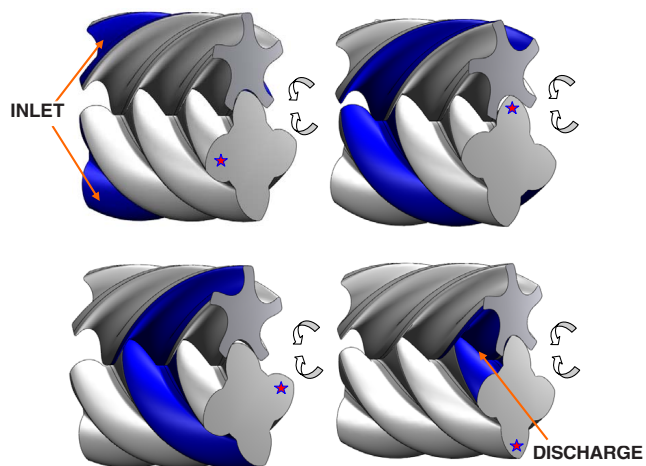

Air Intake System

Air is provided to the airend by the air intake system

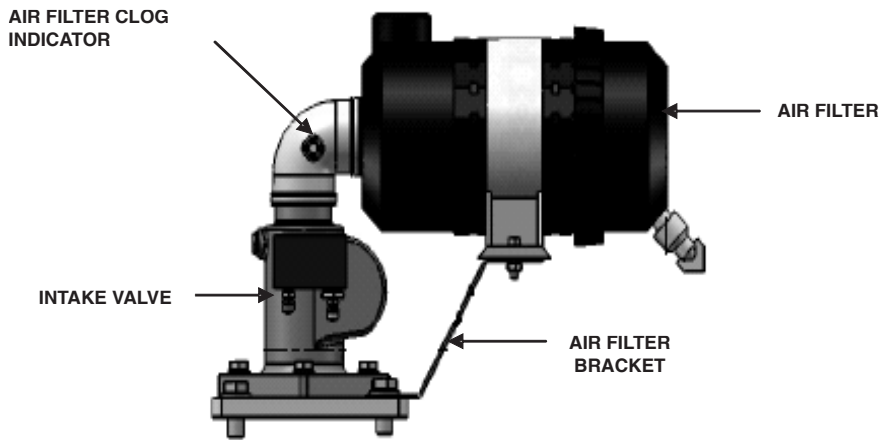

The air filter prevents foreign particles like dust from entering the airend. Air gets filtered in two stages by two different filters namely pre-filter and Air Filter, after which the filtered air enters into the Intake Valve through the Suction hose. The intake valve controls the amount of air passed into the airend. The Air Filter clog indicator mounted on the Air filter side moves to red position when the air filter is clogged indicating a replacement of air filter element.

NOTE: Suspended particulate matter should be less than 150 spm to achieve the specified consumable life
No guarantee shall be given if the compressor is operated above its intended pressure

Drive System

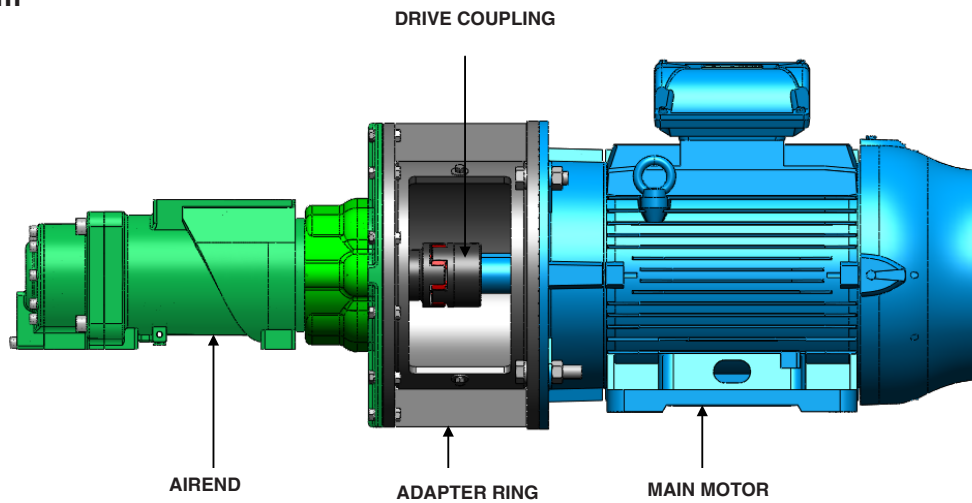

Electrical System and Controls

The Prime mover of the compressor is Electric Motor, which has an automatic star–delta starter with safety interlocks. Ensure that the motor rotates in Clock wise direction. when viewing from non - driving side of the motor. The Power is transmitted to the airend with the help of Claw coupling. The airend derives power from the coupling and Gear, using which it compresses the incoming air from the Intake Valve.

If no fault is detected in the controller, Ready message is displayed. If any fault is detected, trip warning is displayed. The warnings are displayed as described in the electrical system

NOTE: Power should be supplied to the compressor through a fuse switch unit of suitable rating mounted within 15 ft of the compressor

Discharge System

Air oil mixture from air end is subjected to 3 stages of separation in Air-oil separator tank. To bring the oil content to within the desirable limits below 1ppm, the air oil mixture is first pre separated with the help a Deflector. The 2nd Stage separation is a centrifugal action. The Third stage separation is nothing but where the lean mixture is passed through a highly efficient separator element. Even after passing through the Separator element some amount of oil gets collected in the bottom of it, which is returned to the air end through the scavenging or oil return line. The air with 1ppm - 3 ppm of oil passes through the minimum pressure valve (MPV). The minimum pressure valve is positioned downstream of the oil separator. It maintains a minimum pressure which is required for the circulation of oil within the compressor unit during the Starting time. The air temperature at this stage is still higher than the desired temperature at the Air Oil Sump. So it is cooled in an after-cooler to a few degrees above the ambient temperature. Before the air is discharged to the external receiver, moisture is removed with the use of moisture separator..

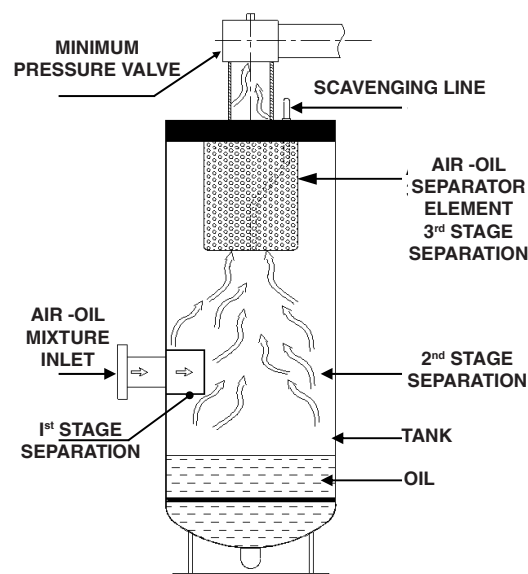

Cooling and Lubrication System

The oil separated from the air-oil mixture is cooled in the oil cooler. A thermal element controls the flow of oil to the cooler, depending on the temperature of the oil. The cooler is bypassed by the oil if the temperature is not high enough, as in the case of initial flow when the compressor is started. The oil is passed through an oil filter which removes dust and other impurities before it is returned to the Air End. The oil circulation circuit is operated solely by the differential pressure and does not require any separate oil pump

As stated previously, the oil has a critical function in the compressor. It removes the major part of the heat of compression, seals all the areas in the Air End and lubricates the bearings and gears. The properties of an oil that determine its suitability for use in the compressor include its viscosity, wear characteristics, demulsibility, heat resistance and thermal stability.

Elgi Air lube UT Synthetic oil with the right amounts of additives under strict quality control checks, ensures satisfactory compressor performance

A good record of the operating temperature of the compressor is essential for this. Continuous operation of the compressor at a temperature above 212°F without changing the oil will lead to varnish formation and will affect the life of the bearings and the aierend.

The below figures are guidelines based on extensive trials in the field. However, Elgi's Service Engineers can help you optimize the oil drain interval for your application based on the operating temperature and pressure and the environmental conditions

Do not mix different brands or grades of oil, this may lead to oil foaming and deterioration in performance or may damage the compressor

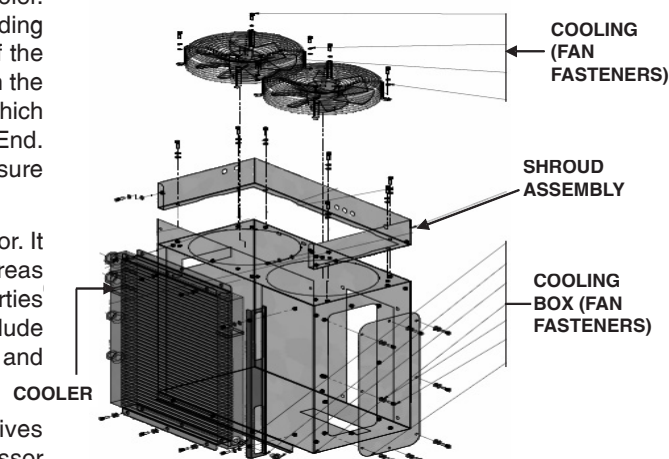

DOT Status	DRAIN PERIOD (Hours)
	Air lube UT Synthetic 000998067 (1.3 gal) / 000998068 (5.3 gal) / 000998069 (55 gal)
DOT < 212°F	8000
DOT above 212°F	Consult Elgi Dealer

NOTE: Suspended particulate matter should be less than 150 spm to achieve the specified consumable life
No guarantee shall be given if the compressor is operated above its intended pressure

Electrical System

The compressor starter is an automatic star–delta starter with safety interlocks

The compressor can be controlled in all modes (Local, Remote and DCS) by the Neuron II, a dedicated microcontroller. Neuron II has eight digital inputs, three analogue inputs and eight relay outputs. The inputs are provided by contact switches, pressure and temperature transducers. Neuron II control panel has eight tactile push-buttons, a 16x2 line alphanumeric LCD for display of compressor status and related information, and 14 LEDs (Annunciation Window) for user interface. If all the inputs are normal, the display indicates “**READY**”

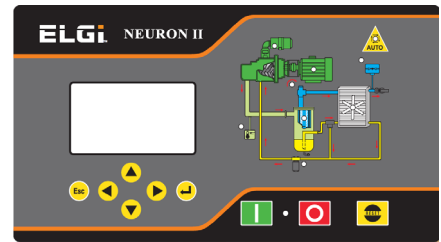

To start the compressor, press the “**START**” (green) push - button located on the controller. The controller will switch on the relays in the correct order, and these in turn will energize the delta contactor and the solenoid valve. The LCD display will show the current status of the compressor. The compressor runs and builds up pressure

To stop the compressor, press the STOP (red) push - button. If the machine trips due to a fault, press the Reset button after rectification the fault.

Preprogrammed timer functions

- * Star-delta delay -determines the star-to-delta changeover time; set at any value between 6 and 10 seconds
- * Delta-to-run (DTR) delay-decides the delay between the delta change over and energizing of the solenoid valve
- * Standby time (unload monitoring time)-stops the compressor if it is running in unloaded condition for a set time (5 minutes) and starts the compressor automatically on demand

NOTE: Ensure 24 V AC power supply to controller. Modify the timer settings under m/c settings menu present in the controller according to requirement. Before starting the compressor, check the following electrically.

Separator element Warning

Indicates that the separator element needs to be replaced. The compressor does not shut down automatically in this situation.

Oil Filter Warning

Indicates that the oil filter element needs to be replaced. The compressor does not shut down automatically in this situation.

High Temperature Discharge

The compressor shuts down automatically and this warning light goes on when the discharge temperature exceeds the preset value of $230\pm 41^{\circ}\text{F}$.

Main Motor Overload Trip

This warning lights up and the compressor shuts down when the main motor is overloaded.

Fan Motor Overload Trip

The fan motor has internal thermal over load protection which safe guards the fan motor. If the fan motor trips then DOT will be high and tripped the compressor as high temperature.

Graphic Warning Display

This gives graphically the location of a fault (condition requiring a Warning)

Reset Button

This button must be pressed before restarting the compressor after it has shut down with a warning and remedial measures have been taken.

Safety System and Interlocking Devices

Your EG Series compressor is equipped with the following devices for reliability and safety:

Discharge Temperature Sensor

This is provided to shut down the compressor if the discharge air– oil mixture temperature reaches a preset value of 230°F . The temperature probe is fitted in Air end.

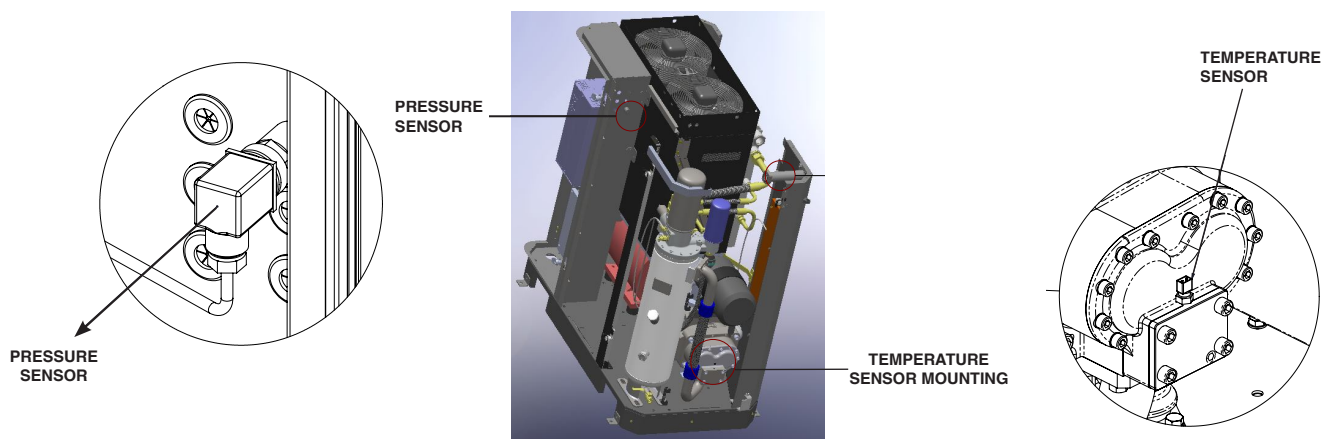

Minimum Pressure Valve

This valve is fitted at the outlet of the oil separator and opens at a defined set pressure.

This facilitates proper air and oil separation and oil circulation to the air end

Safety Valve

The safety valve relieves the pressure in the air–oil receiver tank when it exceeds 175 psi.g.

Overload Relays for Main Motor and Fan Motor

These relays are fitted on the electrical control panel. They ensure the compressor is switched off when the power consumption exceeds a set value.

Operation - Control System

Checks Before Starting The Compressor

- * Fill oil in the oil tank as per the oil filling procedure
- * Open all doors and visually check the machine for suitability of operation
- * Open the door of the electrical panel at the front of the compressor and check whether the three phases and Earth cables are connected securely (L1,L2,L3 and PE wires)
- * Check the necessary earthing line in the panel / compressor base

Starting The Equipment

Press the start button (green) and check that the main motor turns clockwise (when viewed from the main motor fan cooling side of the compressor). Ensure correct direction of rotation, If not, Stop the compressor by pressing the stop button (red) on the control panel.

Starting and Normal Operation Mode

Capacity control system without Variable Frequency Drive Machine:

When the machine is switched ON the motor runs in the Star mode and switched to Delta mode, during this period the inlet valve remains closed. After switching to Delta mode the solenoid valve energizes and opens the inlet valve and closes the Blow down valve. Thus the machine is started with reduced load on the motor. Now the pressure in the system goes up and the minimum pressure valve opens the pressurized air to the discharge.

Capacity control system with Variable Frequency Drive Machine:

When the machine is switched ON, the speed of the motor gradually increases with in 30 seconds (Ramp up time) with the help of VFD, after which the solenoid valve energizes and opens the intake valve and closes the blow down valve. Thus the machine is started with much reduced load on the motor. Now the pressure in the system goes up and the minimum pressure valve opens the pressurized air to the discharge.

Whenever the machine is operated with VFD, the VFD tunes the frequency thereby adjusting the Speed based on the change in Line pressure.

The incoming flow will automatically reduce because of reduced speed of the motor. Conversely, it increases the speed when the line pressure goes down below target pressure (working pressure).

Refer VFD setting procedure manual for VFD operations.

Unloading Mode

After reaching the maximum “cut out” pressure (Table -1), the pressure sensor senses the pressure and **cuts off** the solenoid electrical supply. As a result of this, the solenoid valve becomes Normally closed (NC) and the blow-down valve opens, which releases the sump pressure to atmospheric pressure and the intake valve closes. The compressor runs, maintaining the minimum sump pressure. The blowdown line is connected to the air filter element for auto cleaning. During every unloading process the blow-down valve releases air, which is routed to the air filter element for cleaning it. This reduces the cleaning requirements of the air filter

Table - 1

Working pressure (psi)	Cut out Pressure (psi)
100	115
125	140
150	165
175	190

Monitoring the Running Condition Of The Compressor

Monitor the indicators on the control panel regularly when the compressor is running. Under the following conditions, the corresponding warning light on the control panel lights up and the compressor stops automatically:

- * High discharge temperature
- * Main motor overload
- * Fan motor overload

Stopping

Press the “STOP” button (red) on the control panel to stop the compressor

To Change the Compressor Settings

Change the compressor settings using the tactile keypad and the LCD Panel on the controller. (Refer to Appendix for details of the control panel and interpretation of the message)

Maintenance

The maintenance of EG Series compressors is minimal but important. The indicators on the control panel of the compressor gives warnings for servicing the suction filter or oil filter element.

Maintenance Schedule

Daily : Prior to starting the machine, it is necessary to check the oil level in the Air Oil Sump (see Starting the compressor in the Operation section). If the level is low add the required amount of oil. If the addition of oil becomes very frequent, a problem has developed which is causing this excessive loss. Refer to the section on excessive oil consumption in the Troubleshooting section for a probable cause and remedy

Once a routine operation has been made, observe the instrument gauges and be sure they monitor the correct readings for that particular phase of operation. After the machine has warmed up it is recommended that a general check on the overall machine and instruments be made to ensure that the compressor is running properly.



Do not remove caps, plugs or other components when the compressor is running or pressurized. Stop the compressor and relieve all internal pressure before doing so.

A check-up is necessary to detect and clean the system of any foreign materials. Carry out the following operations

After every 2000 h of running:

Change the oil filter

After every 4000 h of running:

Change air filter element.

After every 8000 h of running:

Change the compressor oil

Change separator element.

Clean Air Oil Sump.

Note: Grease the motor. Use only a lithium based high temperature grease such as Unirex N3 ESSO (SIEMENS) or ESSO Polyrex EPL (HEBAI) or MOBIL POLYREX EM (WEG). Refer maintenance checklist for greasing intervals.

Maintenance Of Individual Components And Systems

Check all accessories independently to verify that they are functioning as required and replace their components as necessary

NOTE: The number of hours of running after which the filter and separator elements and oil are to be replaced are given as a guideline for normal operating conditions They may vary depending on actual operating conditions.

Oil Filter

Dismantling Method of Existing Oil Filter

- * Isolate the machine from the service line, vent the separator tank pressure and allow it to cool for few minutes
- * Hold the filter shell and rotate it counter - clockwise by hand

Assembly of New Oil Filter

- * Ensure the gasket of the filter is not damaged
- * Clean the seating surface with clean cotton
- * Apply this film of oil on the mating surface of the gasket
- * Return the filter to its original position & rotate it clockwise manually. After tightening, rotate it further by hand for one and half rotation
- * Ensure there are no oil leaks from the mating surface

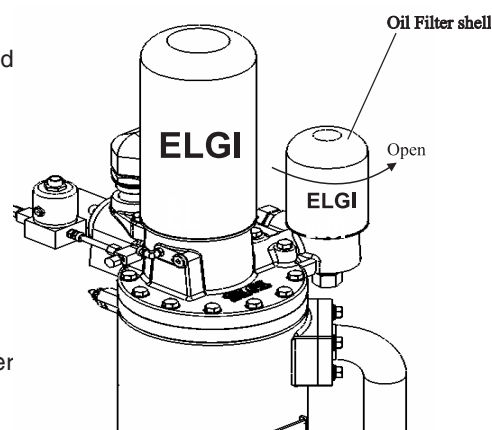

NOTE: Suspended particulate matter should be less than 150 spm to achieve the specified consumable life
No guarantee shall be given if the compressor is operated above its intended pressure

Separator Element

Disassembly of Existing Separator:

- * Switch off and isolate the machine from service line
- * Vent the separator tank pressure and allow it to cool for few minutes
- * Hold the separator outer shell by the removed strap belt & rotate it counter clockwise, until it completely unscrews
- * The helix adapter should be in the separator head during disassembly
- * Check the recommended life of oil separator. Once the recommended life is over, it has to be replaced with a new element

Assembly of New Separator

- * Ensure gasket of the separator is not damaged
- * Clean the gasket-seating surface with a clean cloth
- * Apply a thin film of oil on the mating surface of the gasket
- * Return the separator to its original position & hand rotate it in clockwise direction
- * Ensure there are no oil leaks from the mating surface. In case of leakage, check the gasket
- * After tightening by hand, rotate it further

AIR OIL SEPARATOR SHELL

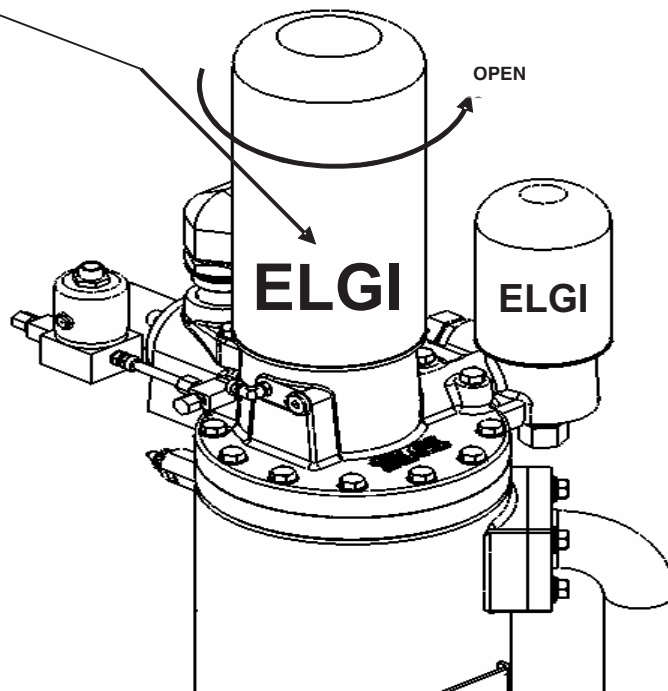

Oil Change Procedure

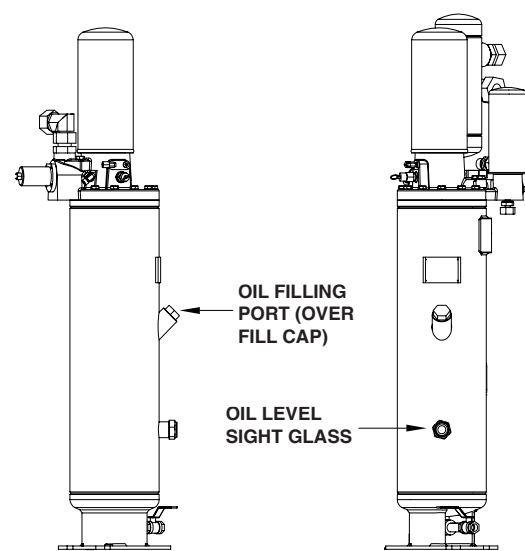
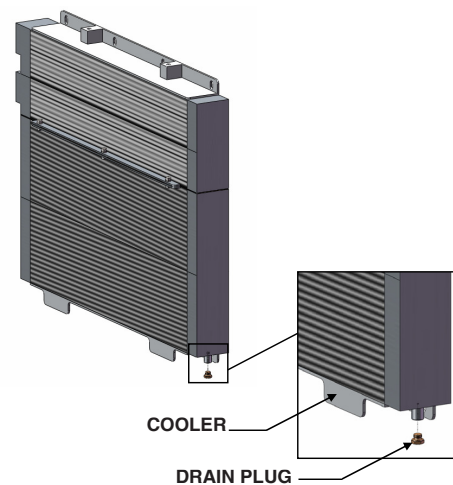
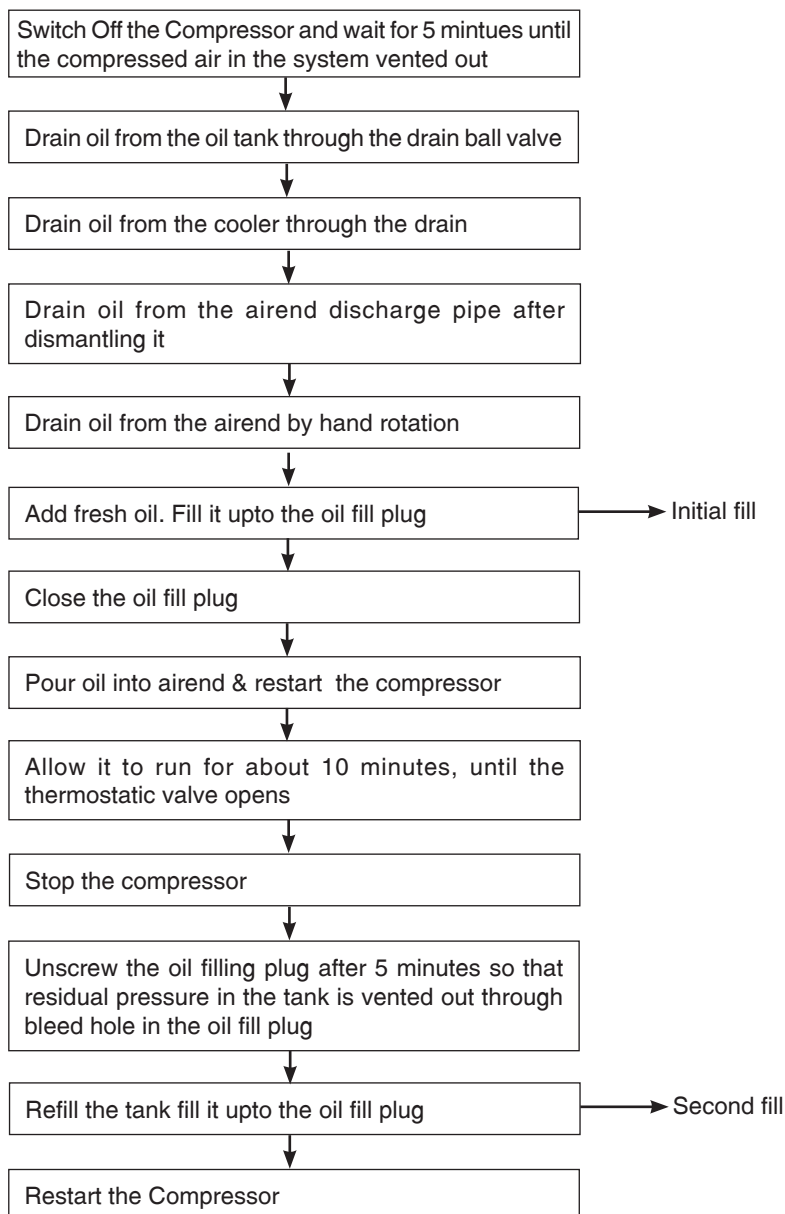

Pre - Filter

Cleaning & Maintenance Instructions

- * Switch off the machine.
- * Refer the Pre-Filter Cartridge Removal & Insert Procedure.
- * Hold or fix the Prefilter assembly in cleaning area.
- * Clean pre-filter with compressed air at less than 2.5 bar g from the reverse or back side of the Pre-Filter Cartridge.
- * In case of Major Dust / Dirt accumulation in the Prefilter element, Wash with clean water or light detergent.
- * Do not use any Acidic / Alkaline chemicals for cleaning.
- * Repeat this process based on dust conditions or regular periodic intervals.

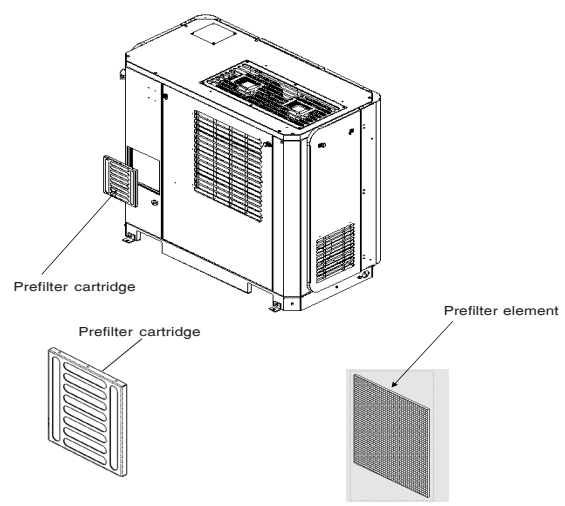

Suction Pre-filter Cartridge Removal Procedure

1

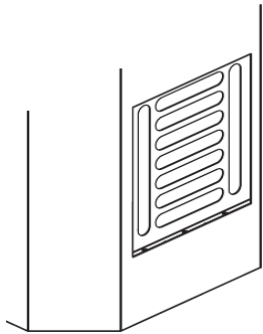

1. Slide Upward

Hold the pre-filter between the louvers and slide upwards slightly until the pre-filter bottom edge is visible

2

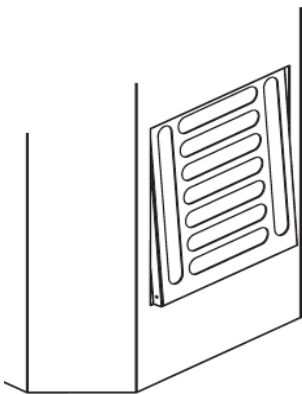

2. Slide Downward

When the pre-filter bottom edge is visible, slant the pre-filter forward and slide it downwards away from the equipment

3

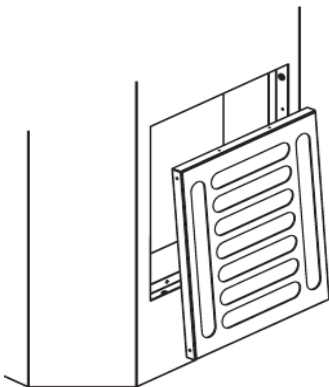

3. Pull Forward

When the top and bottom edges of the pre-filter are free from the equipment, move the pre-filter forward to remove completely.

Suction Pre-filter Cartridge Insert Procedure.

Note : For insert sequence procedure from 3-2-1

Cooler Prefilter -Accessory (Optional)

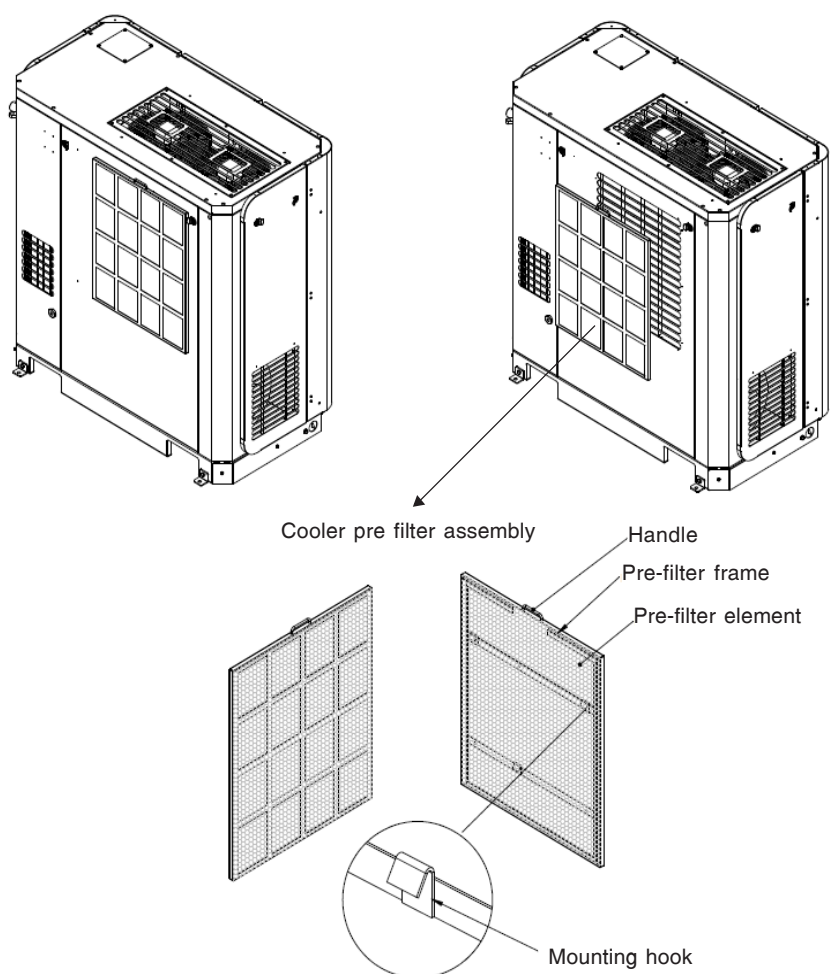

Cooler Prefilter Cleaning & Maintenance Instructions

- * Lift upward & Take out the Cooler Pre filter from the Compressor.
- * Hold or fix the Cooler Prefilter assembly in cleaning area.
- * Clean pre-filter with compressed air at less than 2.5 bar g from the reverse or back side of the Cooler Prefilter.
- * In case of Major Dust / Dirt accumulation in the Prefilter element, Wash with clean water or light detergent
- * Do not use any Acidic / Alkaline chemicals for cleaning.
- * Repeat this process based on dust conditions or regular periodic intervals

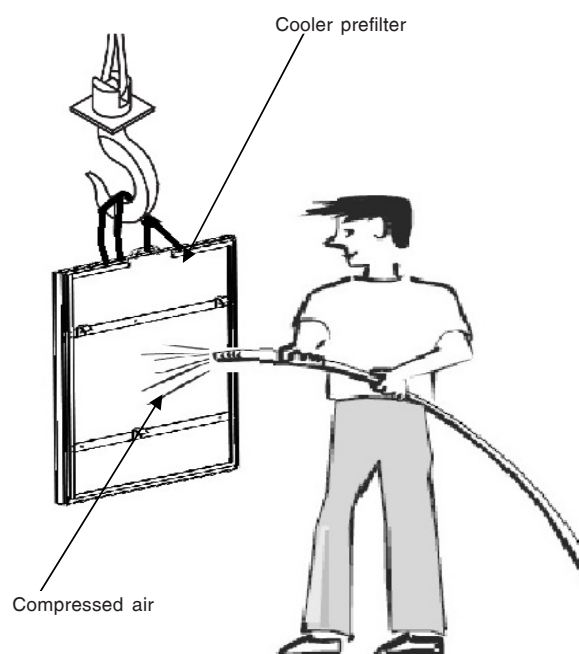

Air Filter

When the air filter clog indicator indicates a blocked condition, remove the air filter by using the clips provided in the housing and replace it with a new air filter.

Clean the air filter using moisture free compressed air at less than 36.3 PSI. The direction of cleaning should be from inside to outside.

Do not forget to reset the Air Filter clog indicator which is fitted in the Intake valve

Shine a bright light from inside the filter element to inspect for damage or holes that will result in leaks. The light will emerge from holes, indicating their locations

Inspect all gaskets and gasket contact surfaces of the housing. Should faulty gaskets be evident, replace the element immediately.

After the element has been installed, inspect and tighten if necessary all air inlet connections prior to resuming operation.

If a clean element is to be stored for later use, it must be stored in a clean container.

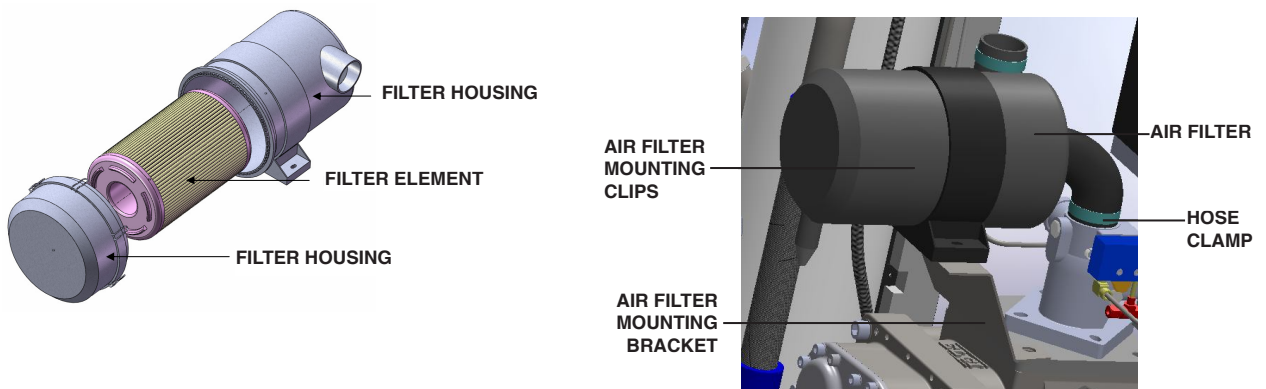

Drive Coupling

- * Coupling is connected in between motor and airend
- * Malfunctioning of coupling element results in sound & vibration

Replacement method of Coupling

- * Isolate the machine from the service line
- * Before attempting maintenance, release the air oil sump pressure and allow it to cool for few mintues
- * Disconnect power supply to the motor
- * Open the coupling guard by using spanner
- * Dismantle the motor from the drive assembly
- * Replace the old coupling element with a new coupling element
- * Assemble the coupling guard
- * Periodic inspection of tightening of screws be done every three months

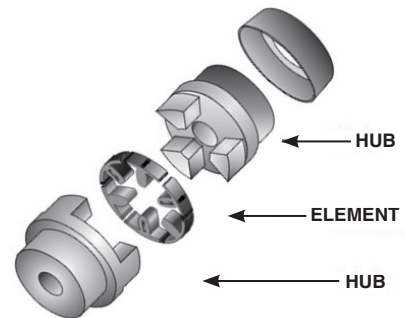

WARNING Disconnect all power at the source before attempting maintenance or adjustments.



WARNING If you need to reduce the operating pressure to save energy, contact Elgi's Service Engineer.

Minimum Pressure Valve (MPV)

- * Isolate the machine from the service line vent the separator tank pressure and allow it to cool for few minutes
- * Release the receiver tank and downstream pressure
- * Unscrew the four bolts
- * Remove the old MPV kit and replace it with a new one
- * Grease the new MPV kit
- * Assemble the MPV kit, and then reinstall the spring and the cap
- * Tighten the bolts
- * Adjust stud protrusion (0.236") to achieve a minimum pressure of 65 psi g



Extreme caution should be taken while removing the cap or cover from the body because of the spring

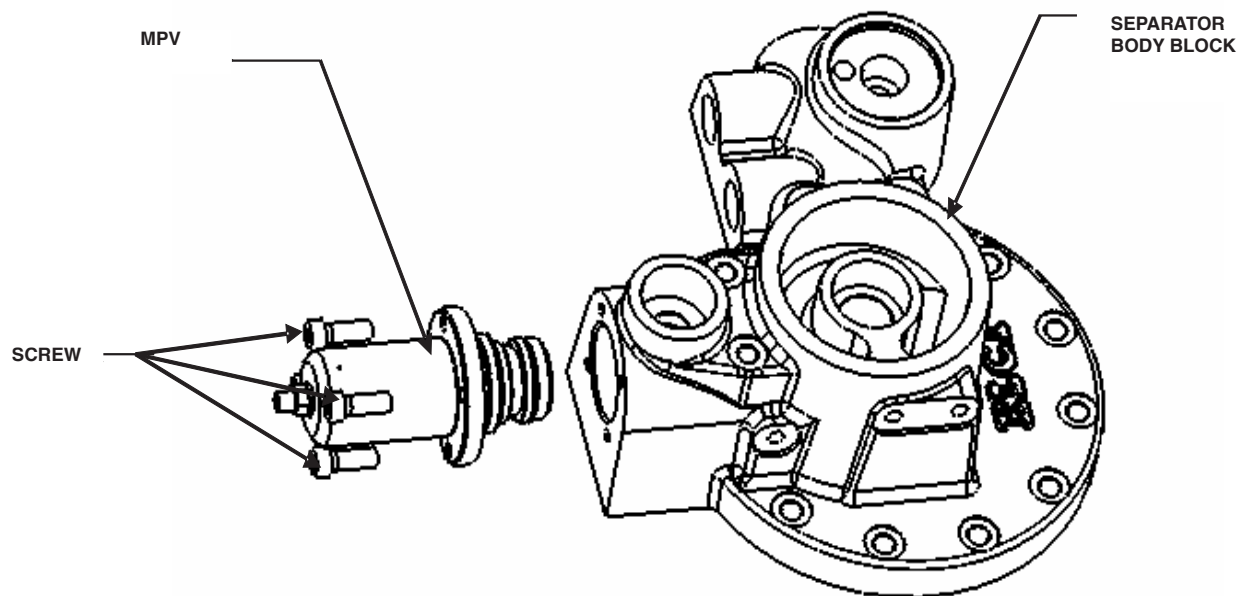

Electric Motor

Frequent Checks

- * Check the insulation of the motor winding
- * Remove moisture from the motor
- * Check the junction box terminals and cable connectors
- * Grease the motor

Greasing Intervals & Recommended Grease

Refer maintenance chart

NOTE:

- * If the compressor is lying idle for more than a year, fresh grease should be applied after removing the old grease
- * The compressor motor IR (Insulation Resistance) value should be verified before starting

Intake Valve

Cleaning

- * Clear rod (12) of Loctite remainders. Clean working area of the piston unit (9) with liquid cleaner and soft cloth. Grease screw drive of rod (12) and piston working area with AUTOL TOP 2000. The flattened medium part of the rod and the thread must be absolutely free of grease. Seat and sealing areas must by no means be damaged.

Reassembly

1. Insert two discs (16+17) into housing according to drawing. The sinter area of the first disc (17) (grey) has to point off the housing in direction to the second steel disc (16). Turn piston unit (9) on rod (12) until stop. Hold rod in a way that the flattened part looks upward. Then turn piston unit back until for the first time a guiding area is parallel with the flattened part of the rod.
2. HAKG: Insert together with spring (6) according to drawing into the housing against the spring pressure, in a way that flattened part points to the counterweight section of the housing.
3. Block rod (12). Install two discs (13+14) acc. to drawing. The sinter area of the first disc (13) (grey) has to point away from the housing in direction to the second steel disc (14). Wet MHT-nut (15) with Loctite 270, lock it and then loosen it again by 1/6 turn. Insert sealing ring (7) in groove provided in the cover (8). Put cover (8) on top and fix it by turning. Connection E must look downward. Loosen blocking of rod.
4. Install control disc (1) according to drawing. The bore for idle operation must always Point at the counterweight section of the housing. Wet Tensilock bolts (9) with Loctite 270 and lock them. Lock with 9 N-m. Install plastic plug according to drawing.

Function Testing

Connect to pressurized air (see data sheet HAK: control air lower pressure range!) and test smooth opening/closing for several times, Adjust by turning MHT-nut (15) in either direction if needed. Pay attention to Loctite (see Lo Loctite - description). If the time is too long, clean Loctite off the nut and wet again.

Intake Valve Service Kits

HAK50 90-663868

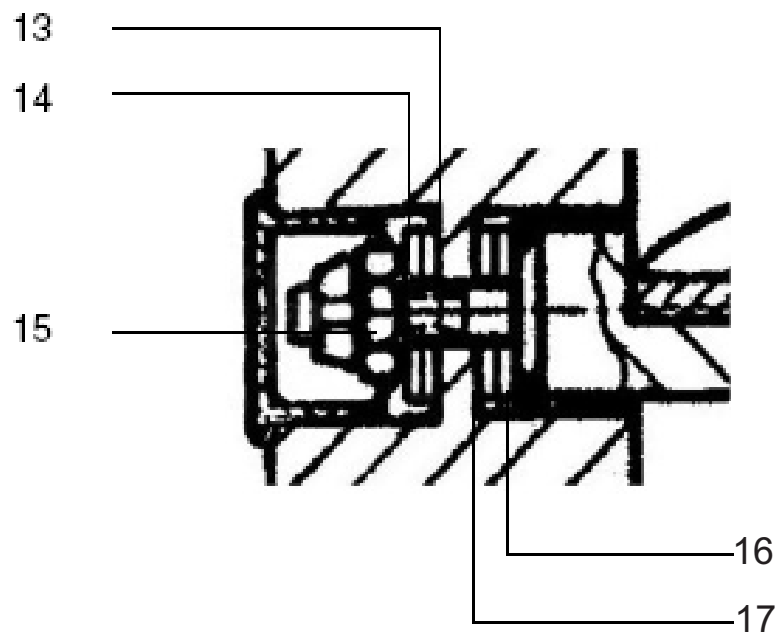
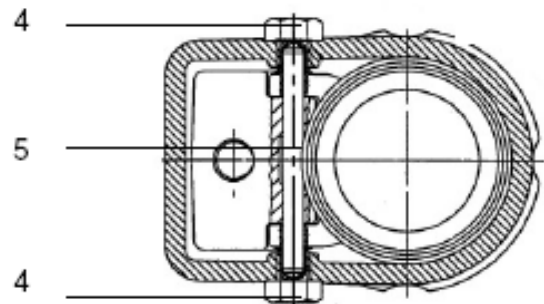
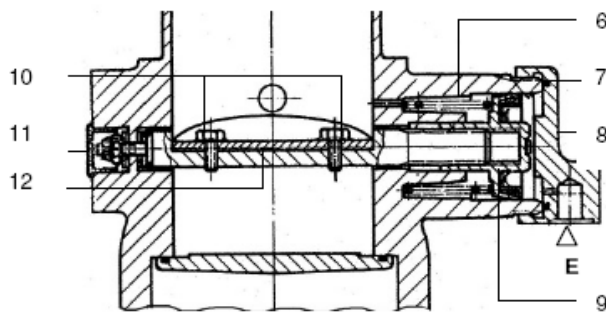
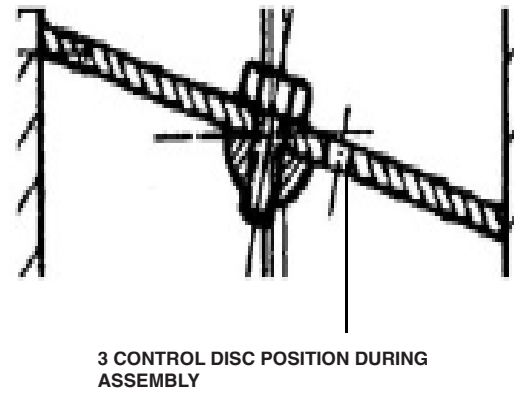
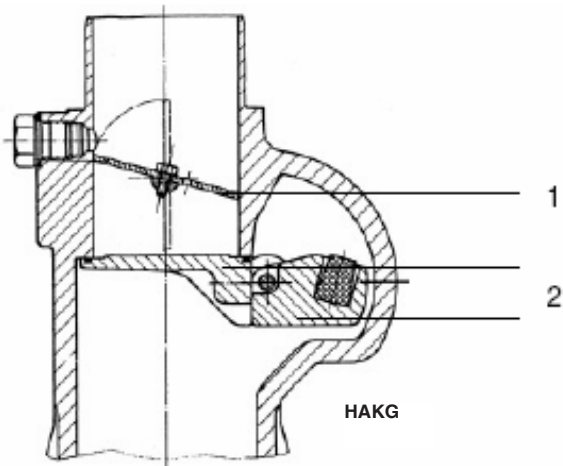

DETAIL: ROTARY DRIVE UNIT

NOTE: Schematic Diagrams Only

Blow-Down Valve

Complete Service and Dismantling

Dismantle valve completely from the compressor. Unscrew out locking screws (2) Take out piston unit (4).along with Gasket (5)

Cleaning

Work and sealing areas of the housing and its threads have to be cleaned with liquid cleaner and possible Loctite remainders have to be removed. Piston work areas have to be greased by any means. Seat and sealing areas must not be damaged

Reassembly

Insert piston unit (4) into housing. Assemble Gasket (5) cover plate and tighten the out locking screws

Function testing

Test valve function after each service or inspection at the running compressor

Inspection

Dismantle valve and check component for wear. Work and sealing areas of the housing and its threads have to be cleaned with liquid cleaner and possible Loctite remainders have to be removed. Piston work areas have to be greased by any means. Seat and sealing areas must not be damaged. Then reassemble valve as described above and test for its functioning.

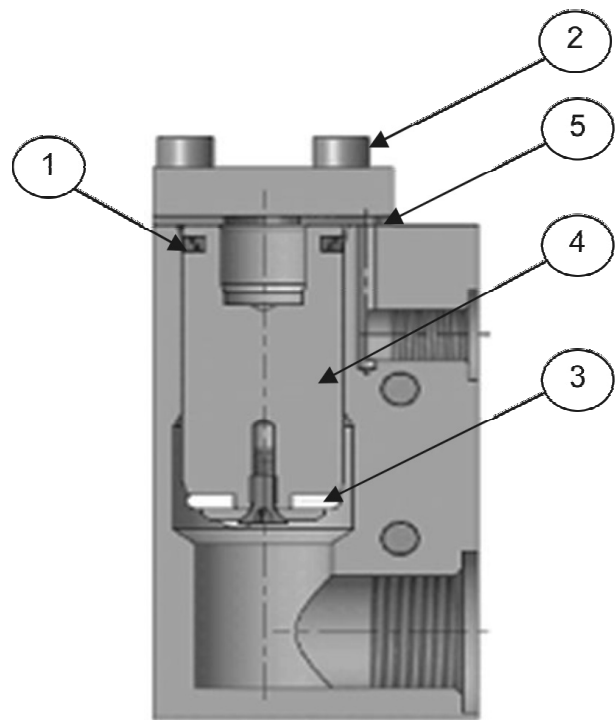

Thermal Valve

Replacing Thermal Valve Element

- * Isolate the machine from the service line, vent the air-oil sump pressure and allow the system to cool for 10 minutes
- * Release the air oil sump downstream pressure
- * Remove the snap ring (1) using pliers
- * Remove the plug (3) using M6 screw
- * Take out thermal valve element (4) from the Separator block body
- * Remove piston (5) and spring (6) from the Separator block body
- * Inspect and clean the seating area in the Separator block body
- * Replace with a new thermal valve element (4)
- * Check O-ring (2) for any damages if so replace with new O-ring (2)
- * Assemble the spring (6) in its place
- * Assemble the piston (5) over spring (6) in the same orientation as shown in below figure
- * Assemble the new thermal element (4) in its place
- * Assemble plug (3) with the O-ring (2) in its place and lock the Separator block body assembly by using snap ring (1)

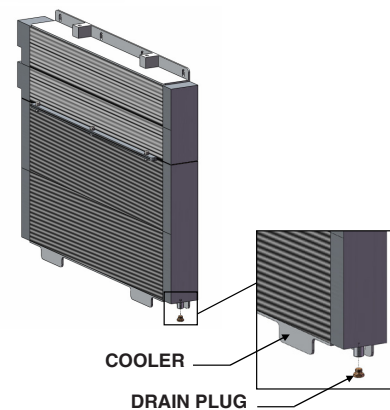
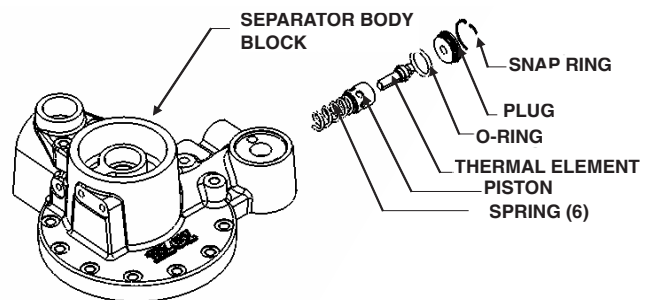

Cleaning of Internal Surfaces of oil cooler

- * For aluminum coolers, use a 5% by volume mixture of caustic soda in water. Circulate this mixture at 140 °F in the cooler for 5 hrs.



Handle toluene and isopropanol with care.
These solvents are harmful and hazardous to humans.

WARNING

Cleaning Of External Surfaces Of Oil Cooler

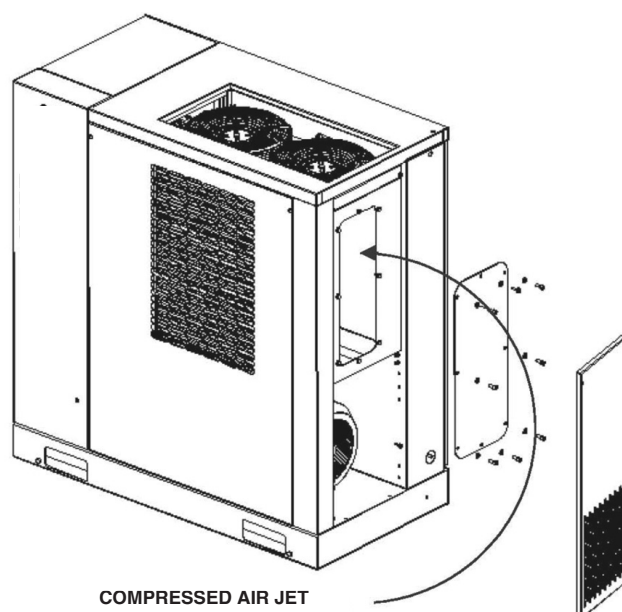

- * Isolate the machine from the service line
- * Vent the separator tank pressure before attempting maintenance
- * Open both the LH panel & cooler inspection cover
- * Use compressed air below 101.5 PSI maximum to clean the outer surface of the cooler. Supply the jet of air in opposite direction of cooling airflow direction
- * After cleaning the outer surface of the cooler properly close it with cleaning plate & LH panel

Moisture Separator and Auto Drain Valve

Dismantling

- * Isolate the machine from the service line and vent the air-oil sump pressure to atmospheric pressure
- * Disconnect the pressure sensor line
- * Manually drain the condensate by using manual discharge plug located at the bottom
- * Remove the moisture separator from the machine and clean
- * Remove the auto drain assembly from the bottom and clean.



WARNING

Moisture Separator body may be heavy. Caution should be taken when removing it from the machine

Oil Service

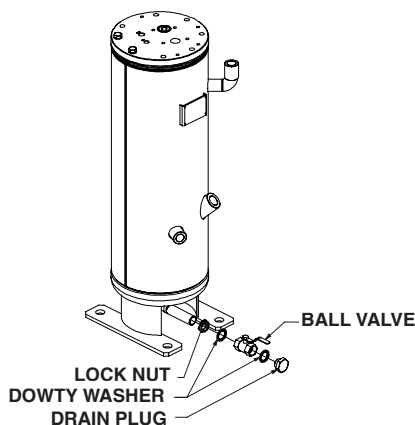

ELGI Synthetic Oil Handling Procedure

Oil Color and Quality

The new oil color is orange in color.

After the oil has been used, it is normal for the oil to change color. At any point of time, the quality of the oil can be checked by taking oil samples and sending to ELGI for analysis. Proper compressor maintenance and operation is crucial for the lubricant to function properly and last till its estimated rated oil hours.

Shelf Life and Storage

The oil product shelf life is of minimum 3 years and maximum 5 years.

Products should be kept properly sealed in the original container. Once the seal is broken, the above stated life span of the product is no longer applicable.

Products should be stored in proper storage warehouse that is away from direct sunlight and is not exposed to weather elements like rain, typhoon and snow storms. The products should also be stored away from any heat source, high humidity and moisture areas. If drums are stacked on ground level, it should be stacked horizontally with the bung openings arranged at 3 and 9 o'clock position.

ELGI recommend that once the seal is broken, all the products should be used immediately. Users are not encouraged to reuse or recycle any of these leftover fluids as there might be possibility of contamination.

ELGI will not warranty the quality of the product once the original seal is broken.

Oil Spill Handling and Disposal

Please refer to MSDS for procedures and details.

Oil Change Procedures

Synthetic compressor lubricants are specifically formulated for the lubrication of all the different types of compressors, namely, rotary screw, rotary vane and reciprocating compressors. In order to maximize the value of these synthetic lubricants, certain procedures are recommended when changing over compressors which have been operating on other type of mineral oil lubricants.

All compressor components in contact with the synthetic oils should be as clean and as free of the previously used oil is practical before changing over. Compressor Oil should not be mixed between brands and types.

Step 1: Draining

1. Drain all old oil from the unit for the normal oil change method. Drain the oil while the compressor is hot.
2. Open condensate drain valve and ensure all liquid is drained out.
3. Remove drain plug from the bottom of the separator/receiver and drain out all liquid.
4. Pump compressed air through the top valve of the separator to force out residual oil.
5. Remove pipe and drain plug from bottom of oil cooler and completely drain.
6. Disconnect all oil pipe-work which could trap oil and drain completely.

7. Elgi introduced oil sampling kit in air end oil injection line from oil filter outlet line itself from September 2014 onwards supplied units, which can be used for draining oil for lab test.

Step 2: Flushing

For flushing clean/ non-varnished machines presently using:

Mineral/ PAO oils

1. Fill the compressor with ELGI Cleaner and run the machine.
2. After 500 hours of service, drain the Cleaner. Drain all the low lying areas.
3. Refill the compressor with new compressor oil.
4. Send a sample of the compressor oil to ELGI for oil analysis after 300 hours.

Alternatively, since the compressor is clean and non-varnished, you can also use the new compressor oil as the flushing oil.

1. Fill the compressor with the new compressor oil and run the machine as normal operation.
2. Sample the lubricant and send to ELGI after 300 hours.
3. The new compressor oil may not be able to run till its stated hours in this case depending on the conditions.

Polyglycols (PAG)

1. Fill the compressor with Cleaner. Run the machine for no longer than 500 hours.
2. After 300 hours, send a sample to ELGI for analysis.
3. It may take more than 1 charge of Cleaner to properly clean the system.

For varnished machines using mineral oils, PAO or Diester, always clean the compressor with Cleaner using the following procedure:

1. Fill the compressor with Cleaner.
2. Run the Cleaner for no longer than 500 hours.
3. After 300 hours, sample the lubricant and send to ELGI for analysis.
4. It may take more than 1 charge of Cleaner to properly clean the system.
5. The Cleaner is not recommended to run longer than 500 hours.

Step 3: Resume normal operations

1. After draining and flushing, change the oil filter and oil separator.
2. Fill compressor with new compressor lubricants and resume normal operations.

Oil Sample Taking Guidelines

ELGI recommends that oil sample be taken every 2000hours or every 3 months whichever comes first.

The appropriate lubricant sampling procedure is important because it will help to ensure that the lubricant analysis data that you receive is the best representation of the lubricant within your system. Utilizing proper sampling techniques will allow for better data consistency and accuracy when determining the condition of your lubricant. Inconsistent sampling will cause the trend analysis, which is used to determine the condition of the fluid, to be inaccurate.

There are several tools that can be utilized to help the sample taking process. These procedures or tools will not be discussed, but the focus will be on the appropriate locations and timing of taking the actual lubricant sample.

All samples should be taken by trained individuals utilizing all appropriate safety practices required.

- * Use clean sample bottle kits and sampling tools.
- * Obtaining a lubricant sample while equipment is running would be ideal. If this is not possible then shut the unit down and allow cooling for 5-10 minutes.
- * The best location to take samples is past the lubricant filter. We are interested in the fluid that will actually be lubricating the equipment.
- * If the equipment does not have lubricant filters or taking samples after the lubricant filters is not possible then take the sample from the sump. Be sure to drain off all water and debris before taking the actual sample that will be sent to the laboratory. Condensation is common as the equipment cools so it is very important that all liquids are drained.

Operation and Maintenance Manual

- * Taking a sample from an actual lubricant filter is the least optimal location or the last choice.
- * All samples for a specific machine should be taken from the same sampling location and the procedure of taking the sample shall be consistent. This will allow for better trend analysis.
- * The sampling label should be completely filled out before sending the sample to the laboratory. All customer, distributor, lubricant, and equipment information needs to be entered onto the sample label in order to process the sample. Include on the sample label if there was a lubricant or filter change during sampling. It is imperative that the sample label be applied directly to the plastic sample bottle, not the cardboard canister. The mailing label can be applied to the cardboard mailing canister or if using a box to send in more than one sample, it can be attached to the outside of the box and therefore, does not need to be applied to the canister. Missing information from the sample label can result in a longer turnaround time as the laboratory will need to request the information before the sample can be processed. All the information on the information label is required for an accurate analysis.
- * Prompt delivery of the sample to the laboratory is important. Oil analysis attempts to evaluate the current condition of the oil and the equipment, so it is crucial to get the sample to the laboratory for analysis quickly after the sample is taken.
- * Follow ELGI Recommended sampling frequencies and the sampling guidelines noted on the lubricant analysis reports to determine when the next sample should be taken and sent in for analysis.

Oil Sample taking, Labeling and Shipping Procedure

- * We request that customers provide all information as to hazards related to the sample. If a hazard exists, this information should be clearly marked in the comment area on the label or on a separate of paper.
- * Fill the plastic sample bottle with as much oil as it will hold. It takes a minimum of 4 ounces (120 milliliters) of oil to perform a complete analysis.
- * Fill out the information label completely (see example below). This information is required to log the sample into our system and to ensure a complete and accurate analysis.

CUSTOMER NAME	ABC COMPANY INC		
ADDRESS	1234 ANY STREET, CITY, STATE, COUNTRY		
SERIAL NO.	L123456	SAMPLE DATE	1st Jan 2013
MACHINE MFG.	ELGI	HOURS ON OIL	500
OIL TYPE	ELGI FLUID TYPE	MACHINE HOURS	500
MODEL NO.	ANY MODEL NUMBER	CONTACT NAME	NAME OF CONTACT PERSON
COMMENTS	Any hazards that may exist in the sample		
ELGI Equipments Limited *2200 James Savage Rd. *Midland, MI 48642			

- * Attach the information label directly to the plastic sample bottle.
- * Place the plastic sample bottle, which contains the sample and the completed information label, into to cardboard mailer.
- * Record the sender’s address in the address label (see example below)

From,	ABC COMPANY INC 1234 ANY STREET CITY, STATE, COUNTRY
To	ELGI Equipments Limited Oil Services Lab2200 James Savage Road Midland, MI 48642

- * Place the completed address label around the cardboard mailer
 - o Note: the address label only needs to be attached to the cardboard mailer if shipping the sample in the cardboard canister. If additional packaging is added the address label does not need to go on the cardboard canister.
- * Ship the sample to our address on the address label

Maintenance Schedule

Sl. No.	Activity	Description	Daily	Monthly	Every 1000 hours	Every 2000 hours	Every 4000 hours	Every 8000 hours/ 1 year	Every two years	Remarks
1	Check	Hour Meter Reading	✓							
2	Check	Discharge Temperature	✓							
3	Check	Load & Unload Pressure	✓							
4	Check	Air Filter Clog Indicator	✓							
5	Check	Oil Level	✓							
6	Check	Oil Leakage	✓							
7	Check	Auto Drain Valve- Water Separator	✓							
8	Replace	Grease - Main Motor - 50Hz			2000 hours : 2 pole motor 4000 hours : 4 pole motor					Make : Lithium based high temperature ESSO UNIREX N3 or any equivalent brand of Lithium soap based Grease
		Grease - Main Motor- 60Hz			8000 hours -Up to 25 hp 4000 hours -For 30 hp to 250 hp					Make : MOBIL POLYREX EM
9	Clean	Airfilter element			Clean, If Airfilter chocking indication changes from green to red					Use moisture free compressed air at less than 36 psig(2.5 bar) for cleaning. 4 times can be cleaned maximum
10	Replace	Airfilter element					✓			Replace, If Airfilter chocking indication is in red
11	Replace	Oil Filter				✓				
12	Replace	Oil - Air Lube UT Synthetic						✓		
13	Check & Clean	Oil cooler & After cooler- Air				✓				Follow cleaning instructions.
14	Check & Clean	Oil cooler & After cooler- Water Cooled version						✓		Depends on water quality. Follow cleaning instructions.
15	Check	Intake Valve Kit						✓		
16	Check	Minimum Pressure Valve Kit						✓		
17	Check	Blow Down Valve Kit						✓		
18	Check & Replace	Solenoid Valve						✓		
19	Check	Safety Valve						✓		
20	Calibrate	Switches, Gauges & Sensors						✓	✓	8000 hours or 2 years which ever is earlier.
21	Replace	Separator Element & AOS Gasket						✓		
22	Check	Electrical connections						✓		
23	Clean	Tank						✓		
24	Replace	Pre Filter				✓				
25	Replace	Drive Coupling Element						✓		
26	Check	Water Leakage	✓							Applicable only for Water Cooled Compressors
27	Check & Clean	Steel Tube- Oil Return Line					✓			
		Nylon Tube- Oil Return Line				✓				
28	Replace	Steel Tube- Oil Return Line						✓		
		Nylon Tube- Oil Return Line					✓			
29	Check & Replace	Nylon Tube- Others						✓		
30	Check & Replace	Anti Vibration Mounts							✓	
31	Check	Oil sampling				✓				For oil condition - Lab Analysis
32	Clean	Pre-filter & Moisture drain			✓					

Precautions

A. If the compressor kept idle for more than 30 Days

1. Close the Main Air outlet Valve.
2. Drain the Water from the Compressor System.
3. Close the Inlet and Outlet water valve. (Applicable only for Water Cooled compressors)

B. If the Compressor kept idle for more than 6 months and above

Apart from above points other precautions are

1. Rotate the compressor shaft once in 7 days and ensure free rotation of shaft.

The above life time guidelines applicable only to standard operating and regular maintenance conditions recommended in product manual. In the event of changes in the conditions, consult ELGI.

Decommissioning, Dismantling and Putting Out of Service

Waste Disposal

- * Use of the compressor generates substantial waste. The residues from industrial, agricultural, crafts, commercial and service activities must be treated as waste, which needs to be disposed of properly. Deteriorated or obsolete machines are also classified as waste.
- * Special attention must be paid to active carbon filters as they cannot be included in urban waste: observe the waste disposal laws in force where the compressor is used.
- * Please note that it is compulsory to record loading/unloading of exhausted oils, obsolete machines and toxic-harmful wastes that derive from heavy/light industry processes.
- * It is especially important that exhausted oils be disposed of in compliance with the laws in the country of use.

Dismantling the compressor

- * Dismantle the compressor in accordance with all the precautions imposed by the laws in force in the country of use.
- * Disconnect the compressor from the electrical system.
- * Eliminate any interfaces the compressor may have with other machines, making sure that interfaces between remaining machines are unaffected.
- * Empty the tank containing the lubricating oil and store in compliance with the laws in force.
- * Proceed with disassembly of the individual compressor components and group them together according to the materials they are made of: the compressor mainly consists of steel, stainless steel, cast iron, aluminum and plastic parts.
- * Then scrap the machine in compliance with the laws in force of the country of use.

Decommissioning the compressor

- * Remove the foundation laid for the compressor initially. Unplug the Power cable entry to the compressor and then drain the oil from the Cooler and Tank and dispose it properly.
- * Make sure all the compressed air is vented out through ball valve and safety devices provided in the compressor.
- * Ensure that all the external supply lines have been properly disconnected from the compressor before Decommissioning.

Disposal of Consumables and Replaced Parts

The moisture condensate separated from compressed air contains oil particles. Disposal of the condensate and filter elements is to be done in accordance with the pollution control norms prevailing at the time of compressor installation or use

Parts of the compressor that are replaced have metal and rubber components. These may be recycled and disposed of according to local pollution control regulations.

- * Drained off compressor oil and moisture drain to be disposed according to environmental regulations.
- * Dispose all other parts and machine in accordance with local environmental regulations.



The compressor does not give warnings during short operating times. If it is operated below the dew point and moisture condensate may mix with the oil. This will reduce the lubricating qualities of the oil and lead to damage of the compressor

Troubleshooting

Problem: Machine Not Starting

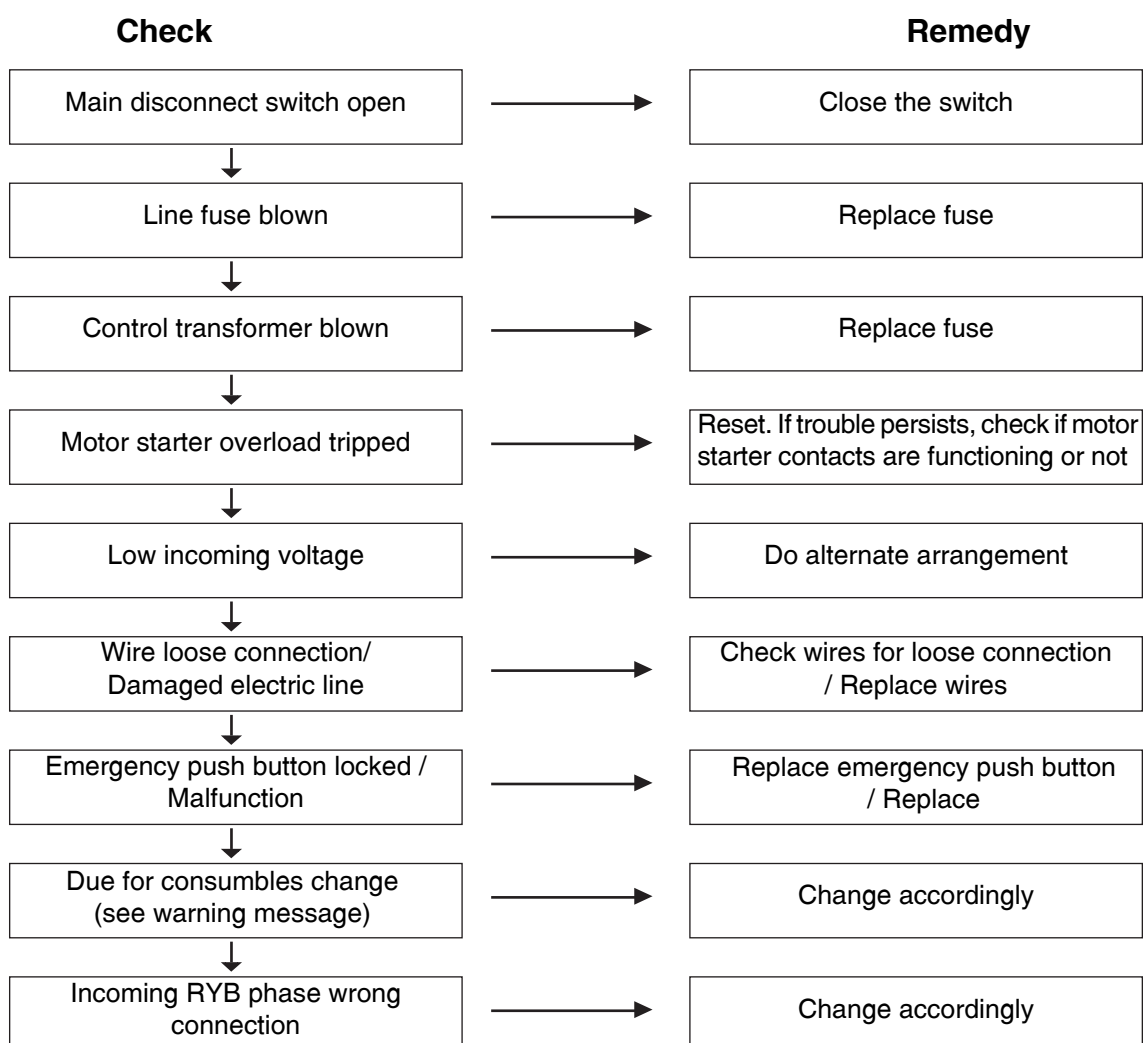

Problem: Machine Status Down With Air Demand Present

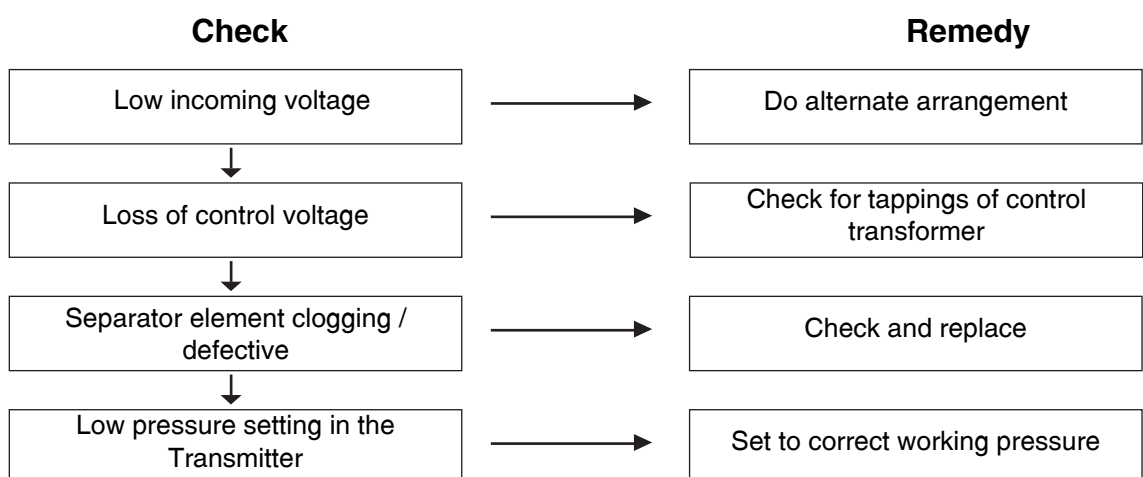

Troubleshooting

Problem : High Discharge Temperature Trip

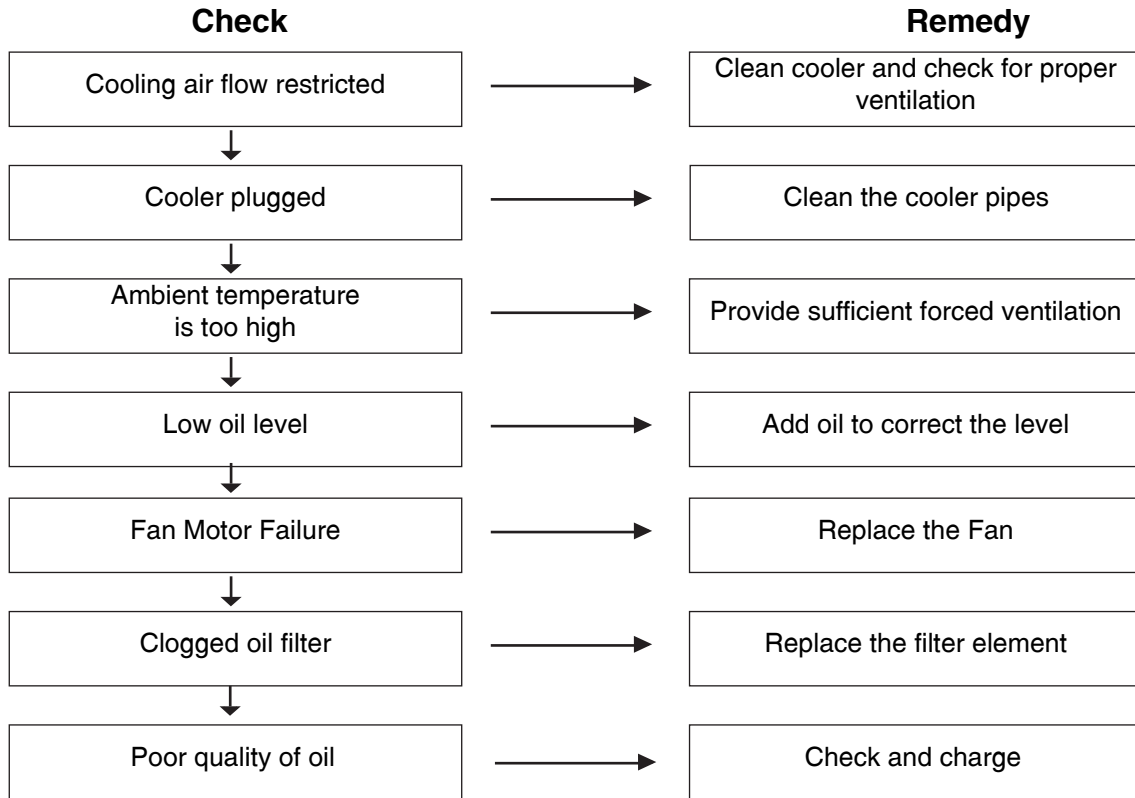

Troubleshooting

Problem: Excessive Oil In Service Line / Consumption

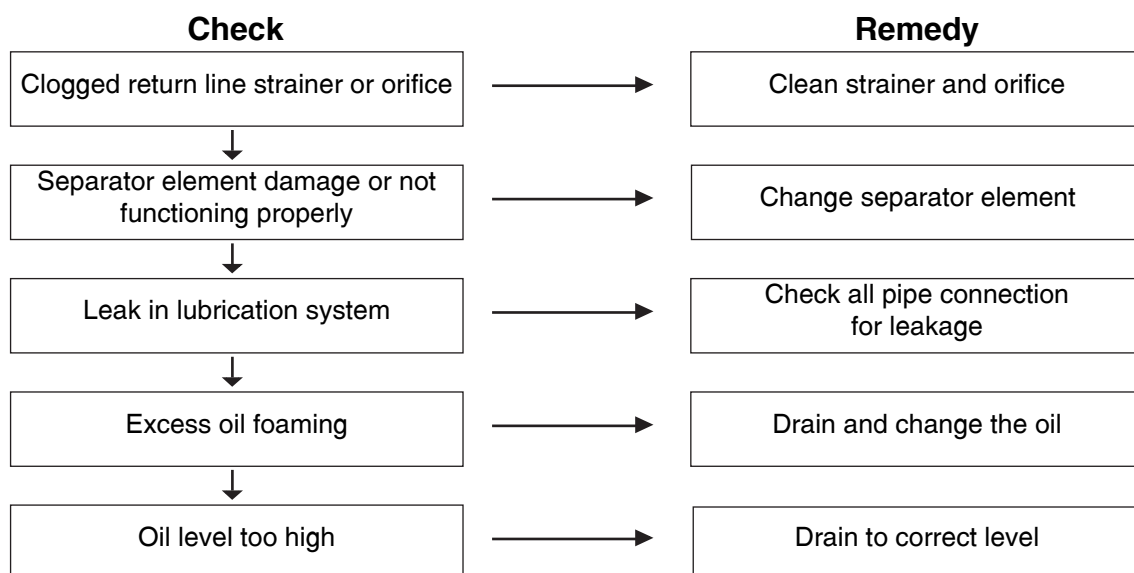

Problem: Oil leaking through suction side when the unit is switched off

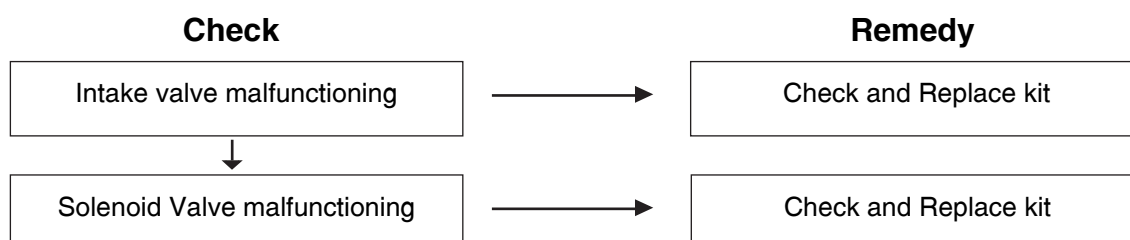

Problem: Pressure relief valve opens

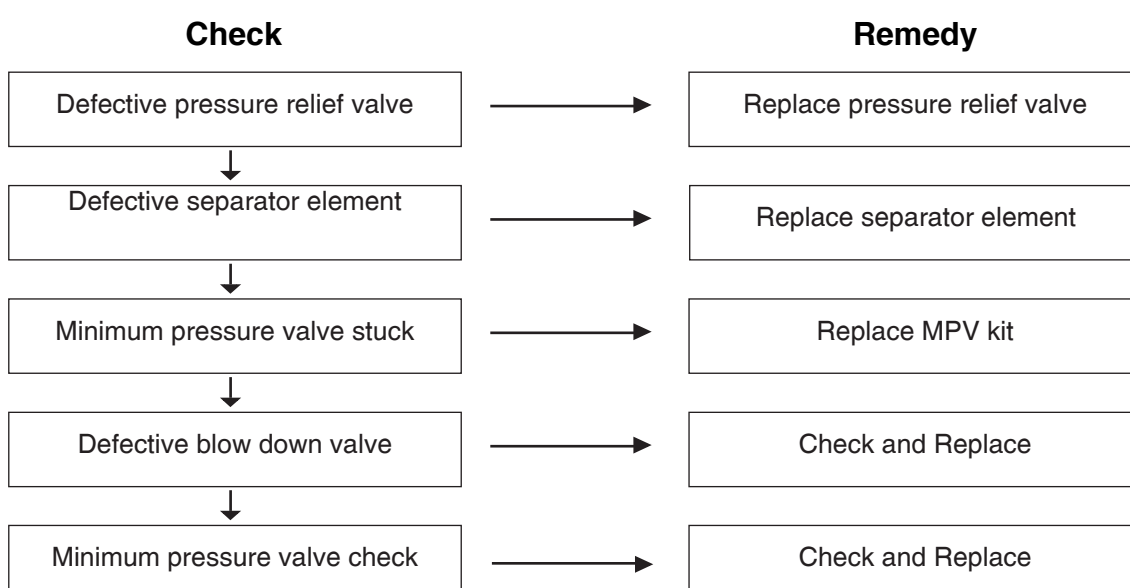

Troubleshooting

Problem : Machine not building up full discharge pressure

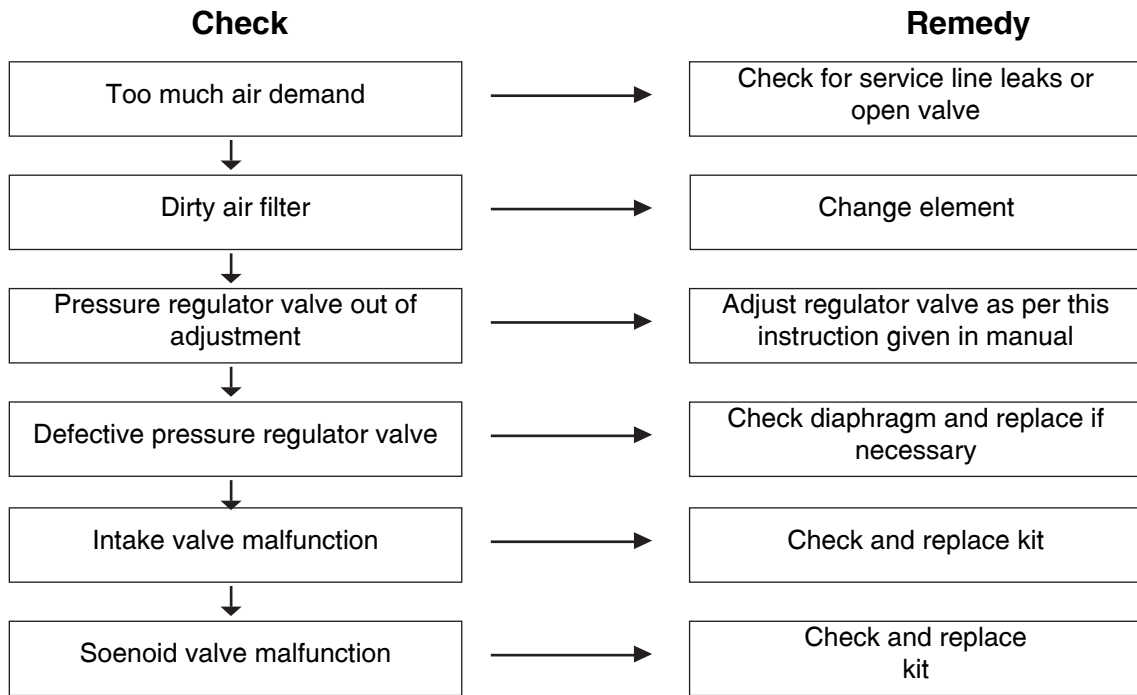

Problem: Excessive operating pressure

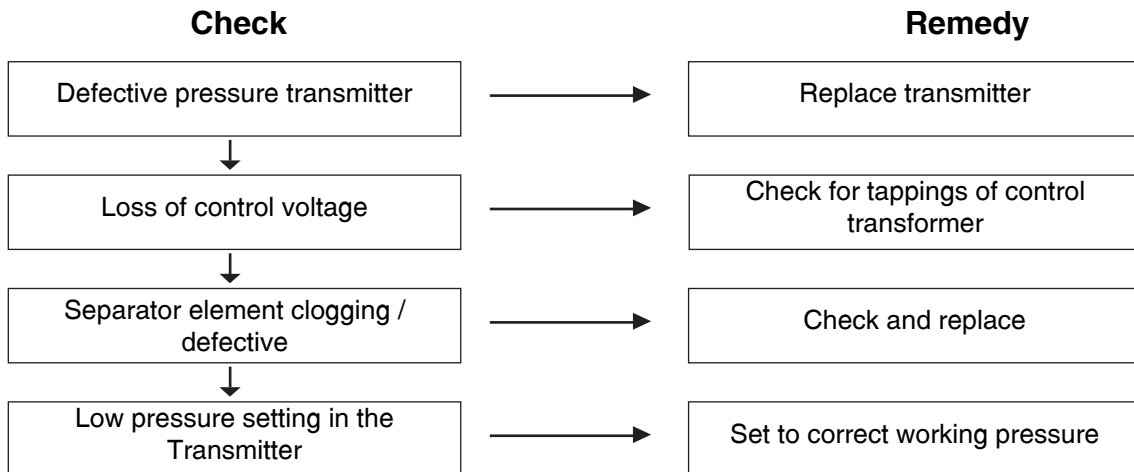

Conversion Tables

Description	From	To	Multiply by
Length (l)	Inches	Millimetres	25.4
	Metres	Inches	39.37
	Feet	Millimetres	304.8
	Metres	Feet	3.281
	Inches	Thou	1000
	Millimetres	Micrometres	1000
Area (A)	Square metres	Square feet	10.765
	Square feet	Square inches	144
	Square inches	Square Millimetres	645.16
Volume (V)	Cubic metres	Cubic feet	35.315
	Cubic feet	Cubic inches	1728
	Cubic metres	Litres	1000
	Cubic feet	Litres	28.32
	US gallons (liq)	Litres	3.785
	Imperial gallons (liq)	Litres	4.546
Volumetric flow (Q)	Cubic feet per minute (cfm)	Cubic metres per hour (m ³ /h)	1.6988
	Cubic feet per minute (cfm)	lpm	28.32
	Cubic metres per hour (m ³ /h)	lpm	16.667
	Cubic metres per minute (m ³ /min)	Litres	28.32
	US gallons (liq)	Litres	3.785
	Imperial gallons (liq)	Litres	4.546
Mass (M)	Kilograms	Pounds	2.205
	Kilograms	Grams	1000
	Kilograms	Ounces	35.27
Pressure (P)	Kgf/cm ² g	Pounds/sq.inch(PSI g)	14.223
	PSI g	Pascals (Pa)	6895
	Bar g	kgf/cm ² g	1.0197
	Bar g	PSI g	14.503
	PSI g	kgf/cm ² g	0.0703
Temperature (T)	Degrees Celsius (C)	Degrees Fahrenheit (F)	F= 9C/5 + 32
	Degrees Celsius (C)	Degrees Kelvin (K)	F= C+273.15
	Degrees Fahrenheit (F)	Degrees Rankine (R)	R= F + 460
Heat (Q), Work (W), Energy (E)	Ft-lbf	Joules	1.35582
	Ft-lbf	Btu	0.001285
	Keal	kgf m	426.9
	Joules	Calories	0.2388
	Btu/h	Calories/h	252
	Kilowatts	Btu/h	3411
Power (P)	Metric horsepower	Kilowatts	0.7355
	Imperial horsepower	Kilowatts	0.7457

Torque Values

The tightening torque values for bolts and screws used in Elgi compressors are provided in this section for reference. The tolerance for the torque values is ± 10 percent

Metric hexagonal head bolts and screws

Thread size	Tightening Torque in N.m	Tightening Torque in ft-lbs
M4	3	2.2
M5	6	4.4
M6	10	7.4
M8	16	11.8
M10	24	17.7
M12	40	29.5
M16	120	88.5
M20	160	118.0
M22	351	258.9
M24	447	329.7
M27	654	482.4
M30	888	655.0
M33	1208	891.0
M36	1552	1144.7
M39	2008	1481.0
M42	2481	1829.9

BSP threads

Thread size	Tightening Torque in N.m	Tightening Torque in ft-lbs
1/4 "	10	7.4
1/2 "	40	29.5
3/4 "	70	51.6
1 "	70	51.6
1 1/4 "	120	88.5
1 1/2 "	120	88.5

UNF threads

Thread size	Tightening Torque in N.m	Tightening Torque in ft-lbs
9/16 "	34	25.1
7/8 "	40	29.5

Glossary

A	Pages	M	Pages
About Elgi	7	Machine Identification and Sales Record	4
Air Pipelines	16	Message from the Managing Director	6
Airend	20	Motors	20
Air-Oil Separator Tank	20	Minimum Pressure Valve	31
Air Intake System	22	Maintenance	27
Air Filter	30	Maintenance Instructions	40
B			
Blow Down Valve	33		
C			
Commissioning Process	12	O	
Compressor Location	13	Operating Precautions	8
Cooling and Lubrication System	23	Oil Fill Procedure	18
Conversion Table	46	Operation	25
D			
Definitions and Symbols	5	Oil Filter	27
Dos and Don'ts	9	Oil Change Procedure	29
Disposal of Packing	20	Oil Cooler	35
Drive System	22	P	
Discharge System	23	Pre- Filter	29
Drive Coupling	30	R	
Decommissioning, Dismantling and Putting Out of Service	41	Receivers for Compressed Air Systems	17
Disposable of Consumables and Replaced Parts	41	S	
E			
Electricals	16	Symbols	5
Extended Storage	20	Safety	8
Electrical Systems and Controls	22,24	Separator Element	28
F			
Foundation	15	Service Log Book	48
Functional Description	21	T	
G			
EG Series and Salient Features	6	Technical Specification	10,11
H			
Handling the Compressor	12	Thermal Valve	34
I			
Installation	12	Trouble Shooting	42
Installation- GA Diagram	14	Torque Values	47
Intake Valve	33	U	
		Using the Manual	5
		Unpacking	12
		V	
		Ventilation and Exhausting Hot Air	15

Neuron II Manual

Version : 1.8 April 2015

INDEX

	Abbreviations Used	5
1.0	1. Technical Specification	6
2.0	2. Installation Instruction	8
	2.1. Equipment's Safety	8
	2.1.1. Static Discharge Warning	8
	2.1.2. Assembly	8
	2.1.3. Do not expose to direct sunlight	9
	2.1.4. Must be protected from rain	9
	2.1.5. Do not install equipment on structures subject to continuous vibration	9
	2.1.6. Electrical Connection	9
	2.1.7. Power Supply	9
	2.2. General Instruction	9
3.0	3. Front View :	10
	3.1. Terminal Connection	11
4.0	4. Neuron-2 Salient Features	11
5.0	5. Input Output Description	13
6.0	6. Main Screen	14
	6.1. Important Machine Settings for Users:	16
7.0	7. Menu Structure	18
	7.1 View	18
	7.1.1 Operator	19
	7.1.2 Fault Report	19
	7.1.3 Day Report	20
	7.1.4 Service Time	20
	7.1.5 Cumulative Time	20
	7.1.6 VFD	20
	7.2 Operator	20
	7.2.2 Schedule	22
	7.2.3 Maintenance	22
	7.2.4 Language	22
	7.2.5 VFD Control	22
	7.2.6 Change Password	24
	7.3 Service	24
	7.3.1 Calibration (Offset)	24
	7.3.2 Relay	25
	7.3.3 Temperature	25
	7.3.4 Maintenance	25
	7.3.5 Clock	25
	7.3.6 Self-Test	25
	7.3.7 Change Password	26
	7.3.8 Digital Input	26
	7.3.9 Dryer Input	26
	7.4 Factory Menu	26
	7.4.1 Machine	27
	7.4.2. Dryer	27

	7.4.3 Change Password	28
	7.5 Customer care	28
	7.6 Admin	28
8.0	8. Data Interface	29
	8.1 Analog output	29
	8.2 DCS Port	29
9.0	9. Construction	29
	9.1 Dimension Drawing	29
10.0	10. Example – scheduler setting	30
11.0	11. Modbus Details	32
12.0	12. Revision Details	32

Abbreviations Used

Dis. Pressure	Discharge Pressure
Dis. Temperature	Discharge Temperature
DPAF	Differential Pressure Air Filter
DPOF	Differential Pressure Oil Filter
HSP	High sump pressure
Temp	Temperature
AF	Air Filter
OF	Oil Filter
Min	Minimum
Max	Maximum
VFD	Variable Frequency Drive
AO	Analog Output
UL	Unload
En	Enable
Dis	Disable
L	Load
St	Stop
F	Fault
R	Run
Sby	Standby
STC	Start Count
LDC	Load Count
HH	Hour
MM	Minute
Ph Fail	Phase Failure
Pr	Pressure
Tr	Temperature

1.0 Product Specification

Identification	:	ELGI Neuron II
Definition	:	WWWPre-programmed logic controller
Function	:	Compressor control system & I/O Monitoring
Part number	:	00897701N
Software	:	Version 1.1PK3 - Programmable thru ISP Port
Supported Protocol	:	MODBUS RTU (RS485 Serial Communication)
Rated Voltage	:	24VAC \pm 15%, 50 Hz
Rated Current	:	500mA @ 24VAC
Power Consumption	:	13W (Max)
Ride through	:	20ms
Flash memory	:	256Kbytes, (Usage: Program storage)
NVRAM	:	56bytes (Usage: Day Hour Counter, Cumulative Counters, and Service Remaining Hours and Dryer off time)
Graphic Display	:	128X64 White Backlight Graphical LCD
Backlight	:	Adjustable, factory default: factory default: 8.95V, tolerance +/- 0.5V
Keypad	:	9 Keys (Usage: menu keys, start, stop & reset) 11 LED (status, warnings and fault indication)
Language	:	English, French, Portuguese, Italian and Spanish
Enclosure Material	:	Mild Steel, Powder Coated
Dimensions	:	260 X 145 X 75 mm
Mounting	:	Panel mount using 6 screws
Mating Connectors	:	Phoenix-MSTB 2,5/xx-ST-5,08 / Wurth-691 351 500 0xx
Protection Class	:	IP65 for front only
Operating temp	:	0 to 45°C
Storage temp	:	-10 to 70°C
Relative Humidity	:	<95% @ 40°C without condensation.
Altitude	:	xx
Certification	:	ETL, CE
Overvoltage category	:	CLASS III

For Technical support/assistance contact ELGI Customer Care

Toll Free: (web site name only available in menu)

E-mail: ccs@elgi.com

Digital Inputs:

Number of Channel	:	8
Input Voltage	:	24VDC
Input Current	:	2.4 mA
Input Resistance	:	10000 ohm
Switching Threshold Low	:	120µs
Switching Threshold High	:	90µs
Isolation	:	optically isolated 2500Vrms

Usage

Emergency Stop, Motor overload, Cooler over Load, DPAF or Remote Load/Unload, DPOF, Motor Reverse Rotation, Remote on/off & Dryer Input (if enabled).

Digital outputs

Number of Channel	:	8
Output Type	:	Electro Mechanical Relay
Rated Voltage	:	24VDC / 230VAC
Rated Current	:	1.8A @ 230VAC / 1.8A @ 24VDC
Leakage Current	:	0.06 mA in Output Off Condition
Switching Delay Off to ON	:	10 ms
Switching Delay ON to Off	:	5 ms
Max. Withstands impulse	:	4500V

Usage

6 Pre-programmed (Main, Star, Delta, Load, ADV, Fan Motor)

2 by default Programmed for Trip and Warn but Programmable for Warn, Load, Service, Standby, Trip, Remote & Ready. (2nd Programmable Relay is fixed for dryer, if enabled)

Analog inputs:

Number of Channel	:	4
-------------------	---	---

2 x 4-20mA inputs

Range	:	0 to 16 bar/psi
Resolution	:	0.1bar/psi
Accuracy	:	±0.2bar/psi
Usage	:	Discharge Pressure and Sump Pressure

1 x KTY10

Range	:	-10 to 150 °C
Resolution	:	1 °C
Accuracy	:	±5 °C
Usage	:	Discharge Temperature

1 x PT1000

Range	:	-10 to 150°C
Resolution	:	1°C
Accuracy	:	±2°C
Usage	:	Ambient or Dryer Temperature, Software Selectable

Analog output:

Number of Channel	:	2
Range	:	1 to 5VDC
Resolution	:	0.1V
Accuracy	:	+/-0.1V
Usage	:	Discharge Pressure and Discharge Temperature

Communication Ports

Port1	:	RS485, MODBUS RTU (for DCS interface)
Port2	:	RS485, MODBUS RTU (for VFD Parameter Reading)
Port3 & Port4	:	Not used, Reserved for future use



WARNING!

2. Installation Instruction

2.1. Equipment's Safety

The device was checked before delivery according the prescribed tests of the inspection scheme. In order to maintain this status through shipment and secure a safe operation, the user must consider the notes and warning notes, which are given in these safety notes and the instruction manual. The device may be operated by only trained persons. Maintenance and repair may be executed only by trained, technical persons, who are familiar with the associated dangers. The device can be operated without impairment of its security within the certified environment condition.

2.1.1. Static Discharge Warning



This equipment is sensitive to electrostatic discharge, which can cause internal damage and affect normal operation. Follow these guidelines when you handle this equipment:

- * Touch a grounded object to discharge potential static.
- * Wear an approved grounding wrist-strap.
- * Do not touch connectors or pins on component boards.
- * Do not touch circuit components inside the equipment.
- * Store the equipment in appropriate static-safe packaging when not in use.

2.1.2. Assembly

The place of assembly has to correspond to the class of protection. The ambient temperature in the Installation position may

not exceed the admissible temperature for the nominal use, specified in the data sheet. Not to use in wet condition. The devices may be installed only outside of explosion hazardous areas!

2.1.3. Do not expose to direct sunlight

Since the electronic circuits must not be subjected to uncontrolled temperatures. Place the cabinet in shade.

2.1.4. Must be protected from rain

Partial tightening of the screws or doors would allow water to enter the enclosure and cause irreparable damage to the circuitry. Provide Canopy to avoid such damages.

2.1.5. Do not install equipment on structures subject to continuous vibration

Since partial tightening of the wires or components in the cabinet would disconnect during vibrations and cause irreparable damage to the circuitry.

2.1.6. Electrical Connection

The external connections are to be carried out according to the respective national rules.

Switch off the device before carrying out any wiring work.

Do not connect or disconnect any wire when device is powered on.

2.1.7. Power Supply

It is to be guaranteed that supply voltage corresponds with the specification on the type sign.

If the device is switched with other devices and/or mechanisms, then the effects are to be considered before switching and appropriate precautions have to be taken. Do not connect welding or such high noise sources to the same line of controller supply.

2.2. General Instruction

The following procedures and instructions should be followed closely to avoid damage to the control panel and its associated equipment. Reliability of the system depends upon proper installation and maintenance.

The device is to be examined for damages by inappropriate handling with feed and Storage. If the device indicates damage, so that safe operation is not possible, then the device may be taken not in operation.

Carefully unpack the system. Open door and Inspect the cabinet, door, printed circuit board and other components for the possibility of shipping damage. It is recommended that the cabinet stored in a clean dry area until mounting takes place.

The signal cables and power cable should be separately routed.

The Protective Earth connection in the panel must be connected to Field Earth only.

3. Front view

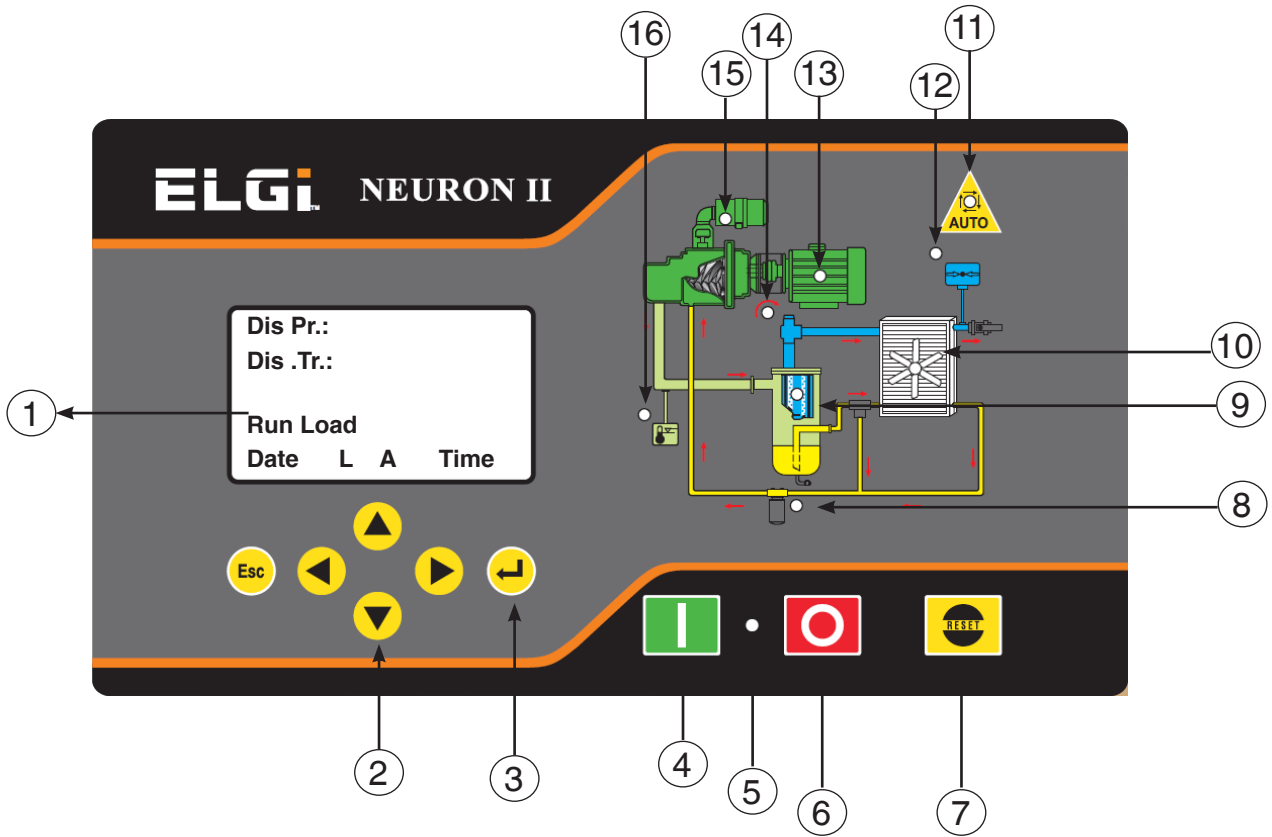

1	128x64 Graphical Display	9	Air Oil Separator change indication LED
2	Navigation Keys	10	Cooler Fault LED
3	Enter Key	11	Auto Mode Enabled indication LED
4	Start key	12	High Pressure fault LED
5	LED (Green – Start , Red – Stop/Fault)	13	Main Motor fault LED
6	Stop Key	14	Reverse Rotation fault LED
7	Reset Key	15	Air Filter Change indication LED
8	Oil Filter change indication LED	16	High Discharge temperature fault LED

3.1 Terminal Connection

- X01 – Power Supply 24VAC, Earth, Neutral
- X02 – Relay Outputs (5 Ports)
- X03 – Relay Outputs (3 Ports)
- X04 – Digital Inputs (8 Ports)
- X05 – Analog Inputs (4 Ports)
- X06 – Analog Outputs (2 Ports)
- X07 – Communication Ports (4 Ports)

180.00x65.00mm NEW ONES dated 06.08.2014

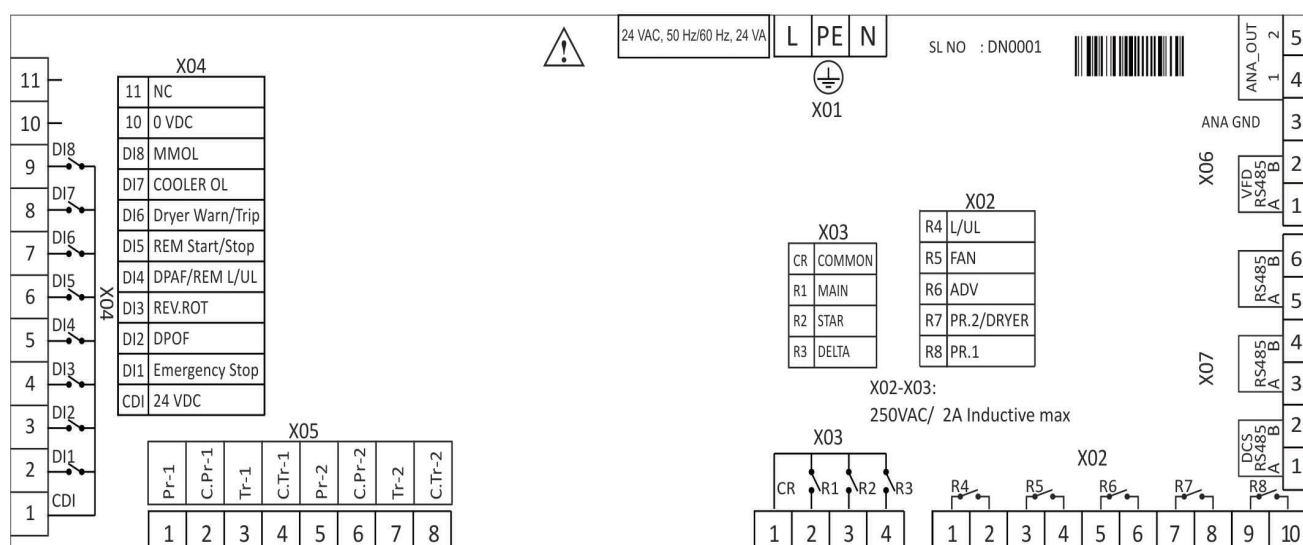

4. Neuron-2 Salient Features

4.1. Home Screen Display

- * Easy User Interface 8 line Graphical Display and intuitive menu navigation keys

4.2. Records (View -> Day report and Fault report)

- * 30 day reports (Load hours, Unload hours, Run hours, Stop hours, Fault hours, Standby hours, Start Count, Load Count)
- * 99 fault Reports
- * Faults with Date and time stamp, Status of the machine at the time of fault etc.

4.3. Remote Function (both from MODBUS as well as Digital Input)

- * Remote Loading and Unloading
- * Remote Start and Stop

4.4. Lead and Lag – Pressure schedule (Operator -> Schedule)

- * 32 Pressure Program (one schedule should be in Sunday (first day of the week) 00:00 Hrs)
- * Important parameters to customise – Day, On Time, OFF Time, Load Pr, Unload Pr
- * Refer Page# 32 for detailed example

4.5. Other Interfaces and Communication

- * VFD interface through MODBUS
- * PC interface through MODBUS - To download Reports and Setting parameters

- * 70 + Modbus Parameters for DCS controls
- * Dryer Integration
- * Power OFF 120 Sec Delay
- * High, Low Dew Point warnings

4.6. Safeguard

- * The ‘Smart Logic’ of NEURON II automatically decides the start delay required to ensure minimum wait time between successive starts of the compressor and dryer thereby increasing their lifetime.
- * Start Inhibit till sump pressure is within safe limits to enhance the life of the compressor
- * Low Voltage & Short time Power Interrupts detection to enhance the life of the contactors
- * Low temperature start inhibit to avoid start-up overloads

4.7 Mimic LED for fault indications

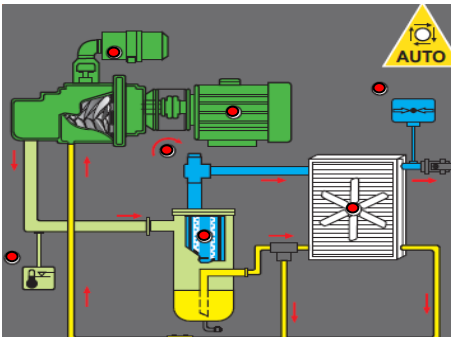

LED	Description
Auto	To indicate the machine is in automatic on/off mode. This LED glows in Amber Colour on the below conditions 1. When Pressure Schedule is enabled (or) 2. When Auto Restart is enabled
Air Oil Separator	Glows in Amber colour when 1. Air Oil Separator Service is due based on service hours
Main Motor Overload	Glows in Red when the main motor overload Digital Input is Open.
Reverse Rotation	Glows in Red when the Reverse Rotation Digital Input is Closed.
Cooler O/L	Glows in Red when the cooler Digital Input is Open
Pressure	Glows in Red when 1. Analog Pressure Input is Open (Probe Failure) 2. Dis. Pressure is higher than set HSP 3. Sump. Pressure is higher than set HSP
Temperature	Glows in Red when the 1. Analog Temperature Input is Open (Probe Failure) 2. Dis. Temperature is higher than set Trip temp.
Differential Pressure Oil Filter (DPOF)	Glows in Amber when the 1. DPOF Digital Input is Open & DPOF is enabled 2. Oil Filter Service is due
Differential Pressure Air Filter	Glows in Amber when the 1. DPAF Digital Input is Open & DPAF is enabled 2. Air Filter Service is due
Start & Stop	1. Glows in Red when machine is stopped / idle 2. Glows in Green when machine is running

5.0 Input Output Description

5.1 - X01: Power supply

Pin	Function	Id	Active state
1	24V AC Phase	24 VAC P	-
2	Earth	Earth	-
3	24V AC Neutral	24 VAC N	-

5.2 - X02: Relays

Pin	Function	Id	Active state
1	Common - Load Relay	Common	
2	Load Relay	Load / Unload	Load when Energized
3	Common - Fan Relay	Common	
4	Fan Relay**	Fan	FAN ON when Energized
5	Common - Auto Drain Valve Relay	Common	
6	Auto Drain Valve Relay	ADV	ADV ON when Energized
7	Common – Dryer Relay	Common	
8	Dryer Relay**	Dryer / Pr2	Energized
9	Common - Programmable Relay	Common	
10	Programmable Relay	Pr1	Energized

** Not all the compressors are enabled with these functions by default. Refer the Electrical Drawing for more details.

5.3 - X03: Main Motor Relays

Pin	Function	Id	Active state
1	Common for Main, Star and Delta contactors	Common	-
2	Main Contactor	Main	Energized
3	Star Contactor	Star	Energized
4	Delta Contactor	Delta	Energized

5.4 - X04: Digital inputs

Pin	Function	Id	Active state
1	Digital Inputs Common – 24VDC	24VDC	-
2	Emergency Stop	Emergency	Fault if open
3	Differential Pressure Oil Filter	DPOF	Warn if open
4	Reverse Rotation	Rev. Rot	Fault if closed
5	DPAF/REM Load and Unload	DPAF/REM L/UL	Warn or unload if open
6	Remote Start Stop Control	Remote Start /Stop	Stop if open
7	Dryer Warn/Trip	Dryer Warn/Trip	Warn/Fault if open
8	Cooler Motor Overload	Cooler OL	Fault if open
9	Main Motor Overload	MMOL	Fault if open
10	0V DC	0V DC	-
11	No Connection	NC	-

5.5 - X05: Analog Inputs

Pin	Function	Id	Type	Range
1	Discharge pressure	Pr-1	4-20 mA	0 to 16 bar / psi
2	15 to 24VDC	C.Pr-1		
3	Common Dis.Temp	C.Tr-1	KTY10	-10 to 150 °C
4	Discharge temperature	Tr-1		
5	Sump Pressure	Pr-2	4-20 mA	0 to 16 bar / psi
6	15 to 24VDC	C.Pr-2		
7	Common Dryer/ Ambient Temp.	C.Tr-2	PT 1000	-10 to 150 °C
8	Dryer	Tr-2		

** Not all the compressors are enabled with Sump pressure functions by default. Refer the Electrical Drawing for more details.

5.6 - X06: Analog outputs and VFD

Pin	Function	Id	Type	Protocol / Range
1	VFD Interface**	VFD A	RS485 A	Modbus RTU Protocol
2	VFD Interface**	VFD B	RS485 B	
3	Supply Ground For 5V	0VDC	-	-
4	Dis. Pressure Output (0 to 16 bar/psi)	AO1	Voltage	1 to 5v
5	Dis.Temperature (-10 to 150 Deg C/Deg F)	AO2	Voltage	1 to 5v

** Not all the compressors are enabled with VFD functions by default. Refer the Electrical Drawing for more details.

5.7 - X07: Communication

Pin	Function	Id	Type	Protocol
1	DCS Interface	DCS A	RS485 A	Modbus RTU Protocol
2	DCS Interface	DCS B	RS485 B	
3	Reserved	A	RS485 A	
4	Reserved	B	RS485 B	
5	Reserved	A	RS485 A	
6	Reserved	B	RS485 B	

6.0 Main Screen

- * Discharge Pressure at 0.1bar/psi Resolution
- * Oil Temperature at 1° C Resolution
- * Trip or Machine Status like Run, Load, Unload, Standby etc.,
- * Warning Messages
- * Date and Time with Mode Information
- * VFD Speed % on screen if VFD mode is enabled

Dis.Pr :	0.0bar/psi
Dis.Tr :	25°C
Speed: %	
Faults/Machine Status	
Warning Messages	
01/12 PS L A	14:20:10

(**Mode Info:** PS – Pressure Schedule Enabled, UL – Unload Mode Enabled, L – Local, R – Remote, D – DCS, A – Auto Restart ON, M – Manual (Auto Restart OFF). For more details refer Machine settings in Operator Menu)

- * With Right, Left, Up and Down scroll
You can view ...
- * Pressure setting parameters
- * Sump Pressure at 0.1 Resolution
- * Dew Point temperature
- * Current Day report

► **“RIGHT” - Live Analog Values**

1. Live Differential Pressure (Displays only if Sump Pressure enabled)
2. Live Sump Pressure (Displays only if Sump Pressure enabled)
3. Live Pt1000 Temperature (Displays only if Dryer ON enabled)

▲ **“UP” – Set Analog Values**

1. Set Load Pressure
2. Set Unload Pressure
3. Set Start Sump Pressure (Displays only if Sump Pressure enabled)
4. Max Differential Pressure (Displays only if Sump Pressure enabled)

▼ **“DOWN” – Today Report**

1. Load and Stop Hours
2. Unload and Fault Hours
3. Run and Standby Hours
4. Start Count and Load Count

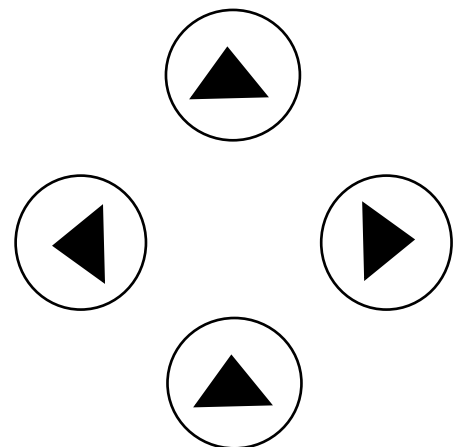

Message 1 - Compressor Status message

Status	Description
Ready	Ready for Start
Star	Motor Running in Star
Run	Motor Running in Delta
Run Load	Compressor in Load
Run Unload	Compressor in Unload
Stop Busy	Stop Sequence in Progress
Emergency Stop	Emergency Stop Push Switch is ON
Start Inhibit xx.x	During the Start, if the Sump Pressure is higher than the set start sump pressure value, you will see this message. XX.X denotes the live sump pressure value. The Compressor Starts only if the Sump Pressure value goes below the set value.
Temperature Inhibit \pm XX	During the Start, if the Discharge temperature is higher than the set inhibit temperature value, you will see this message. \pm XX denotes the live Discharge Temperature Value. The Compressor Starts only if the Discharge Temperature Value goes above the set value.
Start Inhibit "seconds"	If Sump Pressure is Not used (Disabled) then the controller will ensure minimum 60 seconds delay between the stop and the start. Count stops if "STOP" key is pressed
Auto Restart "seconds"	If Compressor is in Auto Mode, The controller will ensure minimum delay (user set, e.g. 90 sec) between stop and start. Count stops if "STOP" key is pressed
Start ack wait...	This message is displayed after a fault is cleared and waiting for user acknowledgment By pressing "RESET" key user can acknowledge.
Standby	Compressor in Standby

Message 2 - Compressor Fault messages

Fault	Description
Pr. Probe Failure	Discharge Pressure Sensor Probe Failure
Tr. Probe Failure	Temperature Sensor Probe Failure
Sump Pr. Probe Failure	Sump Pressure Sensor Probe Failure
HSP (AS)	Case 1: Sump Pressure is enabled If Sump Pressure exceeds the set high sump pressure value.
HSP (AD)	If Discharge Pressure exceeds the set high sump pressure value.
Cooler	If the Cooler Digital Input Opens due to Cooler fault
Main Motor Overload / VFD Error	IF the MMOL Digital Input Opens due to Main Motor Over Load. VFD Error if VFD control is enabled
Rev Rot / Ph Fail	If the Rev Rot Input Closes when Motor Running due to motor reverse rotation or Phase failure.
Trip Temperature	If the Discharge Temperature exceeds the set trip temperature value.
Sump Pressure Not Developing	After the Start, The Sump Pressure should be at least 0.3 bar /psi after star delay expires. If this is NOT achieved this Fault occurs
Power failure	If the Mains Supply is Interrupted for more than 20 m sec
Low Voltage	If the Mains Supply Voltage is less than the 67% of rated Voltage. Compressor is tripped & All Controller Operation is Halted until the Mains Supply Comes back to normal (at least 75% of the rated)
Dis. Pressure Not Developing	After the Load, The Discharge Pressure should be at least 0.5 bar/ psi in 5mins. If this is NOT achieved this Fault occurs
Dryer Trip	If dryer is enabled with Trip, this fault will occurs

Message 3 - Compressor Warning messages

Warning	Description
DPAF	If DPAF Digital Input is Open and DPAF ON in factory setting
DPOF	If DPOF Digital Input is Open and DPOF ON in factory
Dryer Probe Failure	When Ch-4 analog sensor input fails
Low Dew Point	When Ch-4 Dew point temp. is less than Set value
High Dew Point	When Ch-4 Dew point temp. is greater than Set value
High Differential Pressure	When the difference between Sump. Pressure and Discharge Pressure exceeds the Set Pressure. (Only in Sump Pr. Enabled condition)
Warn Temperature	When Discharge temp. exceeds the set warn temperature (Default is 105Deg C / Deg F)
Change Oil Filter	When Service reaming Hr. reaches 0000 Hrs
Change Air Filter	When Service reaming Hr. reaches 0000 Hrs
Change Oil	When Service reaming Hr. reaches 0000 Hrs
Change Grease	When Service reaming Hr. reaches 0000 Hrs
Change Separator	When Service reaming Hr. reaches 0000 Hrs
Dryer Warn	If Dryer Digital Input is Open

6.1 Important Machine Settings for Users:

1. Control Mode

- * Local – User can Start and Stop the Compressor by using local Start/Stop key
- * Remote – User can Start and Stop the Compressor by using Potential Free Digital Input.
(Refer Digital Input Connector – X04).
- * DCS – User can Start and Stop the Compressor by using RS485 Modbus communication port
(Refer Connector - X07).

NOTE: If in case of Emergency users are advised to stop the compressor using “Emergency Stop Push Button” available in the front Panel. This is applicable for all the control Mode explained above.

2. Unload Mode

If this Enabled, Compressor will run only in unload mode and it will never allow compressor to run in Load mode. (This mode is used for service and maintenance purpose).

3. Auto Restart

If this Enabled, Compressor will run automatically after power failure and it resumes based on previous condition. Default 90 sec delay given in the factory

4. Load / Unload Pressure:

Compressor will run between Load and Unload pressure based on Compressed Air Utilization.

5. Warn RST Delay

It is used to delay the compressor start after power resumes if Auto Restart Mode is ON.

6. Star Delay

Star to Delta change over delay time. Default 6 sec delay given in the factory.

7. DTR Delay

From Delta change over to Load delay time. Default 10 sec delay given in the factory.

8. RTS Delay

Normal Stop of compressor will Unload and wait for this delay time to Stop the Compressor. Default 10 sec delay given in the factory.

9. Standby Time

Compressor will go to Standby if Unloading exceeds the specified time. Default 5 mins set in the factory.

Standby resume - If the actual pressure is less than Load Pressure then compressor will restart automatically. This feature will save the Energy if utilization of compressed air is less.

10. Start/Stop Per Hour

System will warn if the compressor is started more than the specified no of cycles per hour.

Default 5 per Hour is set in the factory.

NOTE: In case compressor is started more than the specified no of cycles per hour through Standby sequence then system will not enter into standby stop sequence until the existing hour completion. Mean time Standby override will display on screen.

11. Auto Drain Valve

Auto Drain Valve is a special feature which is used to prevent the water molecule entry into the compressed air delivery. This function enables the drain valve to ON and OFF based on specified time in the Menu. Default 5 Sec ON in 4 mins interval.

12. Low Dew Point

System will warn if the dew point temperature is less than the set value

(If Dryer is enabled).

13. High Dew Point

System will warn if the dew point temperature is higher than the set value

(If Dryer is enabled).

14. Load/Unload Source

- * Local: Load/Unload pressure is based on local settings and Digital Input will response for DPAF, if DPAF is enabled.
- * Remote selection from Digital input - Load/Unload can be Operated from Remote
- * DCS: Load/Unload can be operate from DCS (Load/Unload Command Should be Given Continuously in the interval ≤ 3 sec)

NOTE: Compressor start working in local load and unload if communication lost in DCS mode

15. VFD Function

VFD speed % will display in the HOME screen once VFD mode is enabled in factory setting.

Also user can view the below VFD parameter by accessing view->VFD menu 5.1.6

1. Voltage in V
2. Current in A
3. Frequency in Hz
4. Power in KW
5. RPM
6. Status of the VFD

VFD Operation as follows

1. Machine will be run at Minimum speed (default 750RPM) up to RUN LOAD condition when start up.
2. Machine will be run at Unload speed when machine in Unload, it may be Remote Unload or DCS unload or when Dis. Pr is \geq UnLoad Pressure
3. Machine will be run at Optimum speed when Optimum is ON. (Only Load condition)
4. Machine will be run at Calculated Speed between Min.speed to Max.speed Based on the customer Utilization when machine in Load with Optimum is OFF.

7.0 Menu Structure

Press any one of the following keys ▲, ▼, ◀ and ▶ to enter main menu

Main Menu

```
Dis. Pr: 0.0 bar/psi
Dis. Tr: 25 °C
Status
▶ View
  Operator
  Service
  Factory
  Customer Care
```

```
Dis. Pr : 0.0 bar/psi
Dis. Tr : 25 ° C
Status
▶ Admin
```

7.1 View

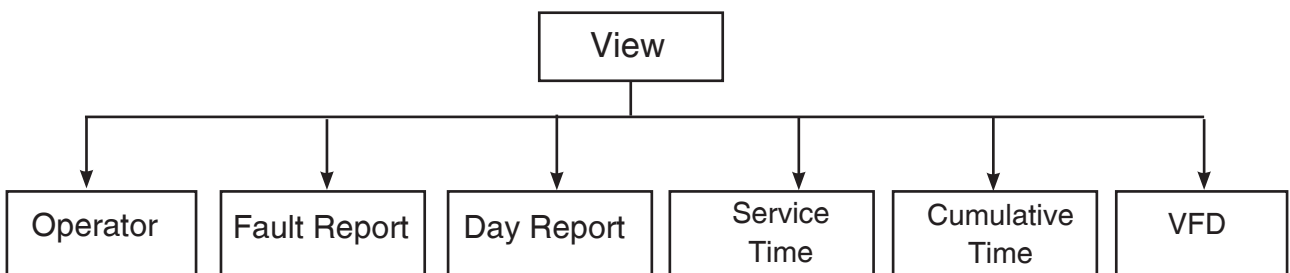

7.1.1 Operator

LEVEL 1	LEVEL 2	LEVEL 3	LEVEL 4	
View	Operator	Mode	Control mode	Local / Remote / DCS
			Auto Restart	ON/ OFF
			Pressure Unit	PSI / Bar/psi
			Temperature Unit	Fahrenheit / Centigrade
		Pressure	Unload pressure	X X . X b or p (bar/psi or psi)
			Load pressure	X X . X b or p
			Pr. Schedule	ON/ OFF
			Start Sump Press	X X . X b or p
			Max .Diff Pressure	X X . X b or p
		Delay	Warn RST delay	X X X s (second)
			Star delay	X X s
			DTR delay	X X s
			RTS delay	X X s
			Stanby Time	X X m (minute)
			St/Sp PH	X X
		DCS port	Type	Modbus
			ID	X X
			Baud	9600/19200
			Parity	None / Even / Add
			Length	8 / 7
			Stop Bit	2 / 1
		Temperature	Trip Temperature	X X X C or F
			Warn Temp	X X X C or F
			Fan Temp	X X X C or F
		Rating	XXXXXXXXXXXX	
		Fab NO	XXXXXXXXXXXX	

7.1.2. Fault Report

Use ▲, ▼ to select the Fault Record number (1 to 99).

LEVEL 1	LEVEL 2	LEVEL 3
View	Fault report	Fault Message
		Date: DD/MM/YY
		Time: HH:MM:SS
		Dis.Pr: X X .X
		Dis.Tr: X X X
		Status: RDY/ACK/STAR etc.,

Fault Message:

HSP (AD) – Discharge Pressure High, Pressure Probe Fail, Temperature High, Temperature Probe Failure, HSP (AS) – Sump Pressure High, Sump Pressure Probe Fail, Low Voltage,

Main Motor Overload, Cooler Motor Overload, Reverse Rotation, Discharge Pressure Not Developing, Sump Pressure Not Developing , Power Interruption, Phase Loss / Reverse, Dryer Trip.

7.1.3 Day Report

Use ▲, ▼ to select the Record number (1 to 30).

LEVEL 1	LEVEL 2	LEVEL 3
View	Day report	Date: DD/MM/YY
		L: X X Hours St: X X Hours
		UL: X X Hours F: X X Hours
		R: X X Hours Sby: X X Hours
		STC: X X X LDC: X X X X X

L- Load, St – Stop, UL – Unload, F- Fault, R- Run, Sby- Standby, STC – Start Count, LDC - Load Count

7.1.4 Service Time

LEVEL 1	LEVEL 2	LEVEL 3
View	Service time	Remaining AFCT: X X X X hours
		Remaining OFCT: X X X X hours
		Remaining OSCT: X X X X hours
		Remaining OCT: X X X X hours
		Remaining RGT: X X X X hours

7.1.5 Cumulative Time

LEVEL 1	LEVEL 2	LEVEL 3
View	Cumulative time	Load X X X X X X hrs: X X Min
		Unload X X X X X X hrs: X X Min
		Run X X X X X X hrs: X X Min
		Stop X X X X X X hrs: X X Min
		Fault X X X X X X hrs: X X Min
		Standby X X X X X X hrs: X X Min
		Start Count X X X X X X
		Load Count X X X X X X X X
		Utilisation X X %

7.1.6 VFD

If VFD is connected to the compressor and VFD port is connected, user can view the following parameters of VFD in Neuron II.

1. Voltage in V
2. Current in A
3. Frequency in Hz
4. Power in KW
5. RPM
6. Status of the VFD

7.2 Operator

Password required.

Operator	Machine
	Scheduler
	Maintenance
	Language
	Change Password
	VFD Control

7.2.1 Machine

S.no	Item	Min	Max	Option	Default	Unit
Mode						
1	Control mode	-	-	loc/rem/dcs	loc	-
2	Auto Restart	-	-	on / off	off	-
3	Pr Unit	-	-	bar / psi/psi	bar/psi	-
4	Tr Unit	-	-	cen / fah	cen	-
Pressure						
5	Unload Pressure	> load pressure+0.5 (bar/psi)	< max unload pressure (bar/psi)	-	7.5 bar/psi	bar/psi/psi
6	Load Pressure	4.0 (bar/psi)	< unload pressure-0.5 (bar/psi)	-	5.5 bar/psi	bar/psi/psi
Set Delay						
7	Warn RST	90	250	-	90	second
8	Star	6	20	-	6	second
9	DTR	10	60	-	10	second
10	RTS	5	30	-	10	second
11	Standby	1	99	-	5	minute
12	St/Sp per hr	3	20	-	5	-
DCS Port						
13	Type	-	-	Modbus		-
14	ID	01	99	-	01	-
15	Baud	-	-	9600/19200	9600	bps
16	Parity	-	-	None /Even / Odd	None	-
17	Length	-	-	8 / 7	8	-
18	Stop Bit	-	-	2 / 1	1	-
Auto Drain Valve						
19	Off time	1	180	-	4	minute
20	On time	1	15	-	5	Second
Set Dew Point						
21	Low Dew point	-6 C	+2 C	-	-2 C	C/F
22	High Dew point	6 C	12 C	-	8 C	C/F
Load / Unload Source						
23	LD / UL Source	-	-	Loc / Rem / DCS	Loc	-

7.2.2 Schedule

Enable Pressure Schedule, and then use ▲, ▼ to select the schedule number (1 to 32). (one schedule should be in Sunday (first day of the week) 00:00 Hrs)

Then Press “Enter” to set the following

S.no	Item	Min	Max	Option	Default	Unit
1	Day	-	-	Sun to Sat (--- means no schedule)	---	-
2	Action	-	-	on / off	off	-
3	Time HH	00	23	-	00	Hour
4	Time MM	00	59	-	00	Minute
5	Unload Pressure	>= Load Pressure + 0.5 (bar/psi)	<= Max Unload Pressure (bar/psi)	-	7.5 bar/psi	bar/psi/psi
6	Load Pressure	4.0 bar/psi	<= Unload Pressure – 0.5 (bar/psi)	-	5.5 bar/psi	bar/psi/psi

7.2.3 Maintenance

S.no	Item	Min	Max	Option	Default	Unit
1	AF changed	-	-	no/yes	no	-
2	OF changed	-	-	no/yes	no	-
3	OS changed	-	-	no/yes	no	-
4	Oil changed	-	-	no/yes	no	-
5	Re Grease	-	-	no/yes	no	-

If users changed the Filter and entered Yes then Set Filter time from Service / Maintenance will be replaced for the remaining time automatically.

7.2.4 Language

S.no	Item
1	English
2	Portuguese
3	Francais
4	Italiano
5	Spanish

Default is English.

7.2.5 VFD Control

Item	Min	Max	Default	Unit
Optimum Speed	on/off	on/off	off	
P-Gain	0	50000	250	
I-Gain	0	5000	500	
I-Time	0	200	20	
Max.Speed	Factory settings can be viewed here			RPM
Min.Speed				RPM
Optimum Speed				RPM
UL Speed				RPM
High (5v)				
				RPM
Low (1v)				RPM

VFD Speed Control

Min Speed: Compressor remains in Min Speed upto until the start “Run Load” condition during start.

PI Speed Control: In “Run Load”, Compressor operates at calculated Speed between Min speed to Max speed depends on air utilization/Usage.

Unload Speed: Compressor runs at settable Unload speed during Unload. This is irrespective of all unload modes lime Remote, DCS and Local Unload

Optimum Speed: Compressor runs at Optimum speed when in Load with Optimum is ON. (Factory Menu)

Pre-Check before start the compressor in VFD control

- * VFD should be enabled in **Factory -> VFD Settings** to read and write between VFD and Neuron II.
- * Ensure Modbus Communication exist between VFD and Neuron II by viewing the VFD RPM Range in Factory AO Scaling menu. Current VFD RPM will be displayed here, if communication lost it will display as -----
- * Ensure Min reference of AO scaling \geq VFD Parameters 3-02 and 4-11 & Max reference of AO scaling \leq VFD Parameters 3-03 and 4-13.

NOTE: Though there is no communication exist between Neuron II and VFD, it is still possible to operate the compressor with VFD control. But it has to be manually entered and ensured that the Min reference and Max reference has been written into VFD parameters 6-14 and 6-15 respectively. Else the speed control will still happen but to the existing values already available in these parameters

Setting the P Value

P-Gain – Range: 0 -50000. This gain is given full range. The recommended setting is 20 – 1000.

The lower the setting will make the PI loop correction to start early i.e.

Example :

- * If P value is set to 20 , makes the PI loop to start when the pressure difference between Set and Actual is 5.0 bar/psi
- * If P value is set to 1000, makes the PI loop to start when the pressure difference between Set and Actual is 0.1 bar/psi
- * Hence, if the compressor has higher receiver capacity then the change in pressure will be less (slow response system) there we have to set the higher value. Similarly if compressor has low receiver capacity and the pressure shoots up quickly there the P gain value should be less.

Setting the I Value

I- Gain – Range: 0-5000. This gain is given full range. The recommended setting is 50– 1000.

The recommended value is 125 to 250 in our case. Anything less than 125 will be more stable.

The lower setting make the system tolerant to the error. A value 50 for I-gain will make the system to correct the error only if the pressure difference between set and actual exceeds 0.020 bar/psi.

The higher setting make the system to sensitive to very small changes. E.g. A value of 1000 to I-Gain value make the system sensitive to 0.001bar/psi difference. A very high value and sensitive system (low receiver capacity), will drive the system into completely unstable state. Always try to keep lower values of I-Gain.

Setting I term

I-time – Range: 0-200. This indirectly counts the scan time.

The recommended value is 15 – 20.

A higher value delay the application of correction calculated based on the I-Gain and vice versa

7.2.6 Change Password

Procedure for changing the password

1. Enter the old Password
2. If old password is correct, next screen is displayed. If wrong means Incorrect password message will be displayed.
3. Enter the New password
4. Enter the New password again
5. If the new password matches both the times then new password is updated. If mismatch the control goes back to step 4.

Pressing Esc will bring the control to the previous screen

7.3 Service

Password required.

Service	Calibration (Offset)
	Relay
	Temperature
	Maintenance
	Clock
	Self - Test
	Password
	Digital Input
	Dryer Input
	Unload Mode

7.3.1 Calibration (Offset)

Select the parameter need to calibrated using the ▲, ▼ keys. Then Press “Enter” to calibrate.

Dis Pressure/Dis Temperature/Dew Point Temperature/ Sump Pressure Offset Calibration.

Dis.Pressure / Sump Pressure:

Feed some known current value (4 – 20mA) in pressure channel using a standard & recently calibrated meter and enter the offset difference in Neuron II. Allowable Range is +/- 0.5 bar/psi.

Dis Temperature/Dew Point Temperature :

Feed some known Resistance value between 1456 to 4433 ohm for KTY10 / 960 to 1573 ohm for PT1000 in Temperature channel using a standard & recently calibrated meter and enter the offset difference in Neuron II. Allowable Range is +/- 5 Deg C/ Deg F.

NOTE: Calibration must be carried out only when the compressor is in off condition and the digital outputs (relay terminals) are disconnected from the controller.

NOTE: Calibration for Pressure will be only in bar/psi and for temperature only in Centigrade.

7.3.2 Relay

Select the Programmable Relay 1 or 2 using the ▲, ▼ keys. Then Press “Enter” to assign the any one of the following functionality for the relay.

S.no	Item
1	Warn
2	Load
3	Service
4	Standby
5	Trip
6	Remote
7	Ready

Default:

Relay 1 = Warn

Relay 2 = Trip

Note: If Dryer is enabled then Programmable Relay 2 is not user programmable. It is used for automatic dryer control.

7.3.3 Temperature

S.no	Item	Min	Max	Option	Default	Unit
1	Fan Temp	60 C	85 C	-	85 C	C/F
2	Inhibit Temp	-5 C	5 C	-	0 C	C/F

- Fan Temperature** – Fan relay will energize if discharge temperature reaches the set value and it will de-energize when the temperature decreases to -10 °C from the set value.
- Inhibit Temperature** – Compressor will allow to start when the discharge temperature is higher than the set value (if Temperature Inhibit is Enabled in Factory settings).

7.3.4 Maintenance

#	Item	Min	Max	Option	Default	Unit
1	Set AFCT	0000	30000	-	2000H	Hour
2	Set OFCT	0000	30000	-	2000H	Hour
3	Set OSCT	0000	30000	-	4000H	Hour
4	Set OCT	0000	30000	-	2000H	Hour
5	Set RGT	0000	30000	-	2000H	Hour

System will warn when it reaches 0000 hours and customer need to change the filter accordingly. Based on models it will vary, please refer for your authorized dealers.

Customers are advised to register in operator/Maintenance menu once the filter is replaced.

7.3.5 Clock

S.no	Item	Min	Max
1	Date Format	DD/MM/YY	MM/DD/YY
2	Time Format	12 hr	24 hr
3	Day light savings	0	2

Date Format is applicable for all menus where as 12hr Time Format is applicable for home screen only.

Day light saving settings will add 1 or 2 hours from current GMT time.

S.no	Item	Min	Max
1	Hour	00	23
2	Minute	00	59
3	Second	00	59
4	Date	01	31
5	Month	01	12
6	Year	00	99
7	Day	Sun/Mon/Tue/Wed/Thu/Fri/Sat	

7.3.6 Self Test

Self Test for testing the Controller Display, Mimic Led's, Keys, Analog and Digital Input/Outputs.

Follow the instructions displayed in the screen.

Warning!!!

Self Test should be conducted only when the compressor wiring is totally disconnected from the controller. **Do NOT** perform self test when the controller is connected to the compressor. Doing so will cause severe damage to the compressor. **Self Test must do the authorized service person only.**

7.3.7 Change Password

Procedure for changing the password

1. Enter the old Password
2. If old password is correct, next screen is displayed. If wrong means incorrect password message will be displayed.
3. Enter the New password
4. Enter the New password again
5. If the new password matches both the times then new password is updated. If mismatch the control goes back to step 4.

Pressing Esc will bring the control to the previous screen

7.3.8 Digital Input

Configured of DI-4 (DPAF or Remote Load/Unload) can be viewed from this menu. (if Load/Unload Source is selected as Remote in Operator -> Machine settings).

7.3.9 Dryer Input

Dryer digital input DI-6 configured for Warn or Trip, This input will be effective if Dryer is ON in Factory -> Dryer.

7.4 Factory menu

Password required.

Factory	Machine
	Dryer
	Password
	VFD Settings
	VFD Settings
	AO Scaling

7.4.1 Machine

#	Item	Min	Max	Option	Default	Unit
Compressor Info						
1	Rating	-	-	Manual Entry 10 digit alphanumeric	22	KW
2	Fab No	Editable alpha numeric			-	-
3	DPAF	-	-	on/off	off	-
4	DPOF	-	-	on/off	off	-
Max. Pressure Settings						
6	Max UL Pressure	>= 4.5 bar/psi	<= 15.5 bar/psi	-	7.5 bar/psi	bar/psi/psi
7	High Sump Pressure	>= Max Unload pressure +0.5 bar/psi	<= Max Unload pressure +3	-	8.0 bar/psi	bar/psi/psi
8	Sump Pressure	-	-	enable/disable	disable	-
9	Start Sump Pressure	0.1 bar/psi	16.0 bar/psi	-	1.0 bar/psi	bar/psi/psi
10	Max. Differential Pressure	0.1 bar/psi	2.0 bar/psi	-	2.0 bar/psi	bar/psi/psi
Temperature Settings						
11	Trip temperature	80 C	120 C	-	110 C	C / F
12	Warn temperature	70 C	115 C (Trip.Tr – 5Deg C/Deg F)	-	105 C	C / F
13	Temperature Inhibit	-	-	Enable / Disable	Enable	-

Rating - Compressor capacity and model information.

DPAF and DPOF for selective models only.

Max. UL Pressure – Maximum allowable Unload Pressure settings.

HSP – Compressor will Trip immediately if the Discharge Pressure or Sump Pressure exceeds the set limits.

Sump Pressure En/Dis – For Selective models only.

Start Sump Pr – If Sump is Enabled then compressor will allow to start when the sump pressure is less than the set value.

Max. diff Pr. – If Sump is Enable then Compressor will warn if the difference between Discharge Pressure and Sump Pressure is higher than the set value,

Trip Temperature – Compressor will Trip if the Discharge Temperature is higher than the set value.

Warn Temperature - Compressor will warn if the Discharge Temperature is higher than the set value.

Temperature Inhibit – Enable / Disable option for Temperature based Start Inhibit for more details refer Service/Inhibit Temperature option.

7.4.2 Dryer

S.no	Item	Min	Max	Option	Default	Unit
1	Dryer Mode	-	-	on/off	off	-
2	Dryer Delay	2	10	-	3	Minute

If Dryer Model is selected then Programmable relay2 is fixed for Dryer and dryer relay will energize after the set delay expires from last Stop. Compressor will warn or trip based on Dryer Input selection when digital Input is connected (refer Connector X04). This Dryer control works only after RUN state.

7.4.3 Change Password

Procedure for changing the password

1. Enter the old Password
2. If old password is correct, next screen is displayed. If wrong means Incorrect password message will be displayed.
3. Enter the New password
4. Enter the New password again
5. If the new password matches both the times then new password is updated. If mismatch the control goes back to step 4.

Pressing Esc will bring the control to the previous screen

7.4.4 VFD Setting

VFD En/Dis	Enable / Disable
Max.Speed	Max.Speed values can be set between (Min.speed+100) to High reference RPM of AO Scaling
Min.Speed	Min.Speed values can be set between Low reference of AO Scaling to (Max.speed-100) RPM
Optimum Speed	Optimum speed values can be set between Min.speed to Max.speed RPM
UL Speed	Unload speed values can be set between Min.speed to (Max.speed-100) RPM

7.4.5 AO Scaling

Item	Min	Max	Default	Unit
High(5V) - High ref.	Low.Ref.+100	3000	1470	RPM
Low(1V) - Low ref.	750	High.Ref-100	750	RPM
VFD's Current set Low and High RPM will be displayed here				

Menu (Factory -> AO SCALING) for Common settings for All VFD

Step 1 : Set Analog Output **Low reference** Scale of VFD (1V). This value between 750 to (High reference-100) RPM, it must be Greater than or Equal to 3-02 and 4-11 parameters of VFD and it will be written into 6-14 parameters of VFD.

Note that the minimum speed the compressor can run is limited by maximum of any one of these settings. Say the parameters contain 750, 900 and 1000 in parameter 3-02,4-11 and 6-14 respectively. The minimum speed is limited to 1000 rpm.

Step 2 : Set Analog Output **High reference** Scale of VFD (5V). This value between Low reference+100) to 3000 RPM, it must be Lesser than or Equal to 3-03 and 4-13 parameters of VFD and it will be written into 6-15 parameters of VFD.

Note that the maximum speed the compressor can run is limited by minimum of any one of these settings. Say the parameters contain 1500, 1600 and 1800 in parameter 3-03,4-13 and 6-14 respectively. The maximum speed is limited to 1500 rpm.

7.5 Customer care

Dis. Pr	: 6.0 bar/psi
Dis. Tr	: 32 °C
Status	
S/W Version	
URL www.elgi.com	
e-mail: ccs@elgi.com	

7.6 Admin

Password required.

Admin menu is used for Analog Input Calibration, Analog Output Offset Adjustment , Report Resets (Day Report/Fault Report/ Cumulative/Service hours/Password).

8.0 Data Interface

Neuron II has two types of Data Interface

- * Analog output
- * DCS Port

8.1 Analog output

Two Channels are available as analog output. Channel - 1 for Discharge Pressure values from 0.0 to 16.0 bar/psi, converted into 1 to 5V.

Channel - 2 for Discharge temperature value from -10 to 150 Deg C/ Deg F, converted into 1 to 5V

NOTE: If in case of Analog Input probe failure, analog output would be OV by default.

8.2 DCS Port

DCS port is Modbus RTU type to interface to Generic DCS system.

User can set the Device ID in menu “**Operator/ Machine/ DCS Port**”. Also Baud Rate, Parity, data Length, Stop Bit are user settable. The Modbus data table is provided in the Appendix.

9.0 Construction

- * Corrosion & Dust protected Back Cover
- * IP65 polyethylene front keypad
- * Inputs and Outputs through terminal block
- * Front Plate Dimensions 260 x 145mm
- * Enclosure Dimensions 235 X 120 X 70 mm

9.1 Dimension Drawing

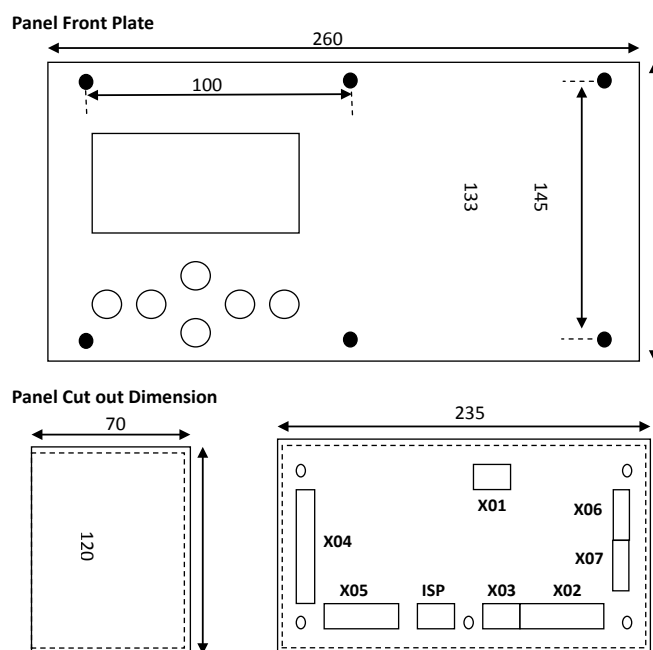

All Dimensions are in mm

10.0 Example – scheduler setting

Page 1/2

The settings are considered
When

- 1 End customer usage is 6 bar
- 2 Pressure variation in the air pipe is less than 0.1b
- 3 All the 3 compressor are connected in a sigle/Common Header
- 4 All the 3 compressor are connected in a Common receiver

Pressure schedule settings in Neuron-2														
	Comp-1					Comp-2					Comp-3			
	ON	OFF	Load	U/L		ON	OFF	Load	U/L		ON	OFF	Load	U/L
Day-1	Lead					Lag					Lag			
	8:00	18:00	7	7.5		8:00	18:00	6.6	7.2		8:00	18:00	6	6.8
Day-2	Lag					Lead					Lag			
	8:00	18:00	6	6.8		8:00	18:00	7	7.5		8:00	18:00	6.6	7.2
Day-3	Lag					Lag					Lead			
	8:00	18:00	6.6	7.2		8:00	18:00	6	6.8		8:00	18:00	7	7.5
Day-4	Lead					Lag					Lag			
	8:00	18:00	7	7.5		8:00	18:00	6.6	7.2		8:00	18:00	6	6.8
Day-5	Lag					Lead					Lag			
	8:00	18:00	6	6.8		8:00	18:00	7	7.5		8:00	18:00	6.6	7.2
Day-6	Lag					Lag					Lead			
	8:00	18:00	6.6	7.2		8:00	18:00	6	6.8		8:00	18:00	7	7.5
Day-7	OFF till Next week Day-1 8:00AM													

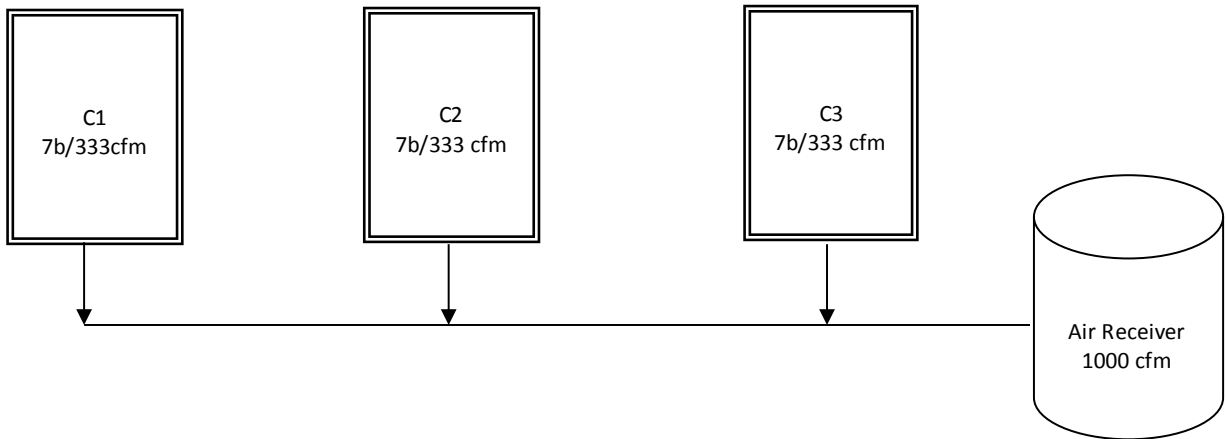

Weekly utilization

Comp->	Air Demand: 100%			Air Demand: 75%			Air Demand: 50%			Air Demand: 25%		
	C1	C2	C3	C1	C2	C3	C1	C2	C3	C1	C2	C3
Day-1	100	100	100	100	100	25	100	50	0	75	0	0
Day-2	100	100	100	25	100	100	0	100	50	0	75	0
Day-3	100	100	100	100	25	100	50	0	100	0	0	75
Day-4	100	100	100	100	100	25	100	50	0	75	0	0
Day-5	100	100	100	25	100	100	0	100	50	0	75	0
Day-6	100	100	100	100	25	100	50	0	100	0	0	75
Avg Util%	100	100	100	75	75	75	50	50	50	25	25	25

Conclusion

Equal Utilization of all the 3 Compressor based on Pressure demand

It reduces the power consumption since the compressors are utilised based on the demand.

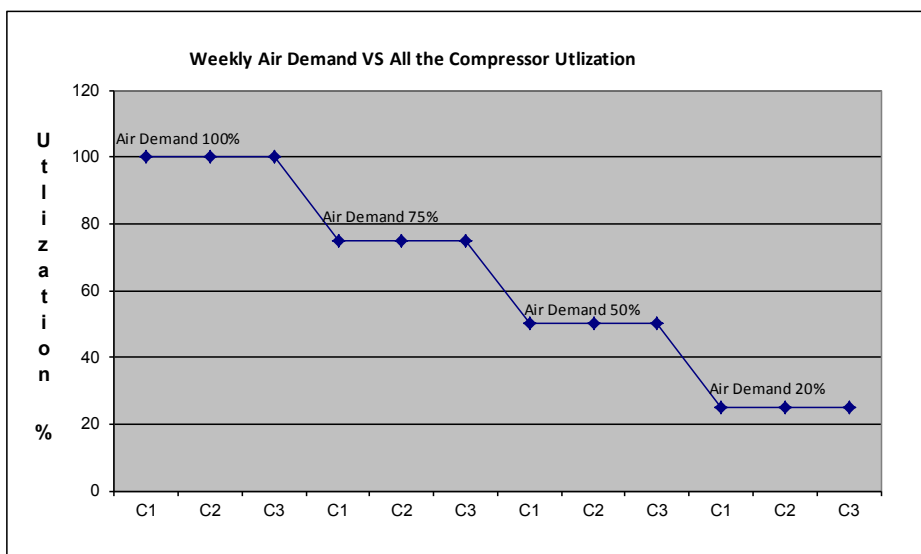

Neuron-2 Pressure Schedule Setup

- Step-1 Goto Operator Menu
- Step-2 Enter Password "4545"
- Step-3 Operator -> schedule
- Step-4 Enable
- Step-5 Set ON TIME
- Step-6 Set OFF TIME
- Step-7 Set Load Pr
- Step-8 Set Unload Pr.

11.0 MODBUS Details

Modbus address Table will be available on request

12.0 Revision Details

Version	Date	Changes
1.0	2 nd April 2009	Initial Draft
1.1	8 th July 2009	Pilot Batch S/W Version 1.1
1.3	5 th Nov 2013	1.1PK3 release 1
1.4	27 th Jan 2014	1.1PK3 release 2
1.5	7 th May 2014	1.1PK3 VFD additions
1.6	4 th June 2014	1. 1.1PK3 R04A2 Menu corrections 2. VFD PID setting described in detail
1.7	9 th Aug 2014	Change done for certification
1.8	14 th April 2015	Note added in I/O description

EG SERIES ELECTRIC POWERED SCREW AIR COMPRESSOR

EG 11 to EG 22
(15 HP to 30 HP)
Standard and Standard + VFD
208 - 230V / 460V, 3Ph, 60Hz

PARTS MANUAL

PARTS MANUAL

Drive System	4
Air Inlet & Control System	8
Discharge System	12
Cooler Box Sub Assy	14
Cooling System	16
Moisture Separator Sub Assy	18
Base and Canopy Assy	20
Airend Assembly	24
RDS Kit	30
Hose Parts List	32
Spare Kit	33
Insurance Kit Details	34
VFD Settings	36
Electrical Drawings	42
P & I Drawings	78
Decals	79
Disclaimers	

DRIVE SYSTEM E18 (25 HP) -100 & 125 PSI g & E22 (30 HP) - 100,125 & 150 PSI g

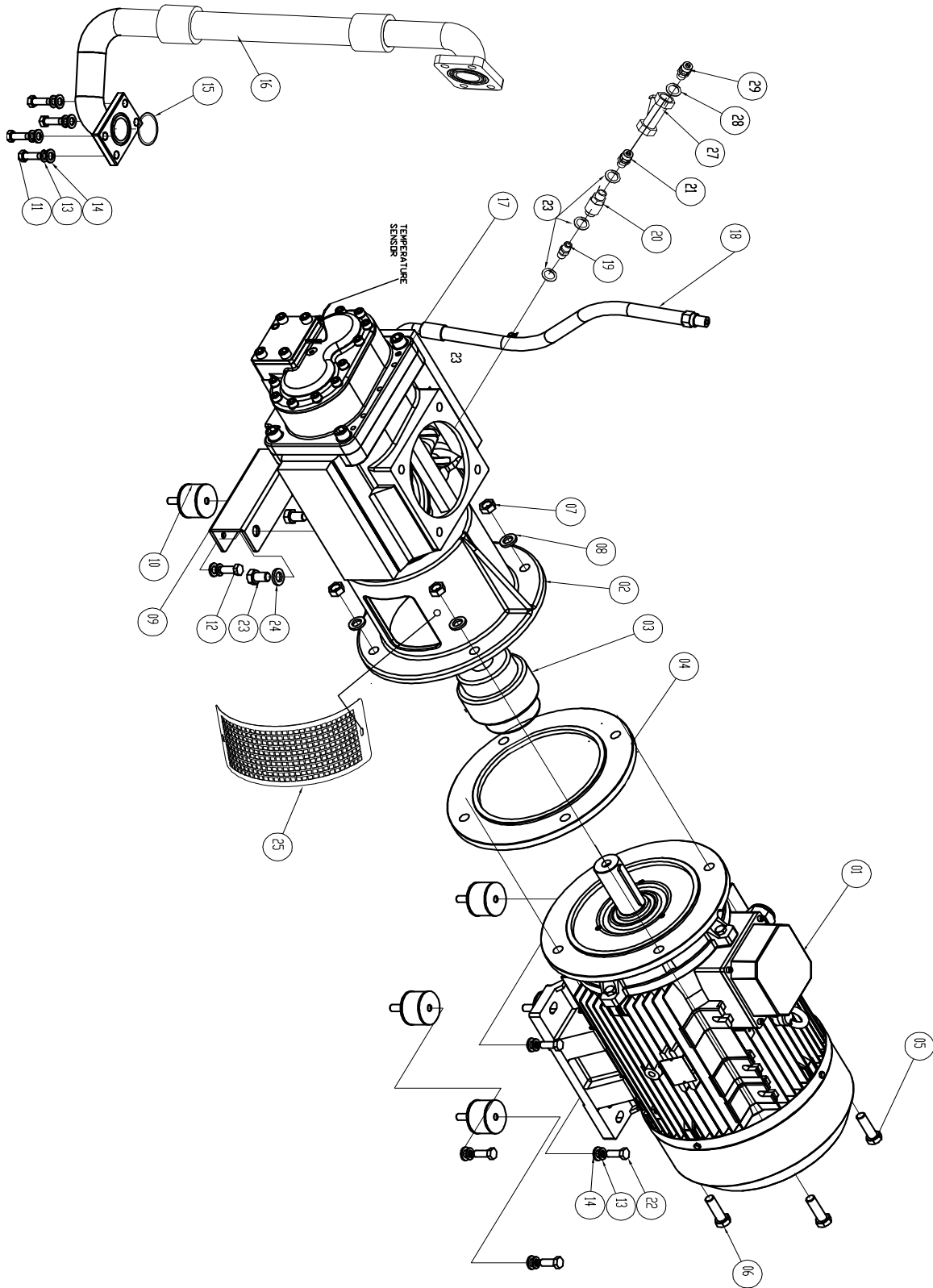

DRIVE SYSTEM E18 (25 HP) -100 & 125 PSI g & E22 (30 HP) - 100,125 & 150 PSI g

S.NO	PART NO.	DESCRIPTION	QTY.
1	B005106400007	MOTOR 18 kW (25hp)	1
	B005106400008	MOTOR 22 kW (30HP)	1
2	---	ADAPTER RING AND AIR END ASSY	
	X990459	AIREND ASSY -18kW - 100 & 22kW - 150	1
	X990456	AIREND ASSY -18kW - 125	1
	X990407	AIREND ASSY - 22kW - 100	1
	X990461	AIREND ASSY - 22kW - 125	1
	015305730	ADAPTER RING	1
3	B005405550018	DRIVE COUPLING	1
4	015402508	SPACER - ADAPTOR RING	1
5	000906219	HEX BOLT M16 X 65	3
6	000906222	HEX BOLT M16 X 80	1
7	000948016	HEX NUT M16	5
8	000996116	SPRING WASHER M16	4
9	015313389	AIREND MOUNTING BRACKET	1
10	B001401300003	ANTI VIBRATION MOUNT	5
11	000906184	HEX BOLT M12 X 35	4
12	000906181	HEX BOLT M12 X 20	1
13	000996060	PLAIN WASHER M12	9
14	000996112	SPRING WASHER M12	9
15	015402687	O - RING	1
16	015310460	DISCHARGE PIPE WITH HOSE ASSY	1
17	B01506720001	ORIFICE ADAPTOR	1
18	015312501	OIL INJECTION HOSE 1/2 INCH	1
19	990404070	ORIFICE 1mm, M-M	1
20	B004606240001	OIL SIGHT GLASS VALVE 1/8" - C	1
21	B009606780003	HEX REDUCER 1/4 X 1/8 BSP	1
22	000906185	HEX BOLT M12 X 40	4
23	000906211	HEX BOLT M16 X 25	2
24	000996061	PLAIN WASHER M16	2
25	015402623	COUPLING GUARD - 159 AIR END	2
26	000959381	BONDED SEAL WASHER 1/8	3
27	B008806100002	1/4" STRAINER ASSY	1
28	000959385	1/4" BONDED SEAL WASHER	1
29	B009606780009	PMS COUPLING 1/4 BSP X 6MM	1

**DRIVE SYSTEM E11-E15 (15 - 20 HP) - 100, 125 150 & 175 PSI g
E18 (25 HP) - 150 & 175 PSI g, E22 - 175 PSI g**

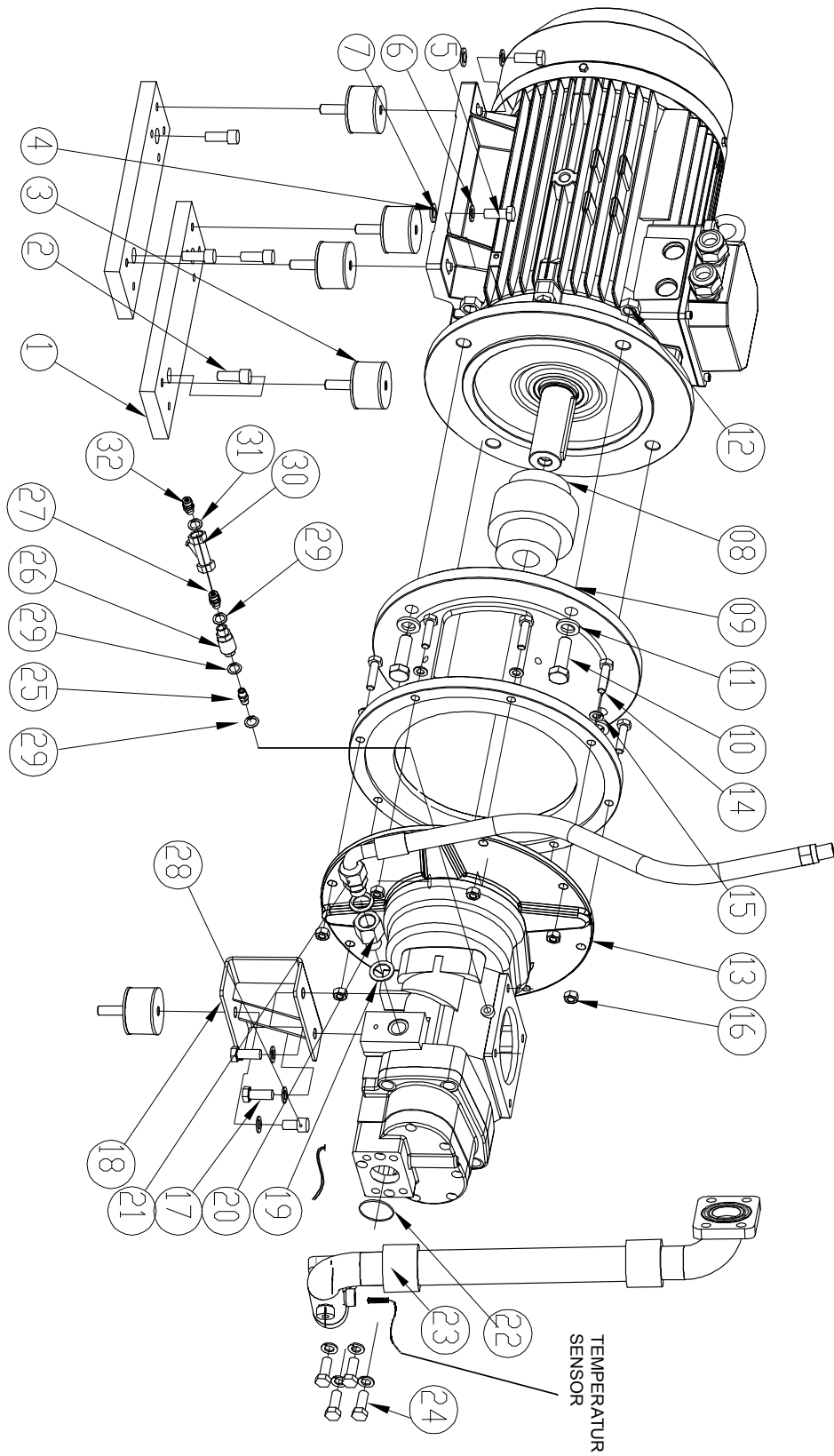

DRIVE SYSTEM E11-E15 (15 - 20 HP) - 100, 125 150 & 175 PSI g
E18 (25 HP) - 150 & 175 PSI g, E22 - 175 PSI g

S.NO	PART NO.	DESCRIPTION	QTY
1	015402509	MOTOR MOUNTING FLANGE	2
2	000983143	SCR SOC HD M12 X 30 10.9 ZYP5-8u	4
3	B001401300003	ANTI VIBRATION MOUNT	5
4	B005106400005	MOTOR 11 kW (15 HP)	1
	B005106400006	MOTOR 15 kW (20 HP)	1
	B005106400007	MOTOR 18 kW (25 HP)	1
	B005106400008	MOTOR 22 kW (30 HP)	1
5	000906183	HEX BOLT M12 X 30	4
	000906185	HEX BOLT M12 X 40	4
6	000996112	SPRING WASHER M12	4
7	000996012	PLAIN WASHER M12	4
8	B005405550016	DRIVE COUPLING - 11 & 15kW MODEL	1
	B005405550017	DRIVE COUPLING - 18 & 22kW MODEL	1
9	015305729	ADAPTER RING	1
10	000906218	HEX BOLT M16 X 60	3
11	000948016	HEX NUT M16	5
12	000996116	SPRING WASHER M16	4
13	X019357	AIREND ASSY 11 - 100 PSI	1
	X019311	AIREND ASSY 11 - 125 PSI	1
	X019309	AIREND ASSY 11 - 150 PSI	1
	X019307	AIREND ASSY 11 - 175 PSI	1
	X019355	AIREND ASSY 15 - 100 PSI, 18 -150 PSI	1
	X990206	AIREND ASSY 15 - 125 PSI	1
	X019316	AIREND ASSY 15 - 150 PSI	1
	X019314	AIREND ASSY 15 - 175 PSI	1
	X019356	AIREND ASSY 18 - 175 PSI	1
	X990169	AIREND ASSY 22 - 175 PSI	1
14	000906147	HEX BOLT M10 X 40	8
15	000996108	SPRING WASHER M8	8
16	000948008	HEX NUT M8	8
17	000906181	HEX BOLT M12 X 20	3
18	015401078	AIREND MTG BRACKET	1
19	B010506720004	ORIFICE ADAPTOR	1
20	B010506720001	ORIFICE ADAPTOR	1
21	015312501	OIL INJECTION HOSE 1/2 INCH	1
22	015400891	O - RING	1
23	015310677	DISCHARGE PIPE HOSE ASSY	1
24	000906184	HEX BOLT M12 X 35	4
25	990404070	ORIFICE 1mm, M-M	1
26	B004606240001	OIL SIGHT GLASS VALVE G 1/8 - C	1
27	B009606780003	HEX REDUCER 1/4 X 1/8 BSP	1
28	000983141	SOC HD M12 X 20	1
29	000959381	1/8 BSP BONDED SEAL WASHER	3
30	B008806100002	1/4 STRAINER ASSY	1
31	000959385	1/4" BONDED SEAL WASHER	1
32	B009606780009	PMS COUPLING 1/4 BSP X 6 MM	1

AIR INLET & CONTROL SYSTEM

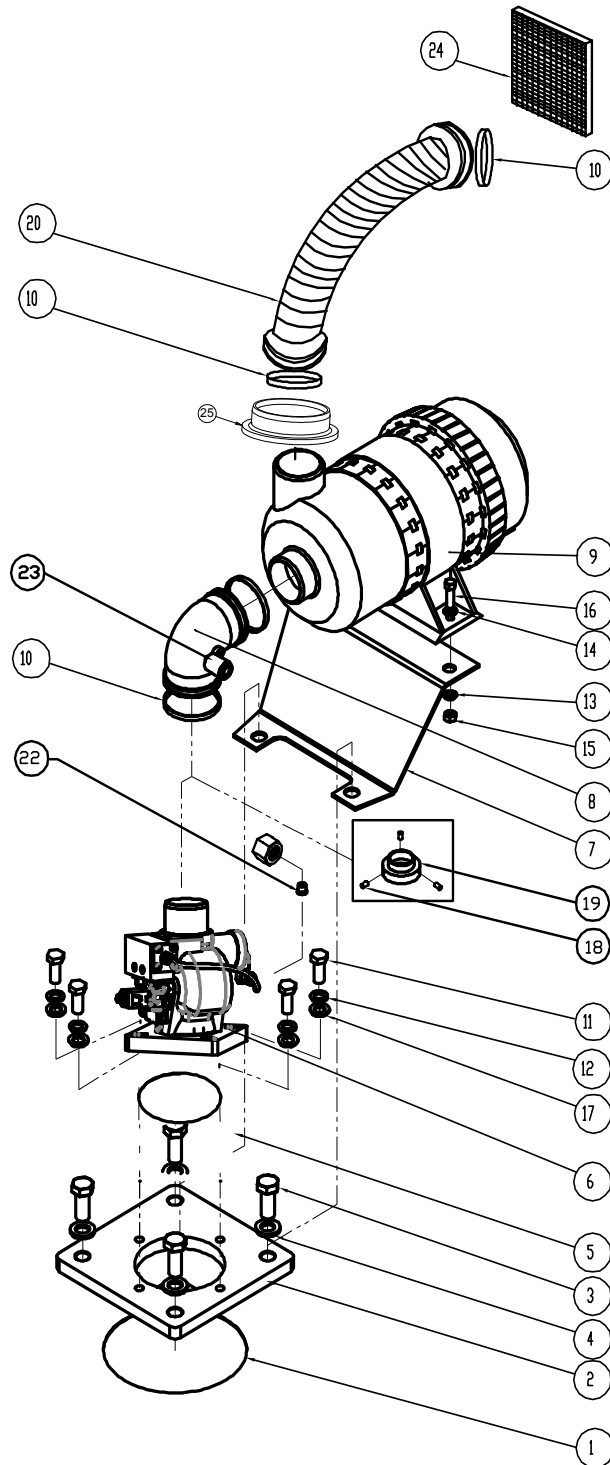

AIR INLET & CONTROL SYSTEM

EG 18 (25 HP) - 100 & 125 PSI g, EG 22 (30 HP) - 100, 125 & 150 PSI g

S.NO	PART NO.	DESCRIPTION	QTY.
1	015403271	O RING	1
2	015310676	ADAPTER INTAKE VALVE	1
3	000906214	HEX BOLD M16 X 40	4
4	000996116	SPRING WASHER M16	4
5	B015401070003	O RING	1
	015401050	GASKET	1
6	B009801070012	INTAKE VALVE - NC	1
7	015400928	AIR FILTER BRACKET (159 A-E)	1
	015401048	AIR FILTER BRACKET (102 A-E)	1
8	B004700770016	ELBOW 90° (18-22 kW)	1
9	B004700770002	AIR FILTER ASSY (18-22 kW)	1
10	B005000530003	ELBOW CLAMP (18-22 kW)	2
11	000906184	HEX BOLT M12 X 35	4
12	000996112	SPRING WASHER M12	4
13	000996108	SPRING WASHER M8	2
14	000996058	PUNCHED WASHER M8	2
15	000948008	HEX NUT M8	2
16	000906119	HEX BOLT M8 X 40	2
17	000996060	PLAIN WASHER M12	4
18	000986816	SCREW GRUB M6 X 6	3
19	015401213	SLEEVE STOPPER	1
20	B003506470001	SUCTION DUCT WITH END CUF	1
22	000959763	SLEEVE FOR 6 X 4MM TUBE	2
23	B004700770017	SERVICE INDICATOR	1
24	015400889	PREFILTER	1
25	015403827	RUBBER DUCT (11-15kW)	1

AIR INLET & CONTROL SYSTEM

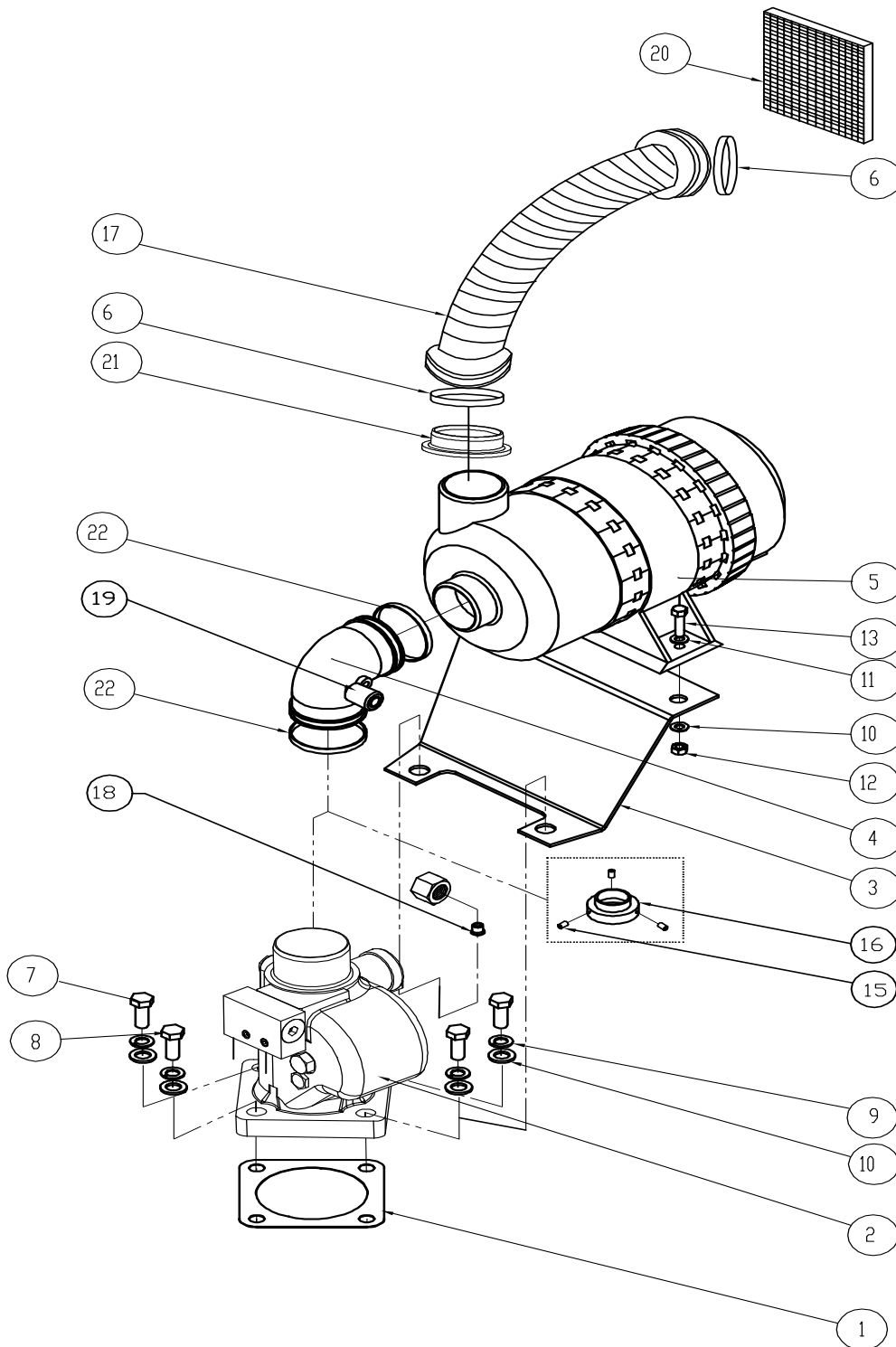

AIR INLET & CONTROL SYSTEM

EG 11 - EG 15 (15 - 20 HP) - 100, 125, 150 & 175 PSI g

EG 18 (25 HP) - 150 & 175 PSI g, EG 22 - 175 PSI g

S.NO	PART NO.	DESCRIPTION	QTY.
1	015401050	GASKET	1
2	B009801070012	INTAKE VALVE - NC	1
3	015400928	AIR FILTER BRACKET (159 A-E)	1
	015401048	AIR FILTER BRACKET (102 A-E)	1
4	B004700770015	ELBOW 90° (11-15 kW)	1
5	B004700770005	AIR FILTER ASSY (11-15 kW)	1
6	B005000530003	SS WORM CLAMP JW 6C13 -54-70	2
7	000906184	HEX BOLT M12 X 35	2
8	000906185	HEX BOLT M12 X 40	2
9	000996112	SPRING WASHER M12	4
10	000996108	SPRING WASHER M8	2
11	000996008	PLATE WASHER M8	2
12	000948008	HEX NUT M8	2
13	000906119	HEX BOLT M8 X 40	2
14	000996060	PLAIN WASHER M12	4
15	000986816	SCREW GRUB M6 X 6	3
16	015401213	SLEEVE STOPPER	1
17	B003506470001	SUCTION DUCT WITH END CUF	1
18	000959763	SLEEVE FOR 6 X 4MM TUBE	2
19	B004700770017	SERVICE INDICATOR	1
20	015400889	PREFILTER	1
21	015403827	RUBBER DUCT (11-15kW)	1
22	B005000530002	SS WORM CLAMP JW 6C 13 -44-60	2

DISCHARGE SYSTEM

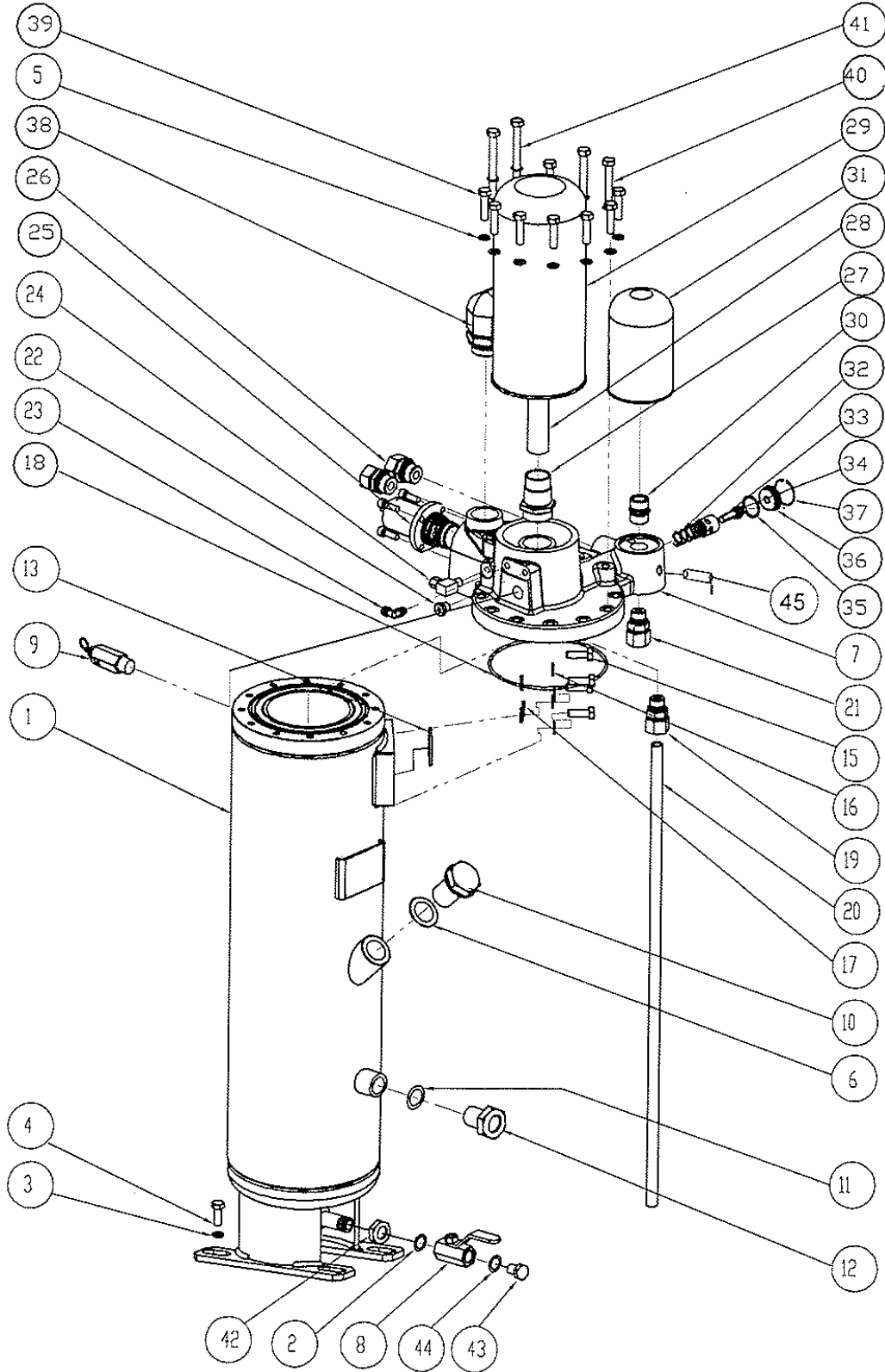

DISCHARGE SYSTEM

S.NO	PART NO.	DESCRIPTION	QTY.
1	015306841	SEPERATOR TANK ASSY ASME	1
2	000959387	1/2" BSP BONDED SEAL WASHER	1
3	000996112	SPRING WASHER M12	4
4	000906184	HEX BOLT M12 X 45	4
5	000996110	SPRING WASHER M10	12
6	000959439	1" BSP BONDED SEAL WASHER	1
7	015301535	SEPERATOR BLOCK BODY	1
8	B312717	1/2" BSP BALL VALVE	1
9	B012805340024	SAFETY VALVE	1
10	015402651	OIL FILL PLUG 1" BSP	1
11	000959438	3/4" BSP BONDED SEAL WASHER	1
12	015306521	OIL SIGHT GLASS 3/4"	1
13	015402687	O RING	1
15	000906145	HEX BOLT M10 X 30	4
16	000996110	SPRING WASHER M10	4
17	000996059	PLAIN WASHER M10	4
18	015400922	O RING	1
19	000959914	ST FITTING G1/2 TO 16 MM TUBE	1
20	015400912	OIL SUCTION PIPE	1
21	B010506780003	CONNECTOR 1/2 BSP W/O NUT	1
22	000959915	PLUG G1/8	1
23	B010501230004	1/8" NCH BSP MALE ELBOW	1
24	015403609	ELBOW; TMS; 1/4" X 1/4" NPT	1
25	B009301070008	MINIMUM PRESSURE VALVE	1
26	B010506780004	CONNECTOR 3/4 W/O NUT	2
27	015400875	SEPERATOR FILTER NIPPLE	1
28	015400877	INTERNAL PIPE	1
29	B006700770010	AIR OIL SEPERATOR	1
30	010440500	OIL FILTER NIPPLE	1
31	B004800770001	OIL FILTER	1
32	015401073	SPRING	1
33	015400932	PISTON	1
34	B008706030003	THERMAL ELEMENT 65° C	1
35	015400874	THERMAL PLUG	1
36	015400890	O RING	1
37	000917237	CIRCLIP B37	1
38	B010506780005	CONNECTOR 1-1/4 W/O NUT	1
39	000906147	HEX BOLT M10 X 40	8
40	000906153	HEX BOLT M10 X 70	2
41	000906159	HEX BOLT M10 X 100	2
42	020496120	LOCK NUT 1/2" BSP	1
43	340401400	HEX PLUG 1/2" BSP	1
44	090443950	O RING 1/2"	1
45	B013206660001	OIL SAMPLING VALVE 1/4" BSP	1

COOLER BOX SUB ASSY

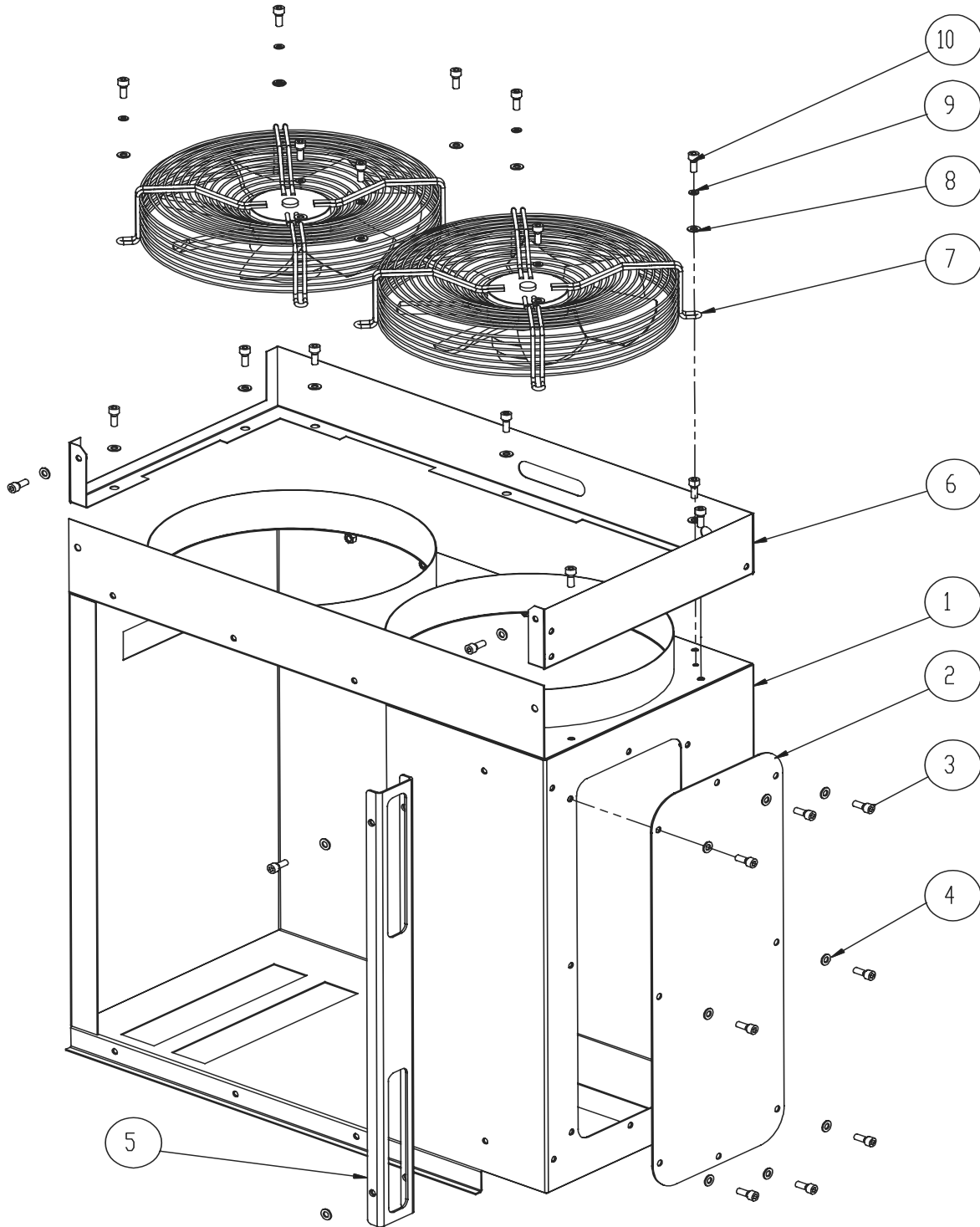

COOLER BOX SUB ASSY

S.NO	PART NO.	DESCRIPTION	QTY.
1	015312750	COOLER BOX ASSY	1
2	-	COOLER INSPECTION COVER	1
3	000983064	SCR SOC HD M6X20 10.9 ZYP	4
4	000996106	SPRING WASHER M6	4
5	015402391	COOLER BOX MOUNTING BRACKET	1
6	-	COOLER BOX TOP COVER	1
7	018400036	350 FAN- 3-230/400V +/- 10 D/Y 60 Hz (15-22 kW)	2
	018400036	350 FAN- 3-230/400V +/- 10 D/Y 60 Hz (11 kW)	1
8	000996058	PLAIN WASHER M8	8
9	000996108	SPRING WASHER M8	8
10	000906115	HEX BOLT M8 X 20	8
11	015403681	COVER PLATE - COOLER (11-15kW)	1

COOLING SYSTEM

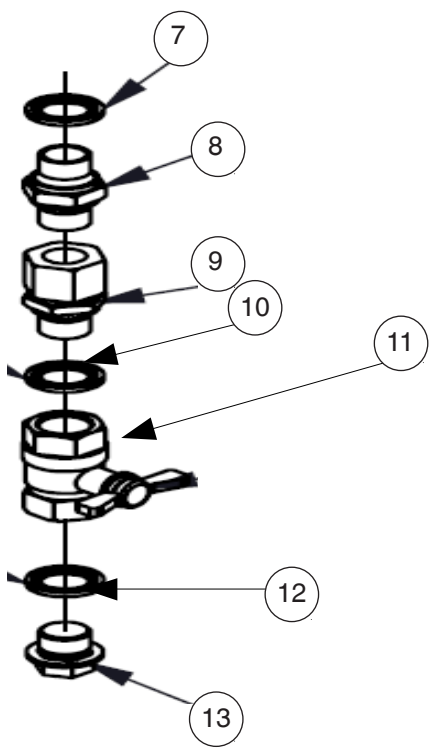
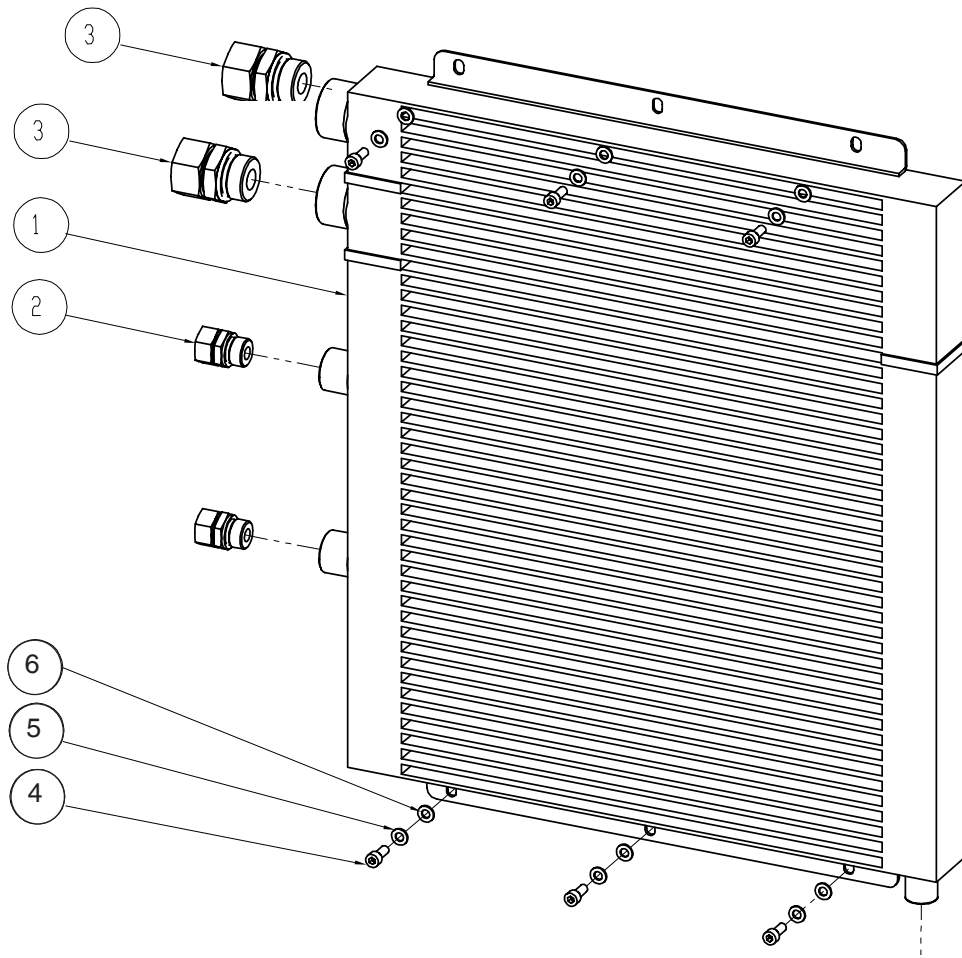

COOLING SYSTEM

S.NO	PART NO.	DESCRIPTION	QTY.
1	B007705830009	AFTER COOLER & OIL AIR COOLER ASSEMBLY (18-22 kW)	1
	B007700690022	AFTER COOLER & OIL AIR COOLER ASSEMBLY (11-15 kW)	1
2	B010506780004	CONNECTOR 3/4 W/O NUT	2
3	B010506780005	CONNECTOR 1 1/4 W/O NUT	2
4	000983083	SCR SOC HD M8 X 20 10.9 ZYP	6
5	000996108	WASHER SPRING REC SEC M8	6
6	000996058	WASHER PUNCHED M8	6
7	000959386	DOWTY WASHER 3/8"	1
8	B010506360041	CONNECTOR	1
9	B010506360042	ADAPTOR	1
10	000959387	DOWTY WASHER 1/2"	1
11	B003101230001	1/2" BALL VALVE	1
12	090443950	O RING	1
13	340401400	PLUG	1

EG11 - EG18 MOISTURE SEPARATOR SUB ASSY

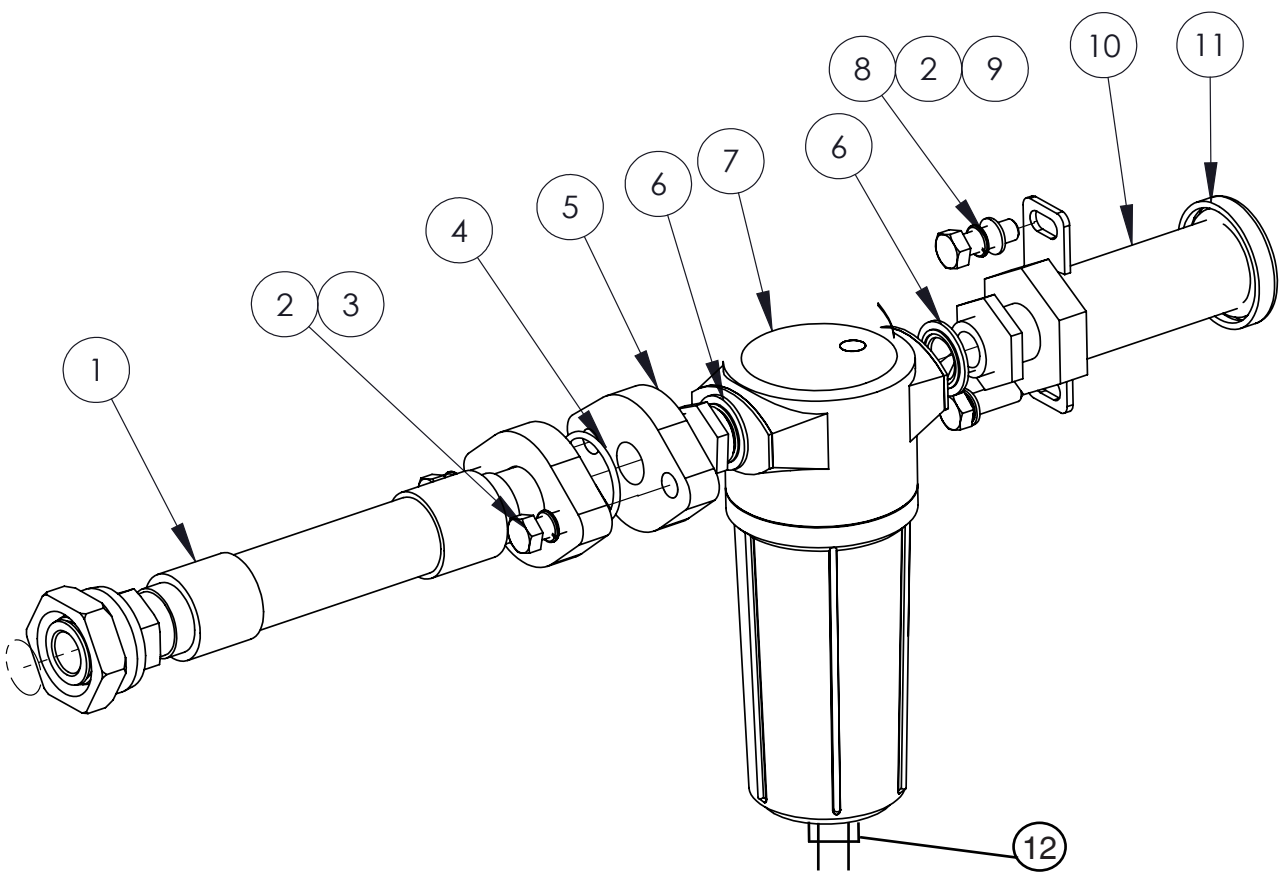

MOISTURE SEPARATOR SUB ASSY EG11 - EG 18

S.NO	PART NO.	DESCRIPTION	QTY.
1	015313383	MS Inlet Hose with flange	1
2	000996108	M8 spring washer	4
3	000906117	M8X30 Bolt	2
4	035400026	O - RING 37.5 x 3	1
5	015313170	MS Inlet Pipe	1
6	000959438	3/4" Dowty washer	2
7	B000305480003	Moisture separator MS 150	1
8	000906121	M8 X 50 bolt	2
9	000996008	M8 plain washer	2
10	015313350	MS outlet pipe	1
11	015313700	Bellows	1
12	000919226	Plastic tubing dia 6 x 1	0.89m

EG22 MOISTURE SEPARATOR SUB ASSY

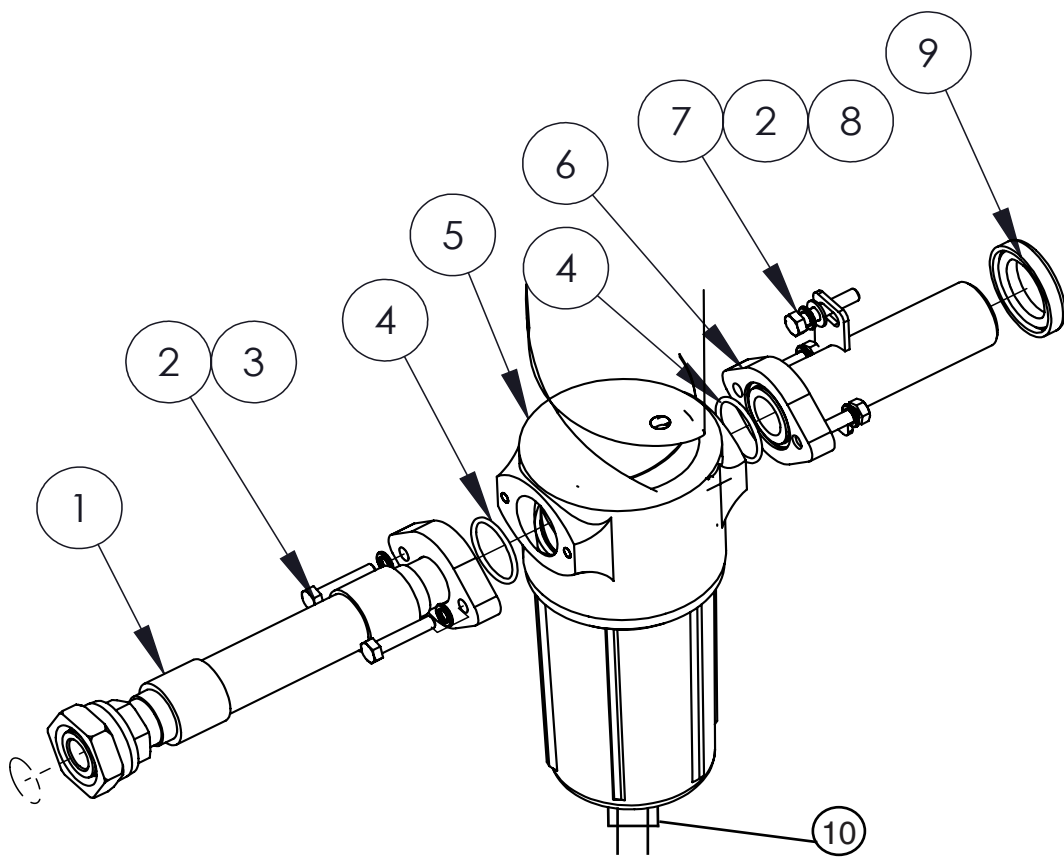

MOISTURE SEPARATOR SUB ASSY EG 22

S.NO	PART NO.	DESCRIPTION	QTY.
1	015313383	MS Inlet Hose with flange	1
2	000996108	M8 spring washer	6
3	000906117	M8X30 Bolt	4
4	035400026	O - RING 37.5 x 3	2
5	B000305480002	Moisture separator MS365	1
6	015313154	MS Outlet Pipe with flange	1
7	000906121	M8 X 50 bolt	2
8	000996008	M8 plain washer	2
9	015313700	Bellows	1
10	000919226	Plastic tubing dia 6 x 1	0.89m

BASE AND CANOPY ASSY

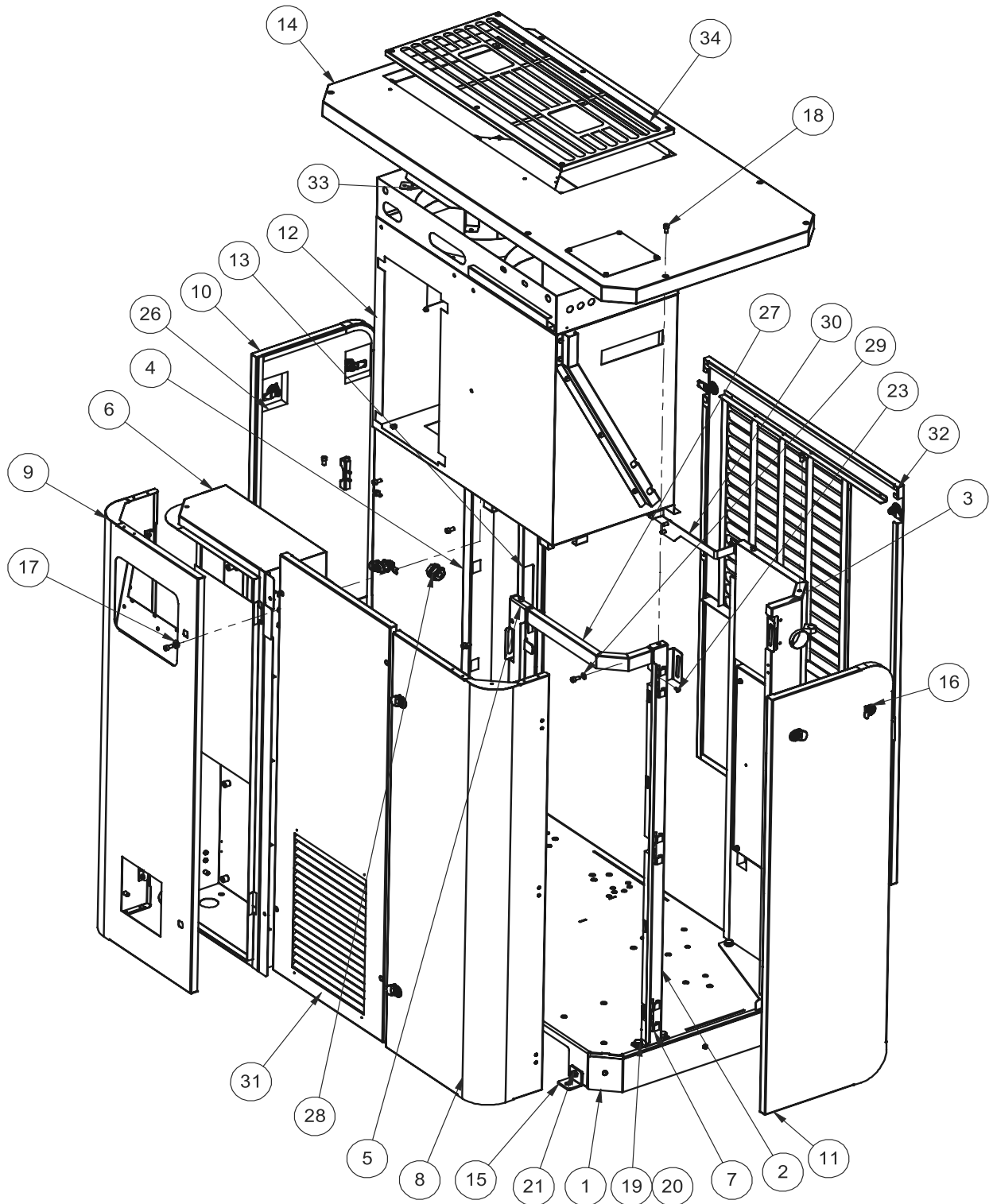

BASE AND CANOPY ASSY

S.NO	PART NO.	DESCRIPTION	QTY.	REMARKS
1	015312736	BASE ASSEMBLY	1	
2	015312739	FRONT PILLAR – TANK	1	
3	015313384	REAR PILLAR-BALL VALVE	1	
4	015312741	REAR PILLAR - MOTOR	1	
5	015312738	FRONT PILLAR - MIDDLE	1	
6	015312737	CONTROL PANEL ASSY	1	
7	B011604790005	HINGE - DOOR RH & LH	6	
8	015312747	DOOR RH	1	
9	015312746	DOOR LH	1	
10	015312743	SIDE COVER ASSY LH	1	
11	015312744	SIDE COVER ASSY RH	1	
12	015312750	COOLER BOX ASSY	1	
13	015402391	COOLER BOX MTG BKT 3 ASSY	1	
14	015312748	TOP ROOF ASSY	1	
15	015402419	L MOUNT BKT	4	
16	B15204790005	LOCK	12	
17	-	WASHER SPRING M8	4	
18	-	SOCKET HEAD CAP SCREW M8x16	23	
19	-	WASHER SPRING M12	14	
20	-	BOLT HEX. M12 x 30	14	
21	-	BOLT HEX. M10 x 20	5	
22	-	WASHER SPRING M10	1	
23	-	CSK Screw M6x13	12	
24	018402244	PANEL CAP DIA 50	1	
25	B15204790004	SERVICE DOOR KEY	1	
26	015314033	FOAM SET 50Hz & 60Hz	"1 SET"	
27	015312858	SUPPORT PLATE ASSY	1	
28	015312907	CONNECTOR ASSY 1/4	1	
29	-	PLAIN WASHER M8	2	
30	015403727	SHROUD SUPPORT PLATE - 1	1	
31	015312742	PANEL-FRONT	1	FOR W/O DRYER MODELS
	015313834	PANEL-FRONT	1	FOR WITH DRYER MODELS
32	015312745	REAR COVER 18-22	1	18 & 22Kw MODELS
	015312912	REAR COVER 11-15		11 & 15Kw MODELS
33	015311408	FAN DUCT PLATE ASSY	1	11 KW MODEL
34	015312768	FAN GUARD	1	ALL MODELS
35	B010406050001	RUBBER BEEDING	3.7m	CONTROL PANEL BOX
	B010406050001	RUBBER BEEDING	1.4 m	FRINT PILLAR TANK
	B010406050001	RUBBER BEEDING	1.4 m	FRONT PILLER MIDDLE
	B010406050001	RUBBER BEEDING	2.4 m	COOLER BOX
36	B010406050001	CLIP-ON GASKET	-	

AIREND ASSEMBLY -159 DD 25 HP - 100, 125 PSI, 30 HP- 100,125 & 150 PSI

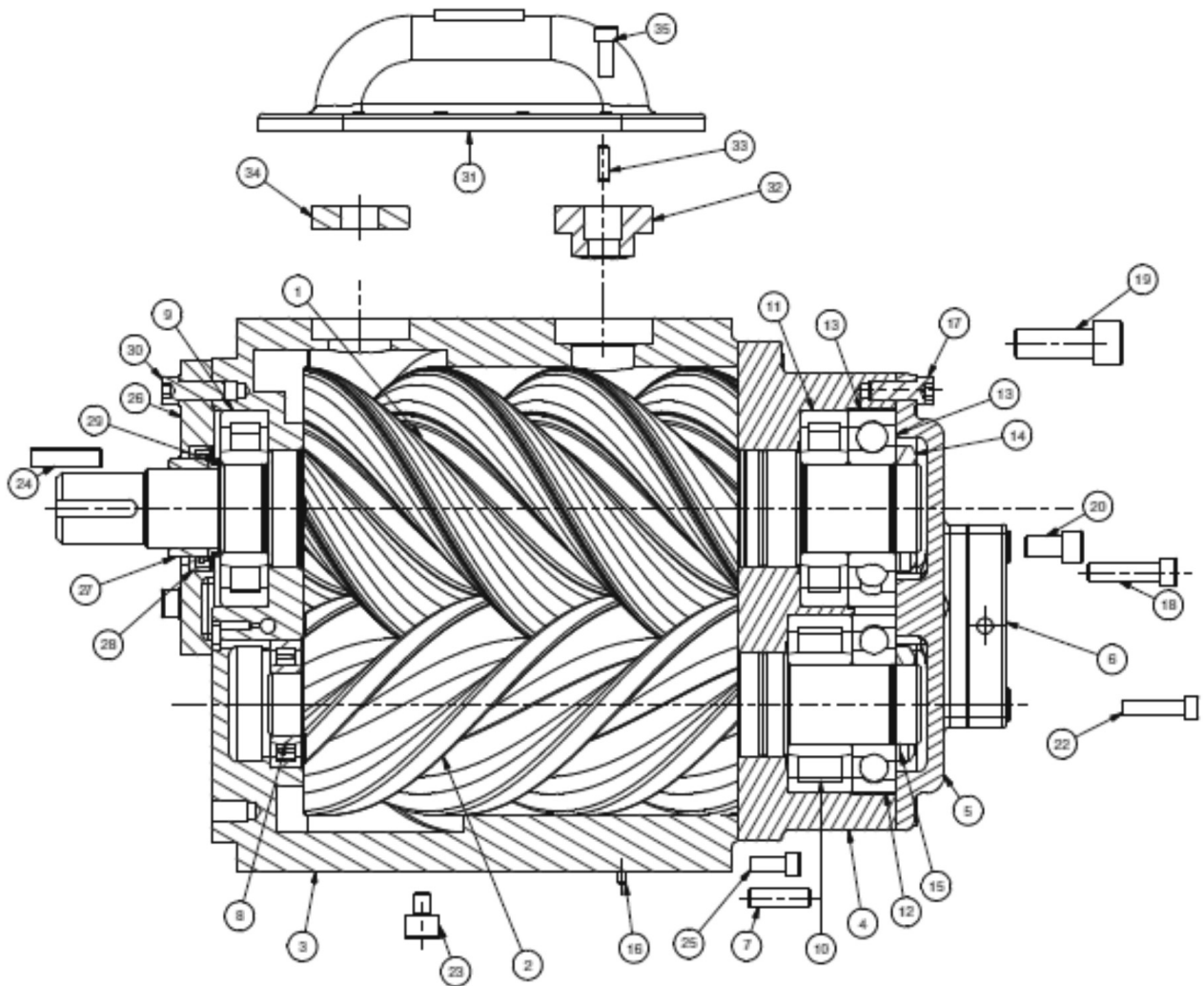

AIREND ASSEMBLY -159 DD 25 HP - 100, 125 PSI, 30 HP- 100,125 & 150 PSI

S.NO	PART NO.	DESCRIPTION	QTY.
1	01 33 3619 4	MALE ROTOR	1
2	01 33 3619 5	FEMALE ROTOR	1
3	99 03 0149 0	HOUSING, ROOTOR	1
4	01 33 3616 9	HOUSING, BEARING/DISCHARGE	1
5	01 33 3617 1	COVER, BEARING HOUSING	1
6	99 04 0111 0	COVER, DISCHARGE	1
7	22 041002 B	PIN DOWEL	2
8	00 090358 0	BEARING RADIAL SUCTION FEMALE	1
9	22 032064 F	BEARING RADIAL SUCTION MALE	1
10	22 032569 0	BEARING RADIAL DISCHARGE FEMALE	1
11	22 032064 F	BEARING C/ROLL DISCHARGE MALE	1
12	00 900343 7	BEARING ANG. CONT.DISCHARGE FEMALE	1
13	00 090343 8	BEARING ANG. CONT.DISCHARGE MALE	1
14	01 343617 7	LOCKNUT MALE	1
15	01 343617 8	LOCKNUT FEMALE	1
16	22 041038 A	PLUG HEX. SOCKET	9
17	00 098311 4	SCREW SOCKET HEAD CAP	11
18	00 098311 6	SCREW SOCKET HEAD CAP	2
19	00 098520 4	SCREW SOCKET HEAD CAP	4
20	00 098314 1	SCREW SOCKET HEAD CAP	4
21	22 04 1760 0	NAME PLATE	1
22	00 05 1952 0	RIVET DIA 2.5 X 4.5	2
23	01 34 3607 8	ORIFICE RETURN LINE	1
24	99 04 0119 0	KEY	1
25	00 09 8308 3	SCREW SOCKET HEAD CAP	2
26	01 33 3618 9	SEAL HOUSING	1
27	01 34 3625 6	INNER RING	1
28	01 34 3618 1	SEAL SHAFT	1
29	01 34 3625 5	SPACER - 159	1
30	00 09 8314 4	HEX SOCKET HEAD SCREW	5
31	99 03 0324 0	BLEED SIDE PLATE	1
32	99 04 0107 0	BLEED ORIFICE FOR E15-7.5	1
32	99 04 0106 0	BLEED ORIFICE FOR E18-10	1
33	99 04 0116 0	CYL. DOWEL PIN - BLEED	1
34	99 04 0147 0	SUCTION ORIFICE	1
35	00 09 8308 3	SCREW SOCKET HEAD CAP	12

AIREND ASSEMBLY -102 - GD

15HP & 20 HP - 100 TO 175 PSI, 25HP - 150 & 175 PSI, 30HP - 175 PSI

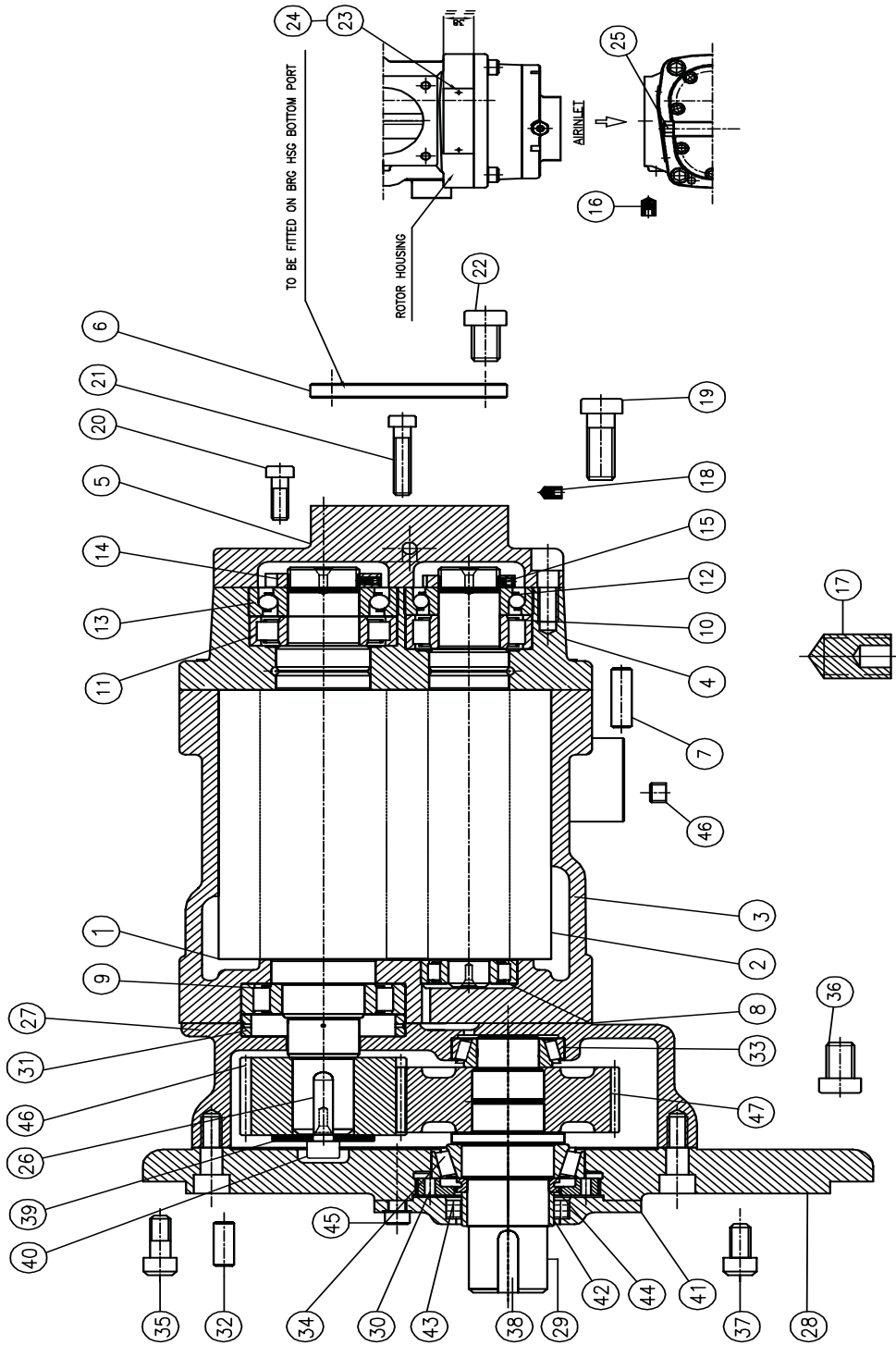

AIREND ASSEMBLY -102 - GD

15HP & 20 HP - 100 TO 175 PSI, 25HP - 150 & 175 PSI, 30HP - 175 PSI

S.NO	PART NO.	DESCRIPTION	QTY.
1	01 33 3608 9	MALE ROTOR	1
2	01 33 3609 0	FEMALE ROTOR	1
3	01 33 3606 7	HOUSING, ROTOR	1
4	01 33 3607 0	HOUSING, BEARING/DISCHARGE	1
5	01 33 3606 8	COVER, BEARING HOUSING	1
6	01 34 3607 4	COVER, DISCHARGE	1
7	22 04 1002 B	PIN DOWEL	2
8	00 09 0358 2	BEARING RADIAL SUCTION FEMALE	1
9	00 09 0358 1	BEARING RADIAL SUCTION MALE	1
10	00 09 0358 3	BEARING RADIAL DISCHARGE FEMALE	1
11	00 09 0358 0	BEARING C/ROLL DISCHARGE MALE	1
12	00 09 0340 5	BEARING ANG.CONT. DISCHARGE FEMALE	1
13	00 09 0340 6	BEARING ANG.CONT. DISCHARGE MALE	1
14	01 34 3607 5	LOCKNUT MALE	1
15	01 34 3607 6	LOCKNUT FEMALE	1
16	22 04 1038 A	PLUG HEX.SOCKET	1
17	22 04 1038 B	PLUG HEX.SOCKET	1
18	00 09 8774 0	SCREW HEX SOCKET HEAD GRUB	7
19	00 09 8314 4	SCREW SOCKET HEAD CAP	4
20	00 09 8308 4	SCREW SOCKET HEAD CAP	5
21	00 09 8308 9	SCREW SOCKET HEAD CAP	4
22	00 09 8314 1	SCREW SOCKET HEAD CAP	4
23	22 04 1760 0	NAME PLATE	1
24	00 05 1952 0	RIVET DIA 2.5 X 4.5	2
25	01 34 3607 8	ORIFICE RETURN LINE	1
26	01 34 3609 2	KEY	1
27	01 33 3611 0	HOUSING GEAR	1
28	01 33 3611 1	GEAR HOUSING COVER (FLANGE MTG)	1
29	01 33 3641 0	INPUT SHAFT	1
30	01 34 3613 2	WIND - BACK INPUT SHAFT	1
31	01 34 3613 3	LOCATING RING	1
32	22 04 1002 B	PIN DOWEL	2
33	00 00 03 156	TAPER ROLLER BEARING (FRONT)	1
34	00 09 03 155	TAPER ROLLER BEARING (REAR)	1
35	00 09 8511 4	HEX SOCKET HEAD SCREW	12
36	00 09 8314 1	HEX SOCKET HEAD SCREW	4

AIREND ASSEMBLY -102 - GD

15HP & 20 HP - 100 TO 175 PSI, 25HP - 150 & 175 PSI, 30HP - 175 PSI

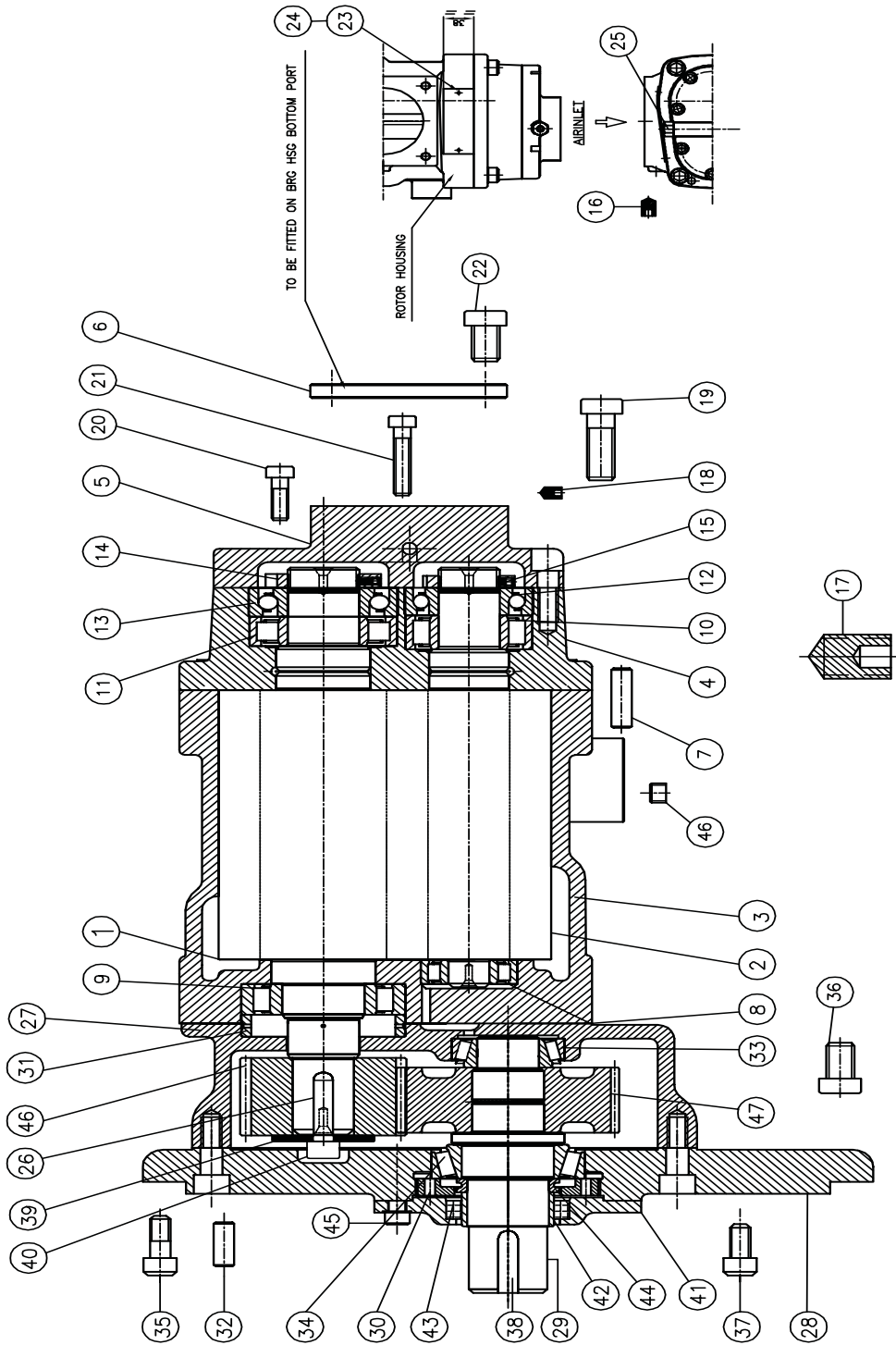

AIREND ASSEMBLY -102 - GD**15HP & 20 HP - 100 TO 175 PSI, 25HP - 150 & 175 PSI, 30HP - 175 PSI**

S.NO	PART NO.	DESCRIPTION	QTY.
37	00 09 8308 4	HEX SOCKET HEAD SCREW	1
38	01 34 3609 2	KEY	1
39	99 04 0034 0	RETAINER, GEAR	1
40	00 09 8311 3	HEX SOCKET HEAD SCREW	1
41	01 33 3640 9	SEAL HOUSING	1
42	01 34 3608 8	SLEEVE WEAR	1
43	01 34 3640 8	SEAL SHAFT	1
44	01 34 3608 7	SPACER - 102	1
45	00 09 8308 4	HEX SOCKET HEAD SCREW	5

RDS KIT

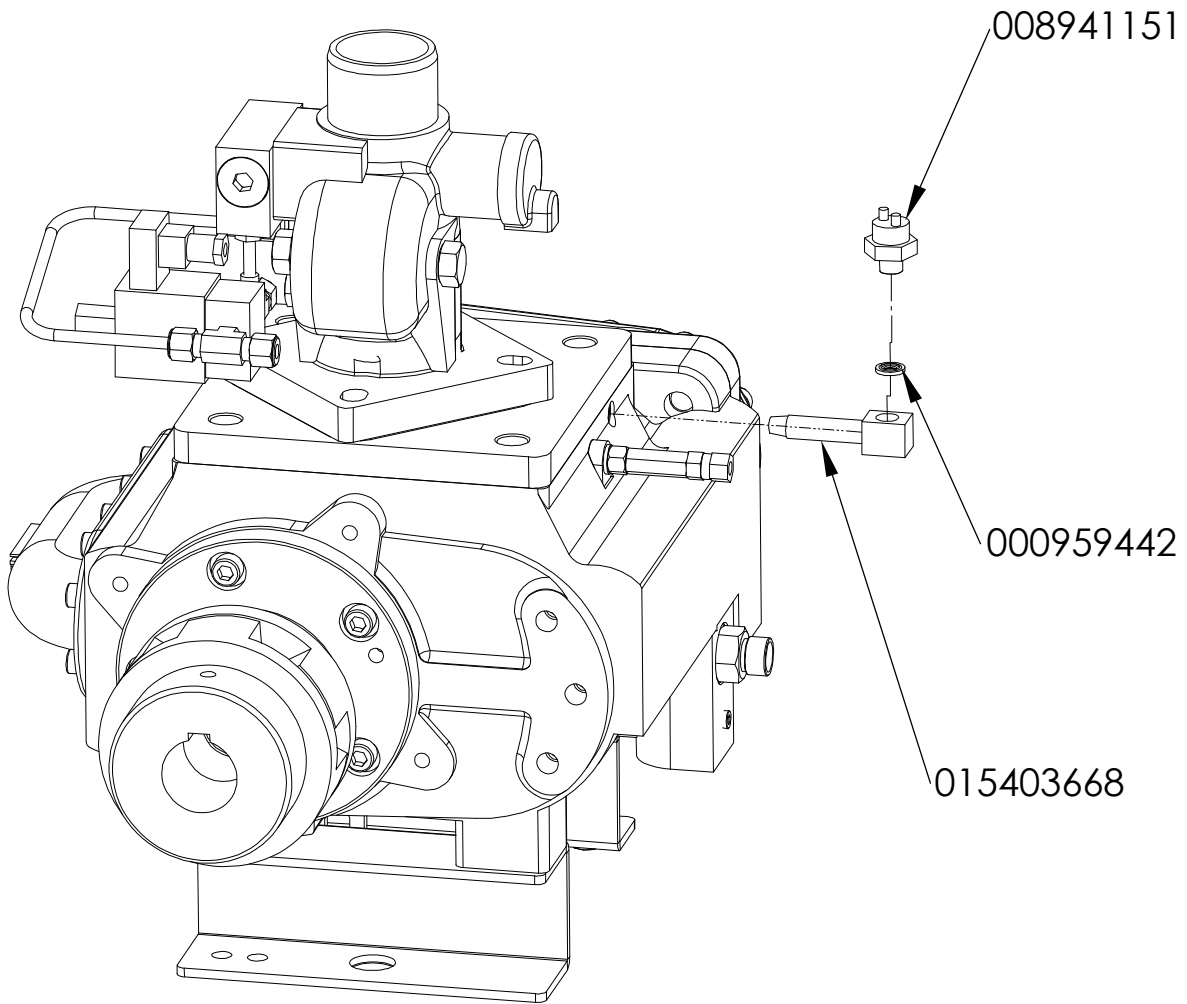

S.NO	PART NO.	DESCRIPTION	QTY.
1	008941151	SWITCH REVERSE ROTATION	1
2	000959442	M14 BONDED SEAL WASHER	1
3	015403668	RDS MOUNTING CONNECTOR	1

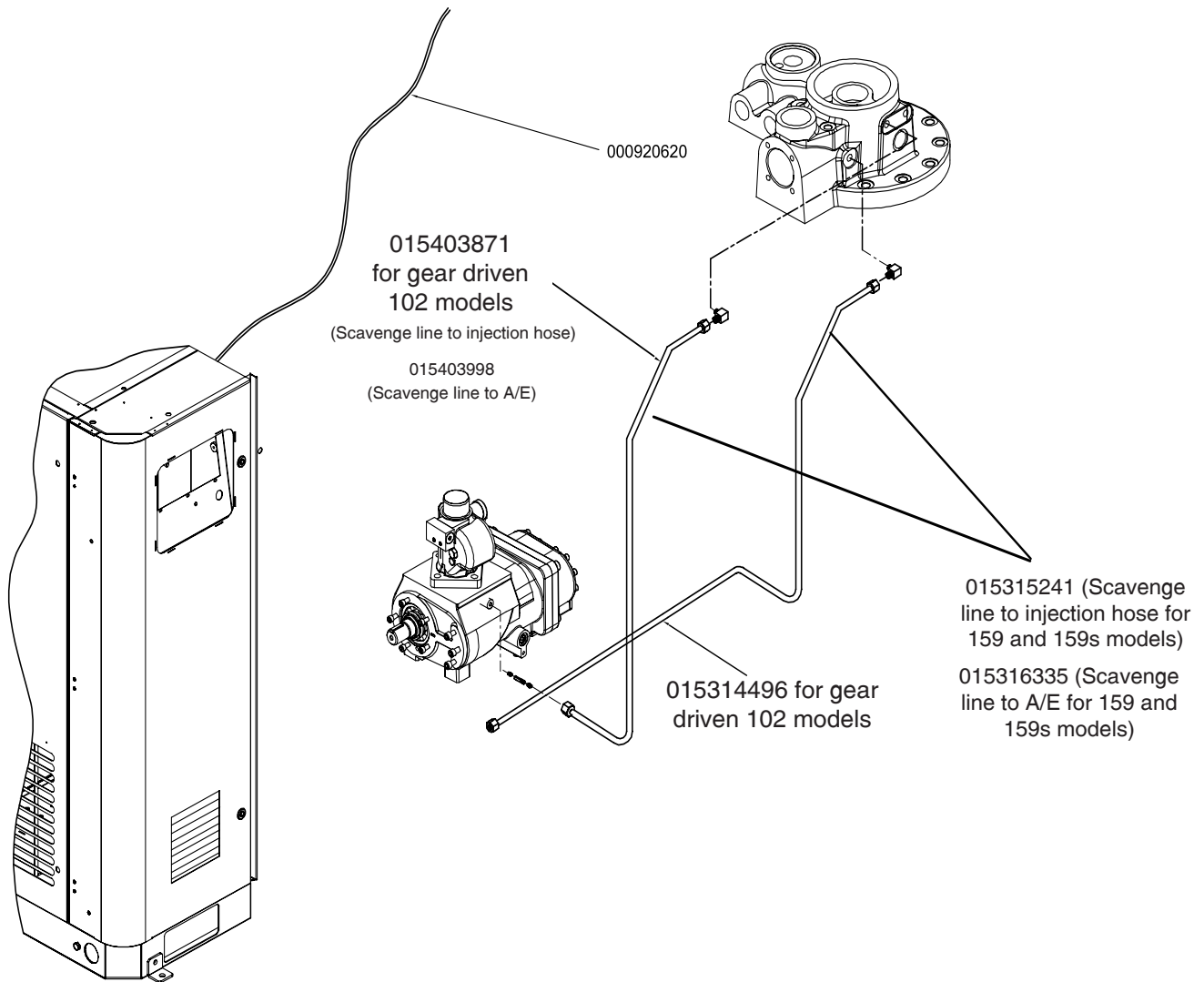

PULSE LINE, OIL RETURN LINE ASSY. DETAILS

HOSE PARTS LIST

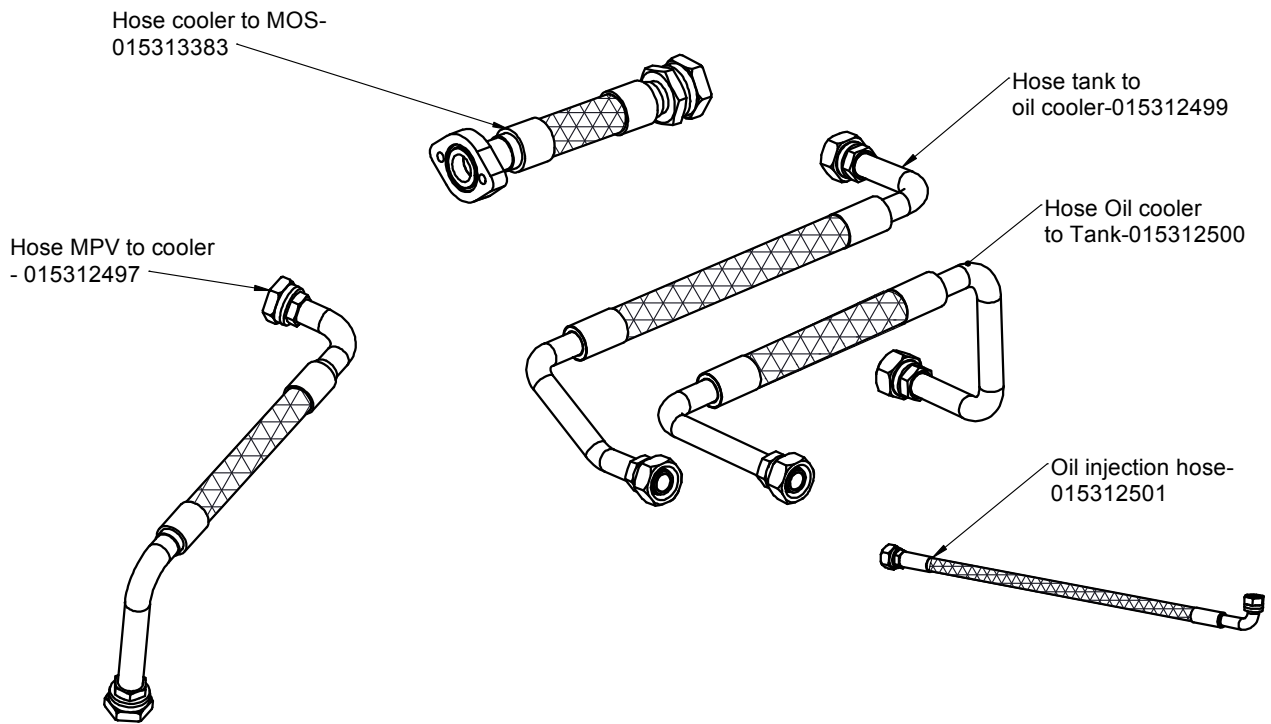

**HOSE PARTS LIST
FOR STANDARD VERSION AND STD + VFD VERSION**

S.NO	PART NO.	DESCRIPTION
1	012477899	HOSE MPV TO COOLER KIT
2	012477909	HOSE MOS TO BALL VALVE KIT
3	012448399	HOSE TANK TO COOLER KIT
4	012448499	HOSE COOLER TO TANK KIT
5	012448599	HOSE OIL INJECTION KIT

SPARE KIT DETAILS FOR E11 (15 HP) - E22 (30 HP)

S.NO	DESCRIPTION	PART NUMBERS	QTY
1	INTAKE VALVE KIT	B009401070007	1
2	BLOWN DOWN VALVE KIT	B015401070004	1
3	DRIVE COUPLING ELEMENT 18kW TO 22kW	B011201170002	1
4	DRIVE COUPLING ELEMENT 11kW TO 15kW	B011201170003	1
5	O-RING AND GASKET KIT 159 AIREND	012447599	1
6	O-RING AND GASKET KIT 102 AIREND	012447699	1
7	PULSE LINE RETURN LINE, CORRESPONDING FERRULE AND SLEEVE KIT - 102 AIREND	012474809	1
8	PULSE LINE RETURN LINE, CORRESPONDING FERRULE AND SLEEVE KIT - 159 AIREND	012474819	1
9	MINIMUM PRESSURE VALVE KIT	B009301070014	1
10	ADAPTOR 1/4"	000920504	1
11	HOSE 1M LENGTH	000919228	1
12	REPAIR KIT I / V HPKG 50	B015401070002	1
13	SOLENOID COIL KIT I / V HPKG 50	BO15401070001	1

Consumables Kit For 102 MODELS (EG11-EG15-100,125,150,175),(EG18-150,175),(EG22-175) Kit Part number 012474239

S.NO	DESCRIPTION	PART NUMBERS	QTY
1	OIL FILTER ELEMENT	B004800770001	4
2	AIRFILTER ELEMENT	B005700770004	2
3	AIR OIL SEPARATOR SPINON	B006700770010	1
4	PREFILTER	015400889	4

Consumables Kit For 159 MODELS (EG18-100,125),(EG22-100,125,150) Kit Part number 012474249

S.NO	DESCRIPTION	PART NUMBERS	QTY
1	OIL FILTER ELEMENT-75 LPM	B004800770001	4
2	AIRFILTER ELEMENT	B005700770005	2
3	AIR OIL SEPARATOR SPINON	B006700770010	1
4	PREFILTER	015400889	4

S.NO	INSURANCE KIT PART NO	MODEL
1	012474199	EG18-100,EG18-125 psi
2	012474209	EG18-150,EG18-175 psi
3	012474189	EG11-EG15 (100,125,150,175 psi)
4	012474219	EG22-100,125,150 psi
5	012474229	EG22-175 psi

S.NO	DESCRIPTION	PART NO	MODEL
1	Pulse line kit	012473739	(EG11-EG15-100,125,150,175),(EG18-150,175),(EG22-175)
2	Pulse line kit	012473749	(EG18-100,125),(EG22-100,125,150)
3	O ring & Gasket kit	012447699	(EG11-EG15-100,125,150,175),(EG18-150,175),(EG22-175)
4	O ring & Gasket kit	012447599	(EG18-100,125),(EG22-100,125,150)

SS Tube with fittings Kit For 102 MODELS (EG11-EG15-100,125,150,175),(EG18-150,175),(EG22-175) Kit Part number 012474809

S.NO	DESCRIPTION	PART NUMBERS	QTY
1	000959916	ELBOW 1/8 TO 6mm OD	1
2	015306425	PIPE SET- AIR PIPE	1
3	015402615	PIPE -BLOWN DOWN OIL PIPE15kW	1
4	015403609	ELBOW; TMS; 1/4	2
5	015403610	TEE; BRANCH; TM; 1/4	1
6	015403616	ST FITTING 1/8 TO 6MM OD	1

SS Tube with fittings Kit For 159 MODELS (EG18-100,125),(EG22-100,125,150) Kit Part number 012474819

S.NO	DESCRIPTION	PART NUMBERS	QTY
1	000959916	ELBOW 1/8 TO 6mm OD	1
2	015311907	PIPE SET - F2 - US	1
3	015403609	ELBOW; TMS; 1/4	2
4	015403610	TEE; BRANCH; TM; 1/4	1
5	015403616	ST FITTING 1/8 TO 6MM OD	1

Cooler Prefilter Part Numbers for Accessories

S.NO	DESCRIPTION	PART NUMBERS	QTY
1	A010517	COOLER PRE FILTER ASSEMBLY-F2	1No. per M/c

Spares Cooler Prefilter Element

S.NO	DESCRIPTION	PART NUMBERS	QTY
1	B016306250002	PRE FILTER ELEMENT - COOLER F2	1No.

Insurance Kit Details

EG 11 to EG 22 (15 HP to 30 HP) - 60Hz

		Models	11,15 C & CV ALL MODELS	18 C & CV 100,125 PSI	18 C & CV 150,175 PSI	22 C & CV 100,125, 150 PSI	22 C & CV 175 PSI
		Kit No ↓	012478919	012478929	012478939	012478949	012478959
S.No	PART DESCRIPTION	PART NUMBER					
1	Intake valve kit	B009401070007	<input checked="" type="checkbox"/>	<input checked="" type="checkbox"/>	<input checked="" type="checkbox"/>	<input checked="" type="checkbox"/>	<input checked="" type="checkbox"/>
2	Blowdown valve kit	B015401070004	<input checked="" type="checkbox"/>	<input checked="" type="checkbox"/>	<input checked="" type="checkbox"/>	<input checked="" type="checkbox"/>	<input checked="" type="checkbox"/>
3	Drive coupling element 11kW TO 15kW	B011201170003	<input checked="" type="checkbox"/>	<input checked="" type="checkbox"/>	<input checked="" type="checkbox"/>	<input checked="" type="checkbox"/>	<input checked="" type="checkbox"/>
4	Drive coupling element 18kW TO 22kW	B011201170002	<input checked="" type="checkbox"/>	<input checked="" type="checkbox"/>	<input checked="" type="checkbox"/>	<input checked="" type="checkbox"/>	<input checked="" type="checkbox"/>
5	O-ring and gasket kit 159 Airend	012447599	<input checked="" type="checkbox"/>	<input checked="" type="checkbox"/>	<input checked="" type="checkbox"/>	<input checked="" type="checkbox"/>	<input checked="" type="checkbox"/>
6	O-Ring and gasket kit 102 Airend	012447699	<input checked="" type="checkbox"/>	<input checked="" type="checkbox"/>	<input checked="" type="checkbox"/>	<input checked="" type="checkbox"/>	<input checked="" type="checkbox"/>
7	Pulse line, return line, Corresponding Ferrule and Sleeve kit - 102 Airend	012474809	<input checked="" type="checkbox"/>	<input checked="" type="checkbox"/>	<input checked="" type="checkbox"/>	<input checked="" type="checkbox"/>	<input checked="" type="checkbox"/>
8	Pulse line, return line, Corresponding Ferrule and Sleeve kit - 159 Airend	012474819	<input checked="" type="checkbox"/>	<input checked="" type="checkbox"/>	<input checked="" type="checkbox"/>	<input checked="" type="checkbox"/>	<input checked="" type="checkbox"/>
9	Solenoid valve	B015401070004	<input checked="" type="checkbox"/>	<input checked="" type="checkbox"/>	<input checked="" type="checkbox"/>	<input checked="" type="checkbox"/>	<input checked="" type="checkbox"/>
12	Minimum Pressure Valve Kit	B009301070014	<input checked="" type="checkbox"/>	<input checked="" type="checkbox"/>	<input checked="" type="checkbox"/>	<input checked="" type="checkbox"/>	<input checked="" type="checkbox"/>
13	Temperature sensor	00897902m	<input checked="" type="checkbox"/>	<input checked="" type="checkbox"/>	<input checked="" type="checkbox"/>	<input checked="" type="checkbox"/>	<input checked="" type="checkbox"/>
14	Pressure Transmitter	00897902n	<input checked="" type="checkbox"/>	<input checked="" type="checkbox"/>	<input checked="" type="checkbox"/>	<input checked="" type="checkbox"/>	<input checked="" type="checkbox"/>
15	Oil Level Sight Glass	015306521	<input checked="" type="checkbox"/>	<input checked="" type="checkbox"/>	<input checked="" type="checkbox"/>	<input checked="" type="checkbox"/>	<input checked="" type="checkbox"/>
16	Shaft Seal - Bleed	013436181	<input checked="" type="checkbox"/>	<input checked="" type="checkbox"/>	<input checked="" type="checkbox"/>	<input checked="" type="checkbox"/>	<input checked="" type="checkbox"/>
17	Shaft Seal - Axis 102	013436408	<input checked="" type="checkbox"/>	<input checked="" type="checkbox"/>	<input checked="" type="checkbox"/>	<input checked="" type="checkbox"/>	<input checked="" type="checkbox"/>
18	Wear Sleeve - Bleed	013436255	<input checked="" type="checkbox"/>	<input checked="" type="checkbox"/>	<input checked="" type="checkbox"/>	<input checked="" type="checkbox"/>	<input checked="" type="checkbox"/>
19	Wear Sleeve - Axis 102	013436088	<input checked="" type="checkbox"/>	<input checked="" type="checkbox"/>	<input checked="" type="checkbox"/>	<input checked="" type="checkbox"/>	<input checked="" type="checkbox"/>
20	Inner Ring - Bleed	013436256	<input checked="" type="checkbox"/>	<input checked="" type="checkbox"/>	<input checked="" type="checkbox"/>	<input checked="" type="checkbox"/>	<input checked="" type="checkbox"/>
21	Inner Ring - Axis 102	013436087	<input checked="" type="checkbox"/>	<input checked="" type="checkbox"/>	<input checked="" type="checkbox"/>	<input checked="" type="checkbox"/>	<input checked="" type="checkbox"/>

* * Parts not included in Insurance kit

C : Standard version

CV : Standard + Variable Frequency Drive

VFD SETTING PROCEDURE

Brief introduction about VFD in Global Series Compressor.

In the VFD model compressors, the Variable Frequency Drive (VFD) is integrated with the compressor. i.e. the main motor is controlled through VFD instead of star delta starter.

Hardware (wiring) details

The wiring integrations with VFD and control panel/controller are shown in the drawing and the purpose of each connection is given below

1. 3 Phase connection to VFD:

The input side phase sequence is critical for the fan direction of rotation (during installation the fan direction needs to be checked and if required change the phase sequence). However motor phase sequence is controlled by VFD.

2. Motor Connection:

It is wired for required phase sequence w r t compressor requirement, and do not attempt to change.

3. Start Command to VFD:

Start/Stop command given to the VFD from Controller to rotate/stop the main motor.

4. Run Feedback signal:

After reaching 40% of speed VFD send a run feedback signal to controller to switch on solenoid valve to start loading process.

5. Trip command from VFD:

During any abnormalities in VFD drive a trip signal is sent to controller to stop the compressor. (To troubleshoot refer VFD manual)

6. Pressure feedback signal:

Delivery pressure feedback signal is given from controller (analogue output CH1) to VFD as analogue voltage signal ranging 1-5 V, which in turn controls the motor speed.

NOTE: Ensure dip switch in VFD (right behind the display) is set in voltage mode.

7. RS485 Communication:

RS 485 communication medium is established between VFD and Controller to read/write the parameters Voltage, Current, Power, Frequency, and analog scale setting.

All the above connections are factory wired and it is only required to connect the incoming supply to the compressor with right wire size & incoming protection fuse (as per compressor manual)

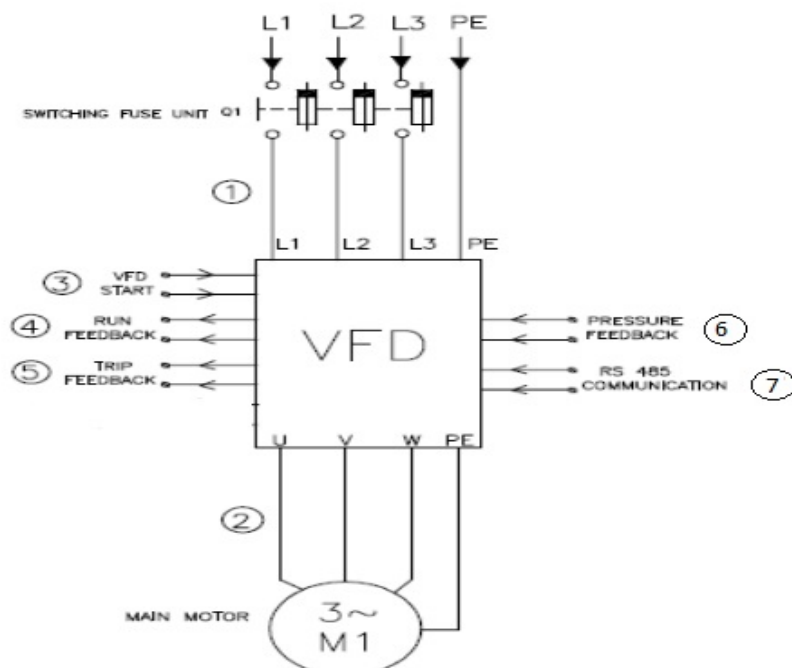

Software details (programming details)

Based on the compressor rating VFD parameter's are pre programmed in Setup1 Location. (The setting details are given in Annexure 1) & in the compressor controller.

During installation & commissioning the PI can be tuned at site to have smooth speed control according to the customer demand. Except PI settings in the controller no other setting is required to change, and similarly in VFD all settings are pre programmed and not required to change any of the settings.

During operation the customer can change the load pressure set point according to his requirement.

The Following parameters are important for the correct Drive operation.

- * Right analog output feedback from controller to VFD. (1V corresponds to AO scaling low reference and 5V corresponds to AO scaling high reference)
- * The AO High and low reference scaling settings are done in factory setting menu in the Neuron II controller and can be viewed in View parameters in the NII controller, the corresponding low ref and high ref setting to be verified in drive parameters 614 and 615 respectively.
- * Ensure dip switch in VFD (right behind the display) is set in voltage mode.
- * In the Neuron II controller the Required pressure to be set in the load pr setting. The unload pressure is always 7 psi above the load pressure (in the VFD enable machines the unload pr set point is irrelevant)
- * Enter motor name plate details in VSD settings (voltage, current (I max value-SF current), power, frequency, and RPM)
- * The parameters 614 and 615 in the VFD is edited thru controller (do not attempt to change) and this value should match the AO scaling in the controller
- * The PI parameters to be adjusted at site for effective tuning of to have the smooth speed control to meet exact customer requirement

For more details about VFD parameters and trouble shooting refer the VFD manual send along with the compressor.

Operation:

Start command is given from Controller to VFD there by compressor motor starts rotating in required direction.

Once after receiving the start command VFD accelerate compressor motor to 40% speed (minimum speed setting in controller) and after ensuring the run feedback signal from VFD and reaching of 40% speed controller actuates the solenoid valve to start the loading process and the VFD increases motor speed from 40% to 100% (max speed setting in the controller).

Until the Target pressure is reached the VFD delivers 100% speed. Once the Target pressure is reached and the demand is low, then the speed comes down to maintain the set pressure it varies based on the demand from 40 to 100% speed.(w r to pressure range the speed limits changes)

If the speed reaches 40% of rated still the demand is low then the pressure increases and reached load pressure + 7 psi, the compressor goes to unload mode & compressor now runs at unload speed.

If the pressure reduces down and reaches the load point of the controller then compressor starts loading and the speed increases from 40% to maintain the set pressure.

If the machine runs in unload for more than stand by time set in the controller the compressor stops and goes to standby mode and wait for pressure reaches the load set point in the controller, then the compressor starts as per the start sequence.

If the drive is not responding to quick pressure changes (drop in set pressure) or drive responds very fast to pressure changes (continuous increase and decrease in speed to maintain the set pressure), The P and I settings to be adjusted in the NII controller**

** One time fine tuning is recommended during installation by expertise person.

In the case customer not preferred speed change w r to pressure, and wants to operate in fixed speed, he can set optimum speed enable (The option is available in Operator setting), in this case the compressor will run always at optimum speed during load and during unload the compressor will run at unload speed.

NOTE: The max speed , min speed, optimum speed, unload speed are factory set and do not attempt to change, the set speed details can be viewed thru operator menu

Trouble Shooting

	Fault Description	Details to be checked
1	The motor runs at full speed or low speed (no speed change wrt pressure)	The PI settings in the controller to be reduced to have the speed response for the pressure variation. The compressor does not develop the required pressure (under rating of compressor) always run at max speed of the motor. Check the Controller A/O scaling value (viewed in operator menu) wrt to VFD parameter 614,615 Check unload is enabled in the controller Check optimum speed setting is enabled
2	The motor speed changes frequently and make noise (acceleration and DE-acceleration)	The PI setting is too short and it continuously give feedback to change the speed of the motor, very high response to pressure variation and in this case the PI values to be increased to have smooth speed change over.
3	The motor runs at low speed continuously(30Hz)	Compressor run in unload mode The Air demand is less and the standby time set is more than 3 minutes.
4	The compressor minimum and maximum speed is not as per minimum speed and max speed limits setting in the controller	Check AO scaling values in the controller (operator menu view) and VFD parameter 614 and 615 are same
5	Motor Not starting	Check VFD gets start command and VFD display should show Ramping or Running. Check for any Trip Message in the VFD. Check the ON status LED in the VFD glows if not press Auto on button in the VFD and ensure the ON LED glows. Check the pressure is more than load pressure and compressor in standby mode.
6	Compressor not goes to load mode	Check the run feed back signal from VFD, Check the controller is giving load command Check the solenoid valve is getting supply and energized
7	Compressor trips from VFD and controller displays as VFD fault	Check the motor current taken is more than name plate value Check the VFD parameter is correct, Check the VFD trip history/ details of trip and do the required corrections as per the VFD trouble shooting details

FAQ

What is Target pressure?

Its a set load pressure which VFD needs to maintained by varying the speed of the compressor motor. If the demand is low the speed reduces and try to maintain the pressure and still demand is low, the pressure increases and it reaches load pressure + 7 psi the compressor goes to unload and during unload the compressor runs at unload speed.

What is the significance of P & I settings in controller?

The Change in pressure wrt to time is not linear in all the cases, but the rate of change in pressure depends on receiver and pipeline capacity of the particular customer, if the customer is having higher storage capacity the time available for speed correction is high, in the other side there is lower storage capacity the time to response the pressure requirement is also less, in this case the P & I setting to be adjusted at site for smooth speed change over. It is recommended one time fine tuning is required at site and the settings can be adjusted thru controller.

Why the direction of rotation is to be verified in VFD output?

The VFD output gives clock wise rotation always irrespective of the input connection to the VFD In the case the compressor to be run in counter clock wise the motor connection from VFD output to be reversed. (Refer the Circuit right direction of rotation)

What is the meaning of main motor Overload trip in the controller?

The VFD trip is connected to the controller in the case of main motor trip display in controller refer the VFD trip information and verify the type of trip and do the corrections as per the manual

What is the significance of AO scale setting in the controller?

The AO scaling is referring to 1V corresponds to min speed and 5V corresponds to max speed, based on this scaling range and Analogue input reference VFD calculates the required speed/frequency at which the compressor motor need to run. The AO scaling values in the controller settings and in the drive parameter 614,615 need to be same.

What is the significance of Max speed and min speed settings in the controller?

This gives limitation on Max/Min speed for selected compressor model and this limitation will change between compressor models. This setting must not exceed the AO scaling range.

What is the significance of optimum speed setting in the controller?

If the compressor needs to operate in fixed speed the optimum speed to be enabled in the operator setting, In the case of optimum speed enabled the compressor will run at optimum speed during load and run at unload speed during unload. This facility is available to give the flexibility to the customer if the compressed air circuit have more than one VFD machine and one machine is enough for speed control.

The optimum speed setting to be done in between the range of min and max speed setting

What is the significance of unload speed setting in the controller?

The unload speed is nothing but what speed the compressor has to run during unload. This setting to be in the range of min and max speed and less than optimum speed.

Annexure 1

ID	Name	Setup 1
1	Language	English
2	Motor Speed Unit	RPM
10	Active Set-up	Set-up 1
20	Display Line 1.1 Small	Motor Voltage
21	Display Line 1.2 Small	Motor current
22	Display Line 1.3 Small	Speed [RPM]
23	Display Line 2 Large	Analog Input 53
24	Display Line 3 Large	Frequency
40	[Hand on] Key on LCP	Disabled
41	[Off] Key on LCP	Disabled
42	[Auto on] Key on LCP	Enabled
43	[Reset] Key on LCP	Enabled
100	Configuration Mode	Speed open loop
101	Motor Control Principle	VVC+
104	Overload Mode	Normal torque
106	Clockwise Direction	Normal
120	Motor Power [kW]	Motor name plate
122	Motor Voltage	Motor name plate
123	Motor Frequency	Motor name plate
124	Motor Current	Motor name plate * SF
125	Motor Nominal Speed	Motor name plate
139	Motor Poles	Motor name plate
190	Motor Thermal Protection	ETR Trip1
191	Motor External Fan	Yes
300	Reference Range	Min - Max
301	Reference/Feedback Unit	RPM
302	Minimum Reference	900
303	Maximum Reference	2400
304	Reference Function	Sum
310-[0]	Preset Reference	0
313	Reference Site	Remote
315	Reference Resource 1	Analog Input 53
316	Reference Resource 2	No Function
317	Reference Resource 3	No Function
340	Ramp 1 Type	Linear
341	Ramp 1 Ramp Up Time	Refer Note #
342	Ramp 1 Ramp Down Time	
410	Motor Speed Direction	Clockwise
411	Motor Speed Low Limit [RPM]	900
413	Motor Speed High Limit [RPM]	2400
419	Max Output Frequency	80
512	Terminal 27 Digital Input	Coast inverse
540	Relay->Option relay 7-> Function relay	Running
540	Relay->Option relay 8-> Function relay	Alarm
610	Terminal 53 Low Voltage	1

ID	Name	Setup 1
611	Terminal 53 High Voltage	5
614	Terminal 53 Low Ref./Feedb. Value	*** (Edit from NII Controller)
615	Terminal 53 High Ref./Feedb. Value	*** (Edit from NII Controller)
830	Protocol	Modbus RTU
832	FC Port Baud rate	9600
833	Parity/Stop bits	No Parity,1 Stop bit
843-[0]	PCD read Configuration	(1603) – Status word
844-[1]	PCD read Configuration	(1605) – Main Actual Value ...
845-[2]	PCD read Configuration	(1612) – Motor Voltage
846-[3]	PCD read Configuration	(1613) – Frequency
847-[4]	PCD read Configuration	(1614) – Motor Current
848-[5]	PCD read Configuration	(1614) – Motor Current
849-[6]	PCD read Configuration	(1610) – Power KW
850-[7]	PCD read Configuration	(1610) – Power KW
851-[8]	PCD read Configuration	(1502) – Kwh Counter
852-[9]	PCD read Configuration	(1502) – Kwh Counter
853-[10]	PCD read Configuration	(1501) – Running Hours
854-[11]	PCD read Configuration	(1501) – Running Hours
855-[12]	PCD read Configuration	(1601) – Reference [Unit]
856-[13]	PCD read Configuration	(1601) – Reference [Unit]
857-[14]	PCD read Configuration	(1617) – Speed [RPM]
858-[15]	PCD read Configuration	(1617) – Speed [RPM]
859-[16]	PCD read Configuration	(1615) – Frequency [%]

NOTE: # Do the Ramp up time (341) and Ramp down time (342) settings as follows

Motor KW	Ramp Up time	Ramp Down time
11 KW to 45 KW	25sec	15 sec
55 KW and 75 KW	30 sec	20 sec
160 KW	30 sec	30 sec

Compressor controller setting in Operator menu VFD settings.

Item	Min	Max	Default	Unit
Optimum Speed	on/off	on/off	off	
P-Gain	0	50000	100	
I-Gain	0	5000	100	
I-Time	0	200	10	
Max.Speed	Factory setting can be viewed			RPM
Min.Speed				RPM
Optimum Speed				RPM
UL Speed				RPM
High (5V)				RPM
Low (1V)				RPM

The details given is for reference only, the settings are done at factory no need to do the setting at customer place. (except P,I, Integral time at the time of installation)

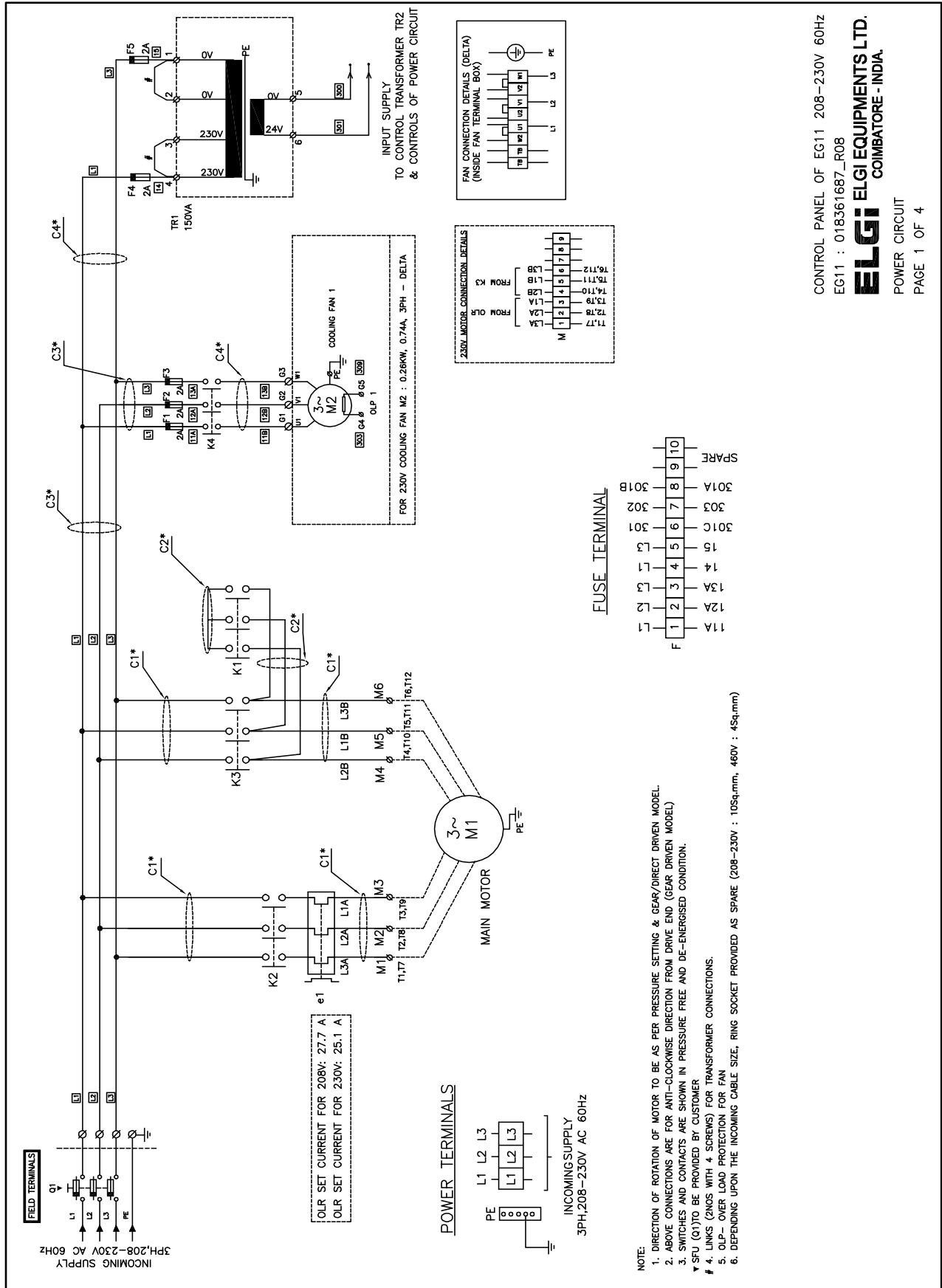

CONTROL PANEL OF EG11 208-230V 60Hz
EG11 : 018361687_R08

ELGI ELGI EQUIPMENTS LTD.
COIMBATORE - INDIA.

POWER CIRCUIT
PAGE 1 OF 4

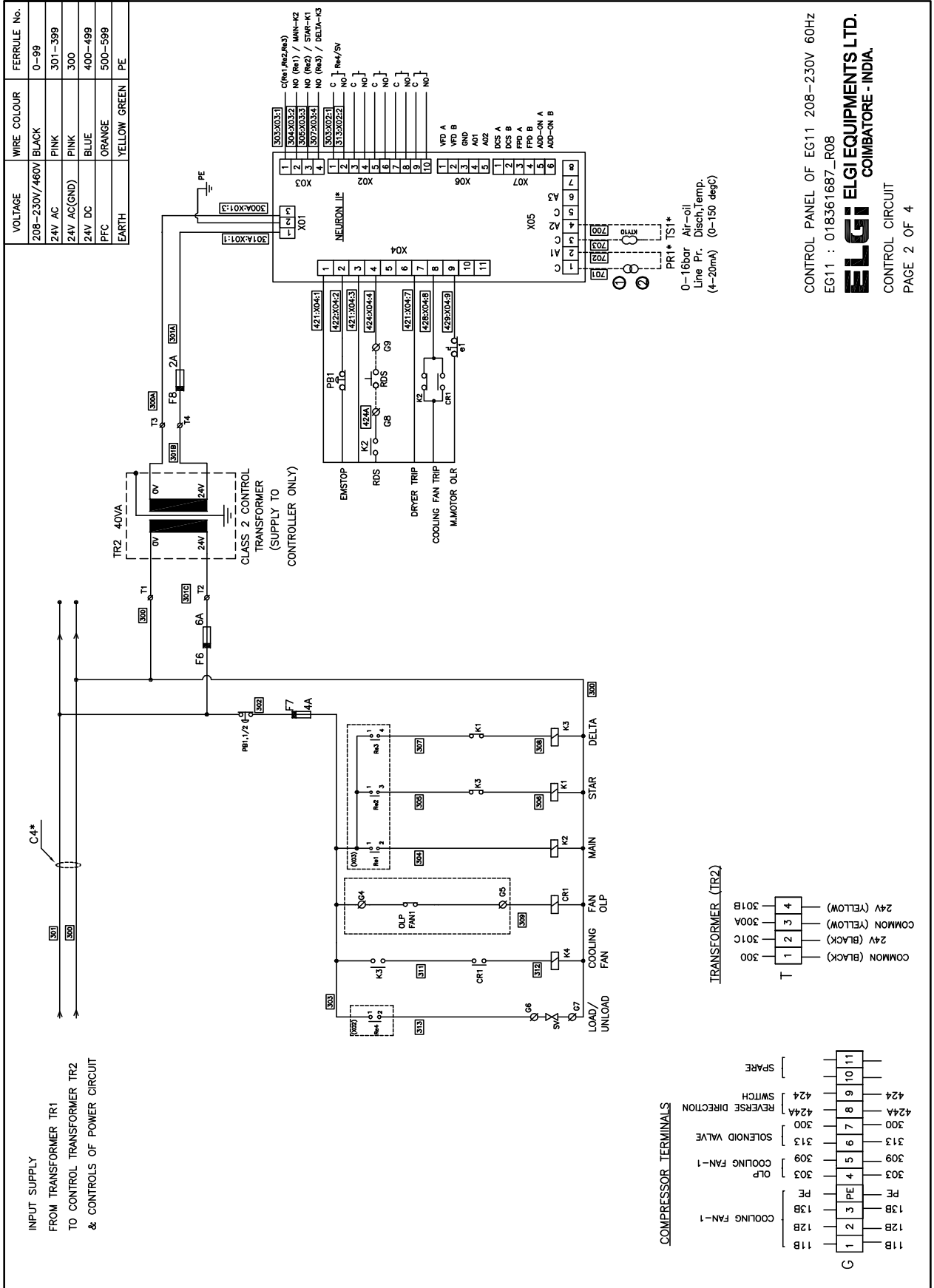

BILL OF MATERIAL

CODE	DESCRIPTION	MAKE	RATING	ELGI PART NO	QTY
K2-K3	POWER CONTACTOR (MAIN-DELTA)	SIEMENS	32A,3RT20 27-1AC20	008300020	2
K1	POWER CONTACTOR (STAR)	SIEMENS	25A,3RT20 26-1AC20	008300010	1
e1	OVERLOAD RELAY MAIN MOTOR	SIEMENS	10-40A, 3RB30 26-1VB0	018362658	1
K4	POWER CONTACTOR FOR COOLING FAN	SIEMENS	9A,3RT20 23-1AC20	0089000170	1
TR1	MULTI TAP TRANSFORMER	PLITRON	150VA, 0-0-230V-230V/0-24V	00893703A	1
TR2	CONTROL TRANSFORMER 40VA	BASIC ELECTRICAL	40VA, 0-24V/0-24V	00893703C	1
CR1	CONTROL RELAY	PHOENIX	2961192	008946236	1
E-STOP	EMERGENCY STOP PUSH BUTTON	TEKNIC	P2AML4	008940030	1
INCOMING TB	TERMINAL BLOCK - PHASE	PHOENIX	UHV 25 WITH HOOD	00894642H	3
END CLAMP	TERMINAL BLOCK - END CLAMP	PHOENIX	-	00894642G	4
PE	EARTH STRIP FOR COMPONENT EARTH WITH 5mm SREW WITH FLAT & SPRING WASHER	-	COPPER WITH TIN COATING	-	1
G,T	CONTROL TERMINALS	WAGO	281-101	018362734	15
PE	CONTROL TERMINALS (YELLOW GREEN)	WAGO	281-107	018362733	1
F	FUSE TERMINALS	WAGO	281-611	018362735	10
-	GLASS FUSE 20 x 5	PROTECTOR	SLOW BLOW 2A	00894642A	-
-	GLASS FUSE 20 x 5	PROTECTOR	SLOW BLOW 4A	00894644A	-
-	GLASS FUSE 20 x 5	PROTECTOR	SLOW BLOW 6A	00894646A	-
N II	NEURON CONTROLLER	ELGI	-	00897701N	1
M	MOTOR CONNECTION TERMINALS	CONNECTWELL	CTS16U	008946320	9
CONNECTERS	PLC CONNECTER SET	PHOENIX	(3,4,5,6,8,10,11 PINS)	00897903R	1 SET
-	END STOPPER	WAGO	249-117	018362736	6
RDS	REVERSE DIRECTION SWITCH	WABCO	M250450	008941151	1
PT	PRESSURE TRANSMITTER	DANFOSS	-	00897902N	1
TT	TEMPERATURE TRANSMITTER	DANFOSS	-	00897902M	1

CABLE	SIZE (AWG)
460V C	11KW
C1*	10
C2*	12
C3*	16
C4*	18

CONTROL PANEL OF EG11 208-230V 60Hz
EG11 : 018361687_R08

ELGI ELGI EQUIPMENTS LTD.
COIMBATORE - INDIA.

BILL OF MATERIALS
PAGE 3 OF 4

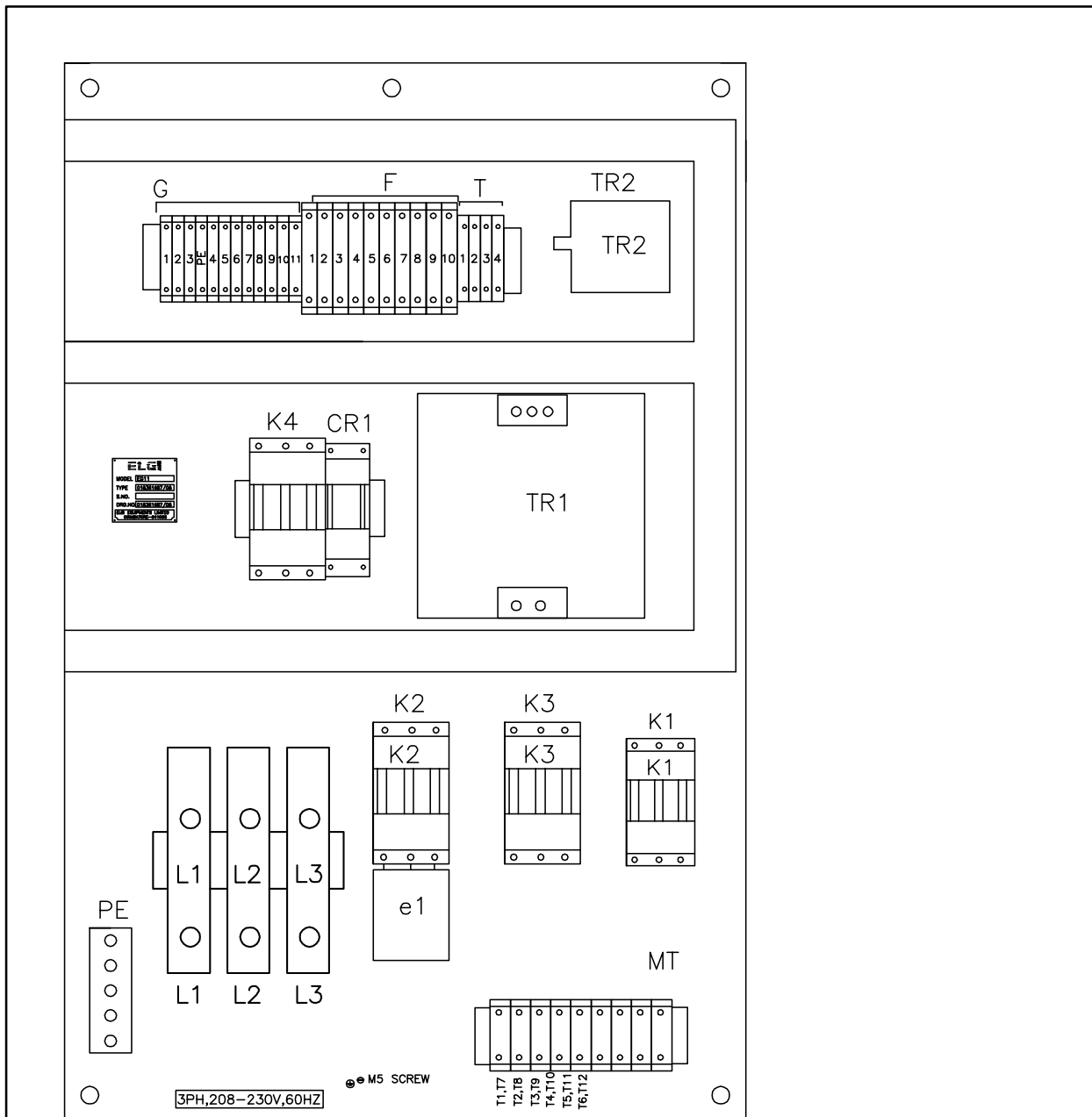

NOTE:

FOR BASE PLATE REFER LATEST REVISION DRAWING No. – 018361216

CONTROL PANEL OF EG11 208-230V 60Hz
EG11 : 018361687_R08

ELGI ELGI EQUIPMENTS LTD.,
COMBATORE - INDIA.

PANEL LAYOUT
PAGE 4 OF 4

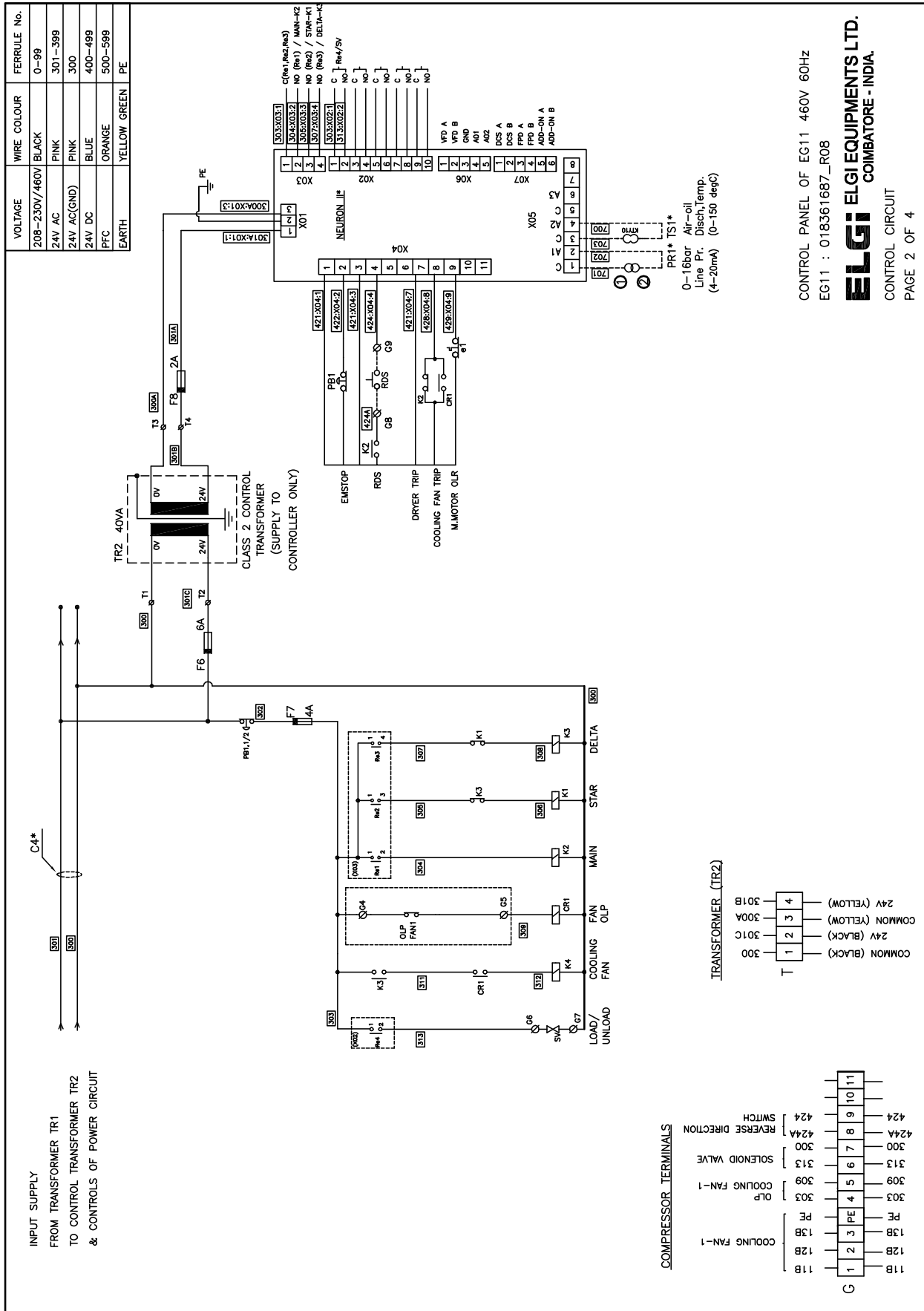

BILL OF MATERIAL

CODE	DESCRIPTION	MAKE	RATING	ELGI PART NO	QTY
K2-K3	POWER CONTACTOR (MAIN-DELTA)	SIEMENS	32A,3RT20 27-1AC20	008300020	2
K1	POWER CONTACTOR (STAR)	SIEMENS	25A,3RT20 26-1AC20	008300010	1
e1	OVERLOAD RELAY MAIN MOTOR	SIEMENS	10-40A, 3RB30 26-1VB0	018362658	1
K4	POWER CONTACTOR FOR COOLING FAN	SIEMENS	9A,3RT20 23-1AC20	0089000170	1
TR1	MULTI TAP TRANSFORMER	PLITRON	150VA, 0-0-230V-230V/0-24V	00893703A	1
TR2	CONTROL TRANSFORMER 40VA	BASIC ELECTRICAL	40VA, 0-24V/0-24V	00893703C	1
CR1	CONTROL RELAY	PHOENIX	2961192	008946236	1
E-STOP	EMERGENCY STOP PUSH BUTTON	TEKNIC	P2AML4	008940030	1
INCOMING TB	TERMINAL BLOCK - PHASE	PHOENIX	UHV 25 WITH HOOD	00894642H	3
END CLAMP	TERMINAL BLOCK - END CLAMP	PHOENIX	-	00894642G	4
PE	EARTH STRIP FOR COMPONENT EARTH WITH 5mm SREW WITH FLAT & SPRING WASHER	-	COPPER WITH TIN COATING	-	1
G,T	CONTROL TERMINALS	WAGO	281-101	018362734	15
PE	CONTROL TERMINALS (YELLOW GREEN)	WAGO	281-107	018362733	1
F	FUSE TERMINALS	WAGO	281-611	018362735	10
-	GLASS FUSE 20 x 5	PROTECTRON	SLOW BLOW 2A	00894642A	-
-	GLASS FUSE 20 x 5	PROTECTRON	SLOW BLOW 4A	00894644A	-
-	GLASS FUSE 20 x 5	PROTECTRON	SLOW BLOW 6A	00894646A	-
N II	NEURON CONTROLLER	ELGI	-	00897701N	1
M	MOTOR CONNECTION TERMINALS	CONNECTWELL	CTS16U	008946320	9
CONNECTERS	PLC CONNECTER SET	PHOENIX	(3,4,5,6,8,10,11 PINS)	00897903R	1 SET
-	END STOPPER	WAGO	249-117	018362736	6
RDS	REVERSE DIRECTION SWITCH	WABCO	M250450	008941151	1
PT	PRESSURE TRANSMITTER	DANFOSS	-	00897902N	1
TT	TEMPERATURE TRANSMITTER	DANFOSS	-	00897902M	1

CABLE	SIZE (AWG)
460V C	11KW
C1*	10
C2*	12
C3*	16
C4*	18

CONTROL PANEL OF EG11 460V 60Hz
EG11 : 018361687_R08

ELGI ELGI EQUIPMENTS LTD.
COIMBATORE - INDIA.

BILL OF MATERIALS
PAGE 3 OF 4

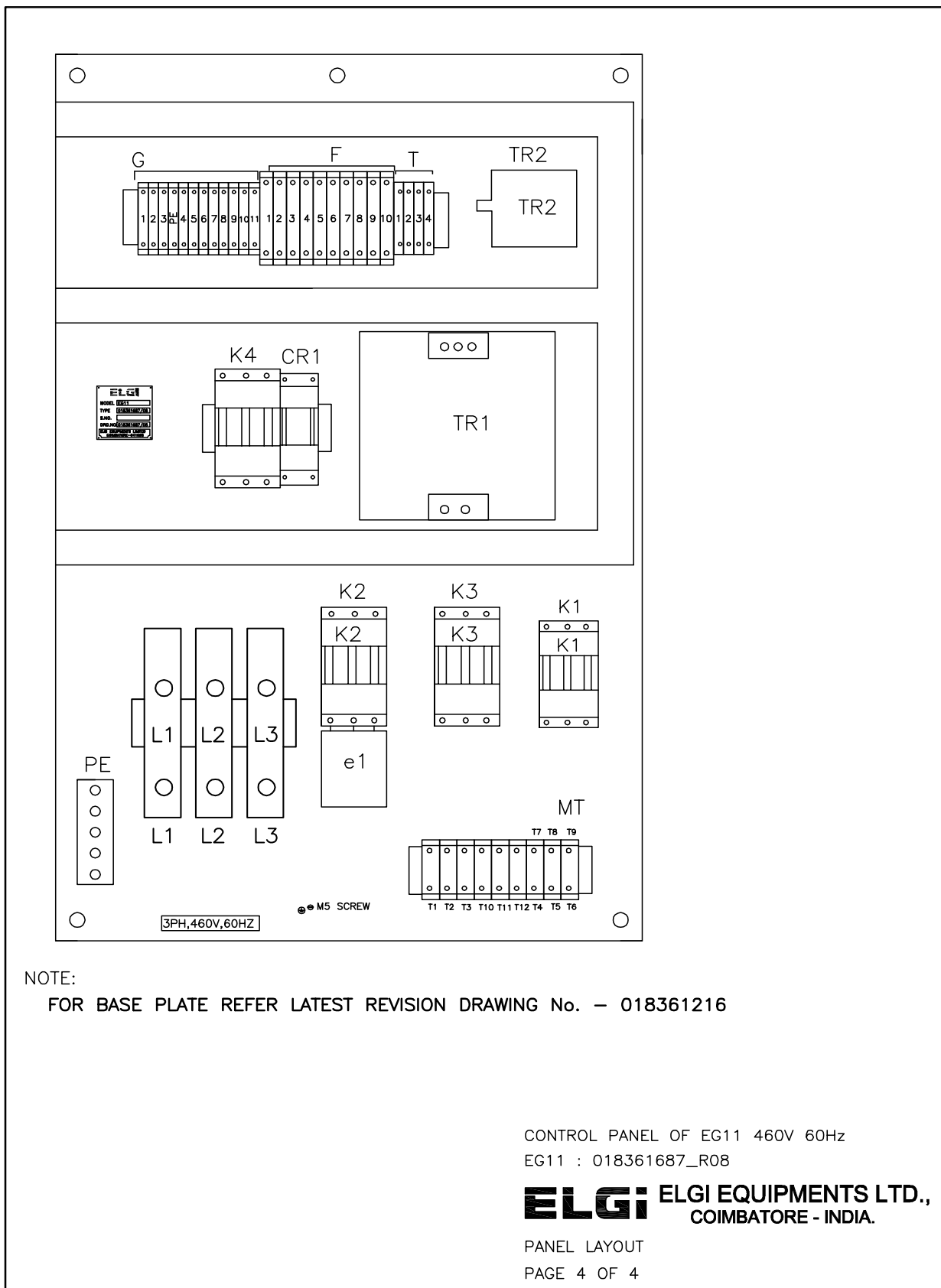

VOLTAGE	WIRE COLOUR	FERRULE No.
208-230V/460V	BLACK	0-99
24V AC	PINK	301-399
24V AC(GND)	PINK	300
24V DC	BLUE	400-499
PFC	ORANGE	500-599
EARTH	YELLOW GREEN	PE

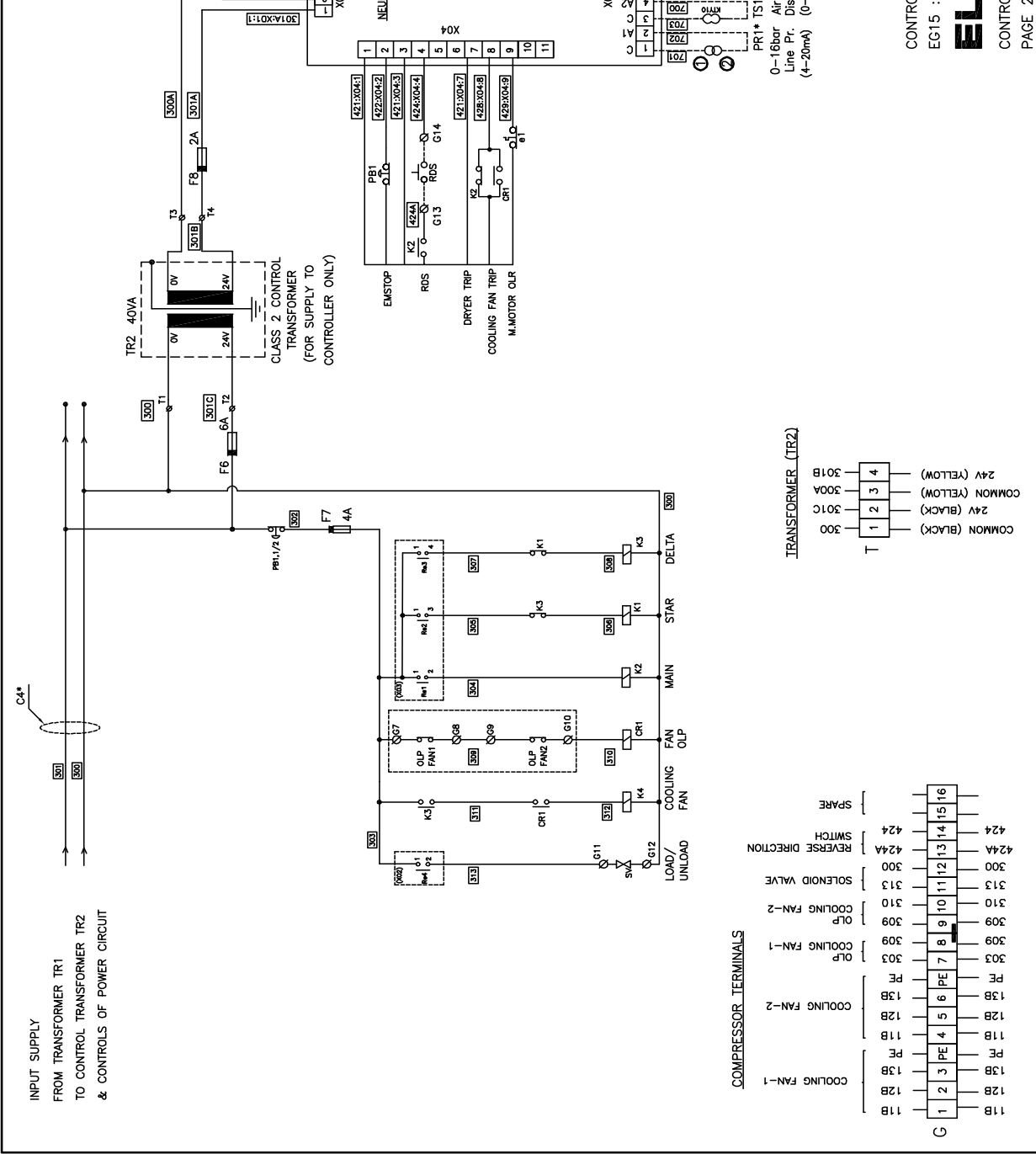

INPUT SUPPLY
FROM TRANSFORMER TR1
TO CONTROL TRANSFORMER TR2
& CONTROLS OF POWER CIRCUIT

CLASS 2 CONTROL
TRANSFORMER (TR2)
(FOR SUPPLY TO
CONTROLLER ONLY)

TRANSFORMER (TR2)

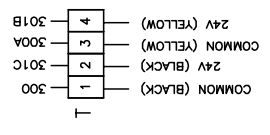

COMPRESSOR TERMINALS

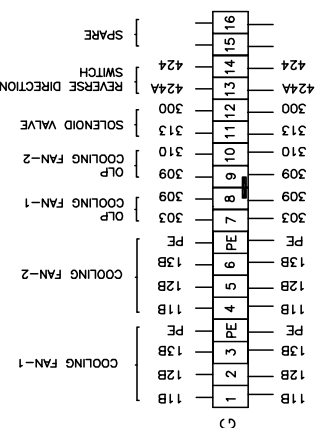

CONTROL PANEL EG15 208-230V 60HZ
EG15 : 018361688_R08

ELGI ELGI EQUIPMENTS LTD.
COIMBATORE - INDIA.

CONTROL CIRCUIT
PAGE 2 OF 4

BILL OF MATERIAL

CODE	DESCRIPTION	MAKE	RATING	ELGI PART NO	QTY
K2-K3	POWER CONTACTOR (MAIN-DELTA)	SIEMENS	50A,3RT10 36-1AC20	008930106	2
K1	POWER CONTACTOR (STAR)	SIEMENS	32A,3RT20 27-1AC20	008300020	1
e1	OVERLOAD RELAY MAIN MOTOR	SIEMENS	13-50A, 3RB20 36-1UB0	018362637	1
K4	POWER CONTACTOR FOR COOLING FAN	SIEMENS	9A,3RT20 23-1AC20	008900170	1
TR1	MULTI TAP TRANSFORMER	PLITRON	150VA, 0-0-230V-230V/0-24V	00893703A	1
TR2	CONTROL TRANSFORMER 40VA	BASIC ELECTRICAL	40VA, 0-24V/0-24V	00893703C	1
CR1	CONTROL RELAY	PHOENIX	2961192	008946236	1
E-STOP	EMERGENCY STOP PUSH BUTTON	TEKNIC	P2AML4	008940030	1
INCOMING TB	TERMINAL BLOCK - PHASE	PHOENIX	UHV 25 WITH HOOD	00894642H	3
END CLAMP	TERMINAL BLOCK - END CLAMP	PHOENIX	-	00894642G	4
PE	EARTH STRIP FOR COMPONENT EARTH WITH 5mm SREW WITH FLAT & SPRING WASHER	-	COPPER WITH TIN COATING	-	1
G,T	CONTROL TERMINALS	WAGO	281-101	018362734	20
PE	CONTROL TERMINALS (YELLOW GREEN)	WAGO	281-107	018362733	2
F	FUSE TERMINALS	WAGO	281-611	018362735	10
-	GLASS FUSE 20 x 5	PROTECTRON	SLOW BLOW 2A	00894642A	-
-	GLASS FUSE 20 x 5	PROTECTRON	SLOW BLOW 4A	00894644A	-
-	GLASS FUSE 20 x 5	PROTECTRON	SLOW BLOW 6A	00894646A	-
N II	NEURON CONTROLLER	ELGI	-	00897701N	1
M	MOTOR CONNECTION TERMINALS	CONNECTWELL	CTS16U	008946320	9
CONNECTERS	PLC CONNECTER SET	PHOENIX	(3,4,5,6,8,10,11 PINS)	00897903R	1 SET
-	END STOPPER	WAGO	249-117	018362736	6
RDS	REVERSE DIRECTION SWITCH	WABCO	M250450	008941151	1
-	NO CONTACT FOR CONTACTOR	SIEMENS	3RH19 21-1CA10	008900380	2
-	NC CONTACT FOR CONTACTOR	SIEMENS	3RH19 21-1CA01	008900390	2
PT	PRESSURE TRANSMITTER	DANFOSS	-	00897902N	1
TT	TEMPERATURE TRANSMITTER	DANFOSS	-	00897902M	1

CABLE	SIZE (AWG)
460V C	11KW
C1*	8
C2*	10
C3*	16
C4*	18

CONTROL PANEL EG15 208-230V 60Hz
EG15 : 018361688_R08

ELGI ELGI EQUIPMENTS LTD.
COMBATORE - INDIA.

BILL OF MATERIALS
PAGE 3 OF 4

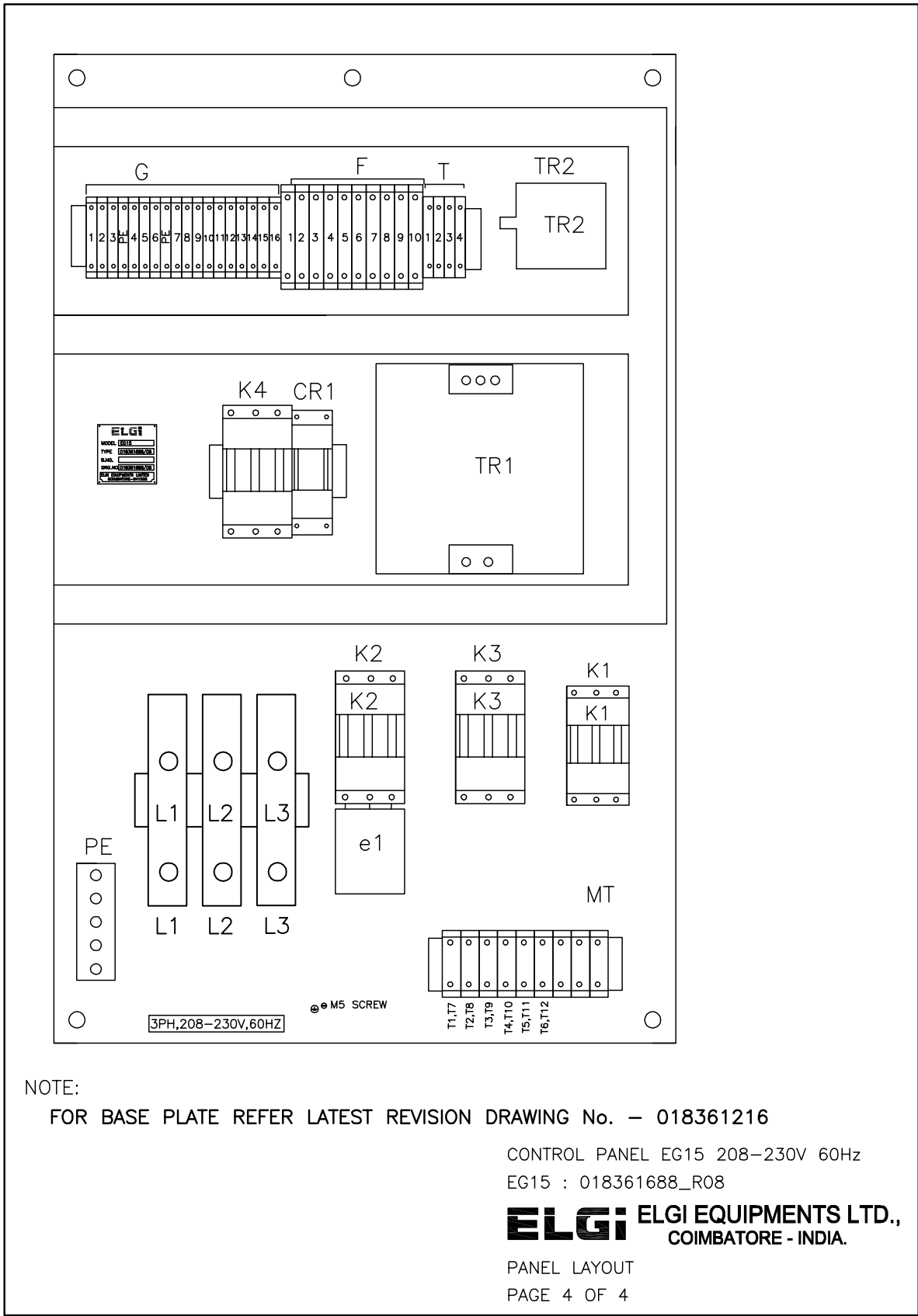

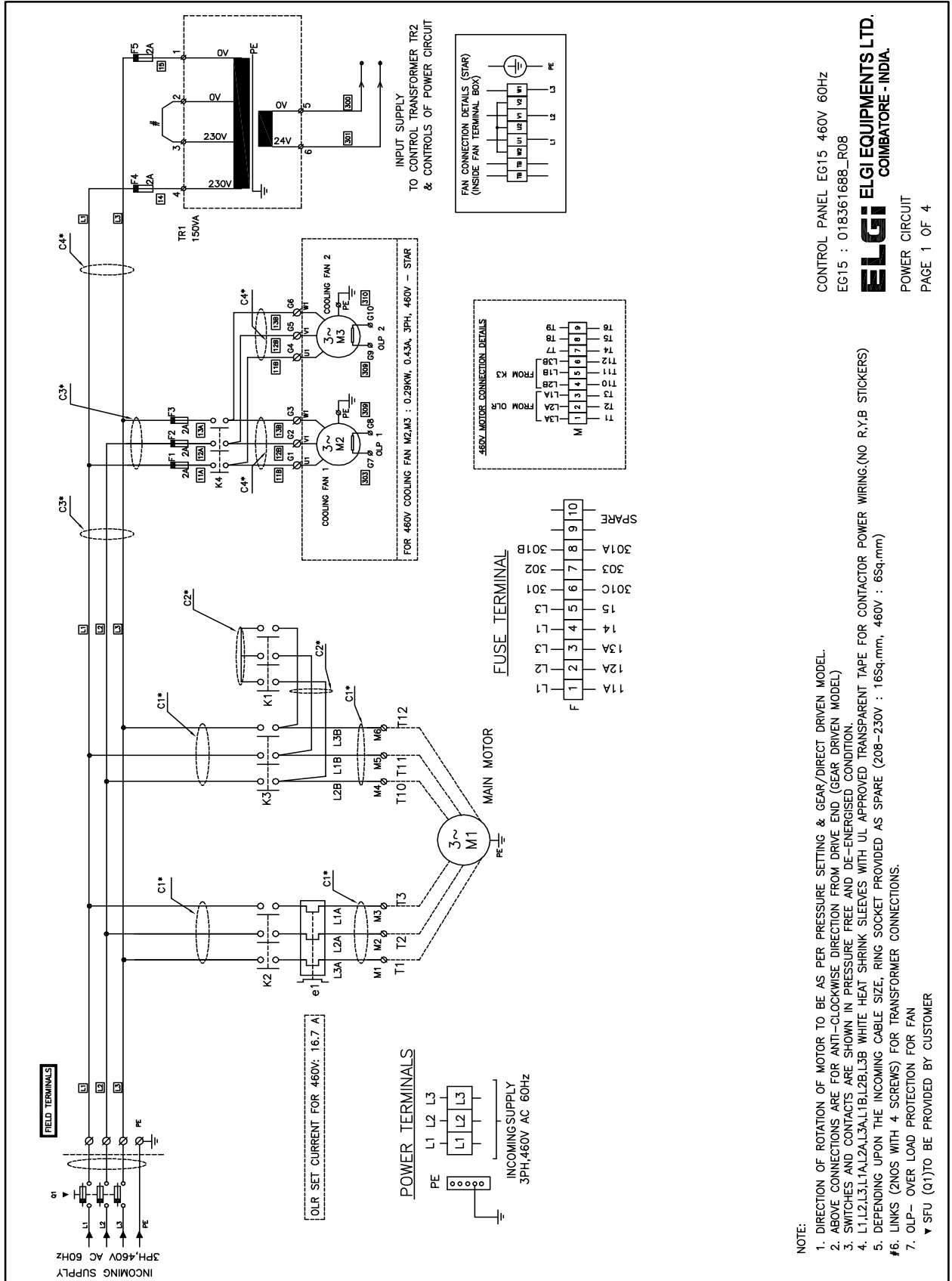

BILL OF MATERIAL

CODE	DESCRIPTION	MAKE	RATING	ELGI PART NO	QTY
K2-K3	POWER CONTACTOR (MAIN-DELTA)	SIEMENS	50A,3RT10 36-1AC20	008930106	2
K1	POWER CONTACTOR (STAR)	SIEMENS	32A,3RT20 27-1AC20	008300020	1
e1	OVERLOAD RELAY MAIN MOTOR	SIEMENS	13-50A, 3RB20 36-1UB0	018362637	1
K4	POWER CONTACTOR FOR COOLING FAN	SIEMENS	9A,3RT20 23-1AC20	008900170	1
TR1	MULTI TAP TRANSFORMER	PLITRON	150VA, 0-0-230V-230V/0-24V	00893703A	1
TR2	CONTROL TRANSFORMER 40VA	BASIC ELECTRICAL	40VA, 0-24V/0-24V	00893703C	1
CR1	CONTROL RELAY	PHOENIX	2961192	008946236	1
E-STOP	EMERGENCY STOP PUSH BUTTON	TEKNIC	P2AML4	008940030	1
INCOMING TB	TERMINAL BLOCK - PHASE	PHOENIX	UHV 25 WITH HOOD	00894642H	3
END CLAMP	TERMINAL BLOCK - END CLAMP	PHOENIX	-	00894642G	4
PE	EARTH STRIP FOR COMPONENT EARTH WITH 5mm SREW WITH FLAT & SPRING WASHER	-	COPPER WITH TIN COATING	-	1
G,T	CONTROL TERMINALS	WAGO	281-101	018362734	20
PE	CONTROL TERMINALS (YELLOW GREEN)	WAGO	281-107	018362733	2
F	FUSE TERMINALS	WAGO	281-611	018362735	10
-	GLASS FUSE 20 x 5	PROTECTRON	SLOW BLOW 2A	00894642A	-
-	GLASS FUSE 20 x 5	PROTECTRON	SLOW BLOW 4A	00894644A	-
-	GLASS FUSE 20 x 5	PROTECTRON	SLOW BLOW 6A	00894646A	-
N II	NEURON CONTROLLER	ELGI	-	00897701N	1
M	MOTOR CONNECTION TERMINALS	CONNECTWELL	CTS16U	008946320	9
CONNECTERS	PLC CONNECTER SET	PHOENIX	(3,4,5,6,8,10,11 PINS)	00897903R	1 SET
-	END STOPPER	WAGO	249-117	018362736	6
RDS	REVERSE DIRECTION SWITCH	WABCO	M250450	008941151	1
-	NO CONTACT FOR CONTACTOR	SIEMENS	3RH19 21-1CA10	008900380	2
-	NC CONTACT FOR CONTACTOR	SIEMENS	3RH19 21-1CA01	008900390	2
PT	PRESSURE TRANSMITTER	DANFOSS	-	00897902N	1
TT	TEMPERATURE TRANSMITTER	DANFOSS	-	00897902M	1

CABLE	SIZE (AWG)
460V C	11KW
C1*	8
C2*	10
C3*	16
C4*	18

CONTROL PANEL EG15 460V 60HZ
EG15 : 018361688_R08

ELGI ELGI EQUIPMENTS LTD.
COIMBATORE - INDIA.

BILL OF MATERIALS
PAGE 3 OF 4

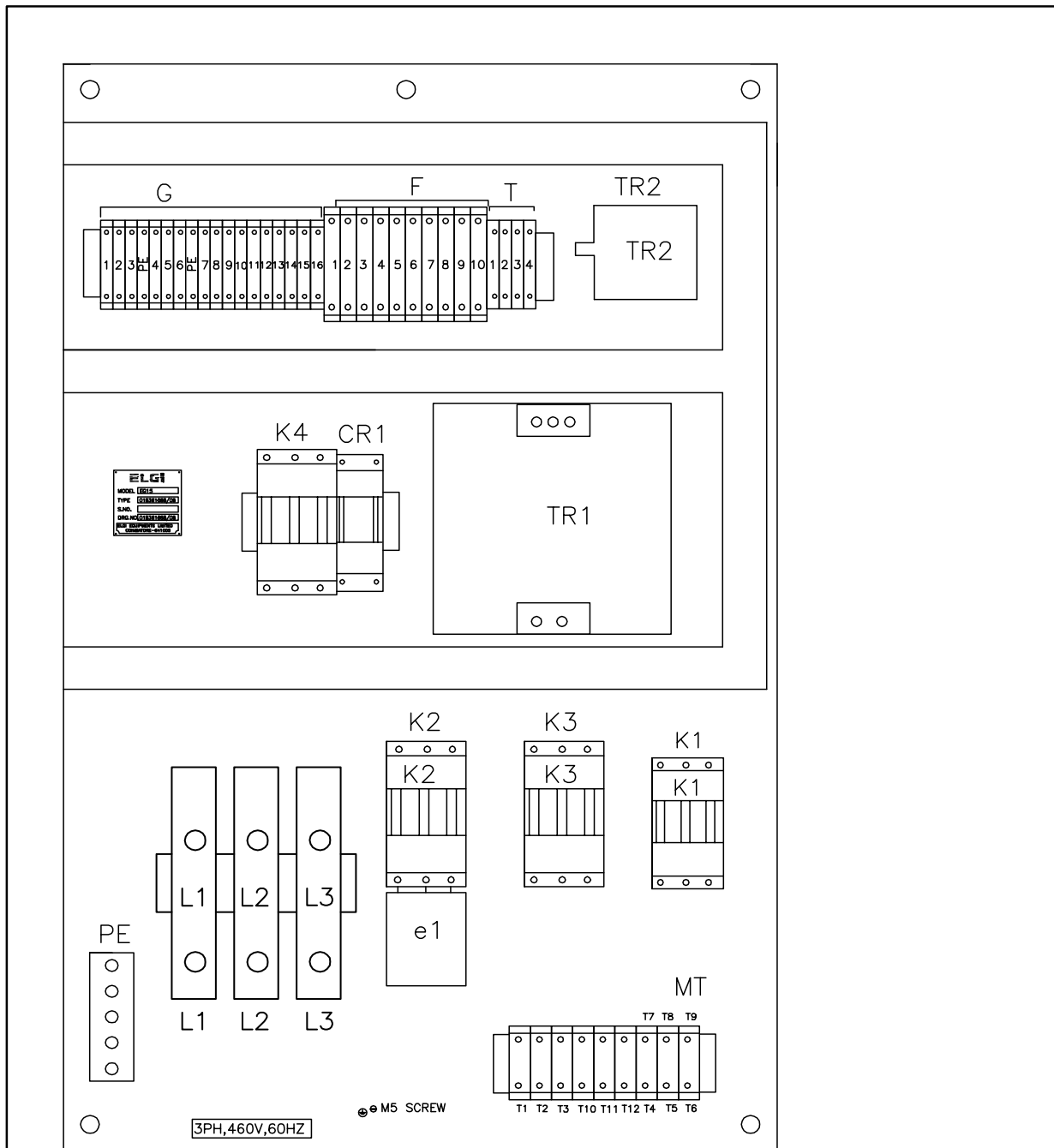

NOTE:

FOR BASE PLATE REFER LATEST REVISION DRAWING No. – 018361216

CONTROL PANEL EG15 460V 60Hz

EG15 : 018361688_R08

ELGI ELGI EQUIPMENTS LTD.,
COIMBATORE - INDIA.

PANEL LAYOUT

PAGE 4 OF 4

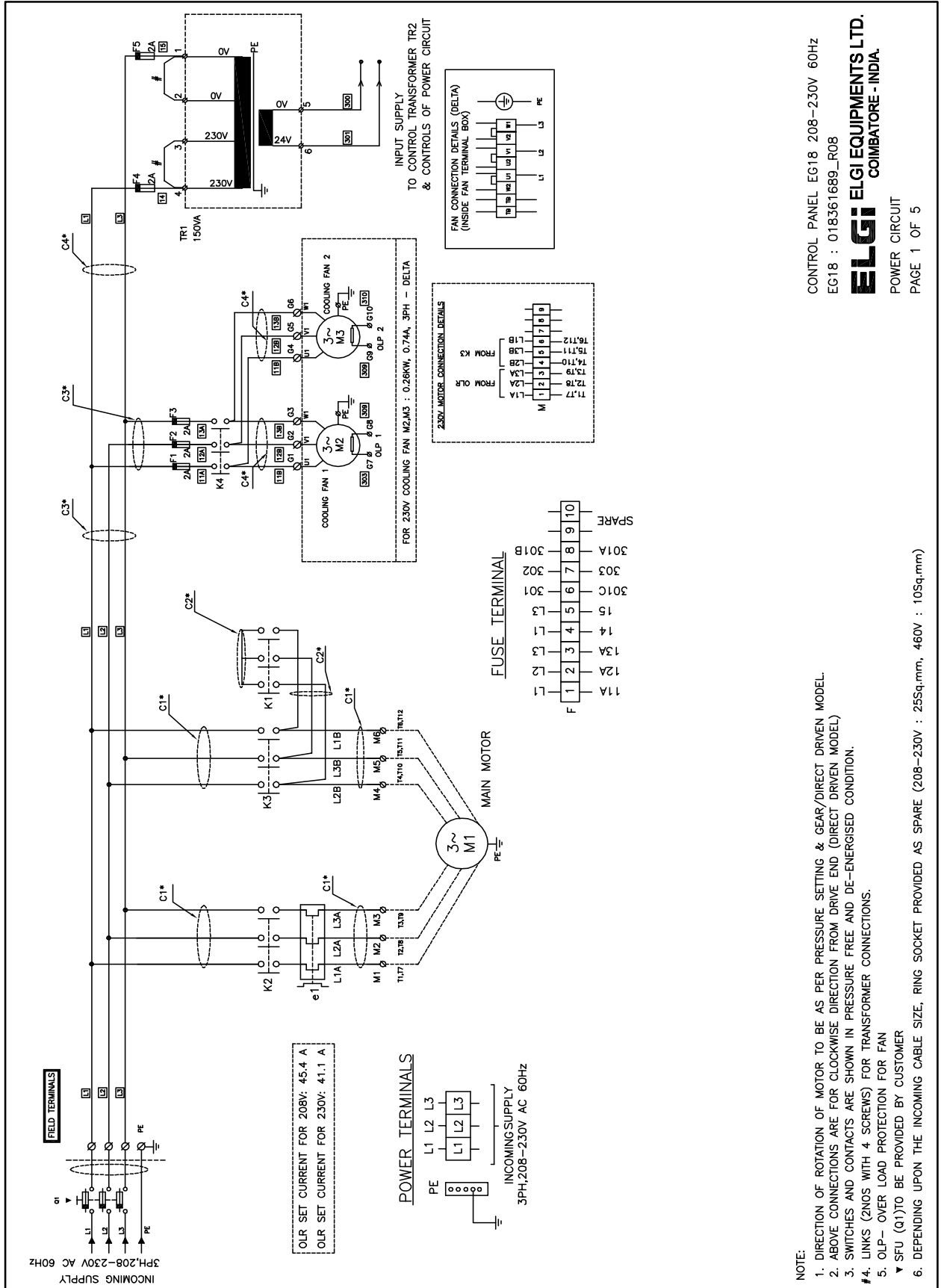

CONTROL PANEL EG18 208-230V 60HZ
EG18 : 018361689_R08
ELGI ELGI EQUIPMENTS LTD.
COIMBATORE - INDIA.
POWER CIRCUIT
PAGE 1 OF 5

BILL OF MATERIAL

CODE	DESCRIPTION	MAKE	RATING	ELGI PART NO	QTY
K2-K3	POWER CONTACTOR (MAIN-DELTA)	SIEMENS	50A,3RT10 36-1AC20	008930106	2
K1	POWER CONTACTOR (STAR)	SIEMENS	40A,3RT20 28-1AC20-OJAO	008900190	1
e1	OVERLOAD RELAY MAIN MOTOR	SIEMENS	13-50A, 3RB20 36-1UB0	018362637	1
K4	POWER CONTACTOR FOR COOLING FAN	SIEMENS	9A,3RT20 23-1AC20	008900170	1
TR1	MULTI TAP TRANSFORMER	PLITRON	150VA, 0-0-230V-230V/0-24V	00893703A	1
TR2	CONTROL TRANSFORMER 40VA	BASIC ELECTRICAL	40VA, 0-24V/0-24V	00893703C	1
CR1	CONTROL RELAY	PHOENIX	2961192	008946236	1
E-STOP	EMERGENCY STOP PUSH BUTTON	TEKNIC	P2AML4	008940030	1
INCOMING TB	TERMINAL BLOCK - PHASE	PHOENIX	UHV 50 WITH HOOD	00894642J	3
END CLAMP	TERMINAL BLOCK - END CLAMP	PHOENIX	-	00894642G	4
PE	EARTH STRIP FOR COMPONENT EARTH WITH 5mm SREW WITH FLAT & SPRING WASHER	-	COPPER WITH TIN COATING	-	1
G,T	CONTROL TERMINALS	WAGO	281-101	018362734	20
PE	CONTROL TERMINALS (YELLOW GREEN)	WAGO	281-107	018362733	2
F	FUSE TERMINALS	WAGO	281-611	018362735	10
-	GLASS FUSE 20 x 5	PROTECTRON	SLOW BLOW 2A	00894642A	-
-	GLASS FUSE 20 x 5	PROTECTRON	SLOW BLOW 4A	00894644A	-
-	GLASS FUSE 20 x 5	PROTECTRON	SLOW BLOW 6A	00894646A	-
N II*	NEURON CONTROLLER	ELGI	-	00897701N	1
M	MOTOR CONNECTION TERMINALS	CONNECTWELL	CTS16U	008946320	9
CONNECTERS	PLC CONNECTER SET	PHOENIX	(3,4,5,6,8,10,11 PINS)	00897903R	1 SET
-	END STOPPER	WAGO	249-117	018362736	6
RDS	REVERSE DIRECTION SWITCH	WARCO	M250450	008941151	1
-	NO CONTACT FOR CONTACTOR	SIEMENS	3RH19 21-1CA10	008900380	2
-	NC CONTACT FOR CONTACTOR	SIEMENS	3RH19 21-1CA01	008900390	2
PT	PRESSURE TRANSMITTER	DANFOSS	-	00897902N	1
TT	TEMPERATURE TRANSMITTER	DANFOSS	-	00897902M	1

CABLE	SIZE (AWG)
208-230V	18KW
C1*	6
C2*	8
C3*	16
C4*	18

CONTROL PANEL EG18 208-230V 60HZ
EG18 : 018361689_R08

ELGI ELGI EQUIPMENTS LTD.
COIMBATORE - INDIA.

BILL OF MATERIALS

PAGE 4 OF 5



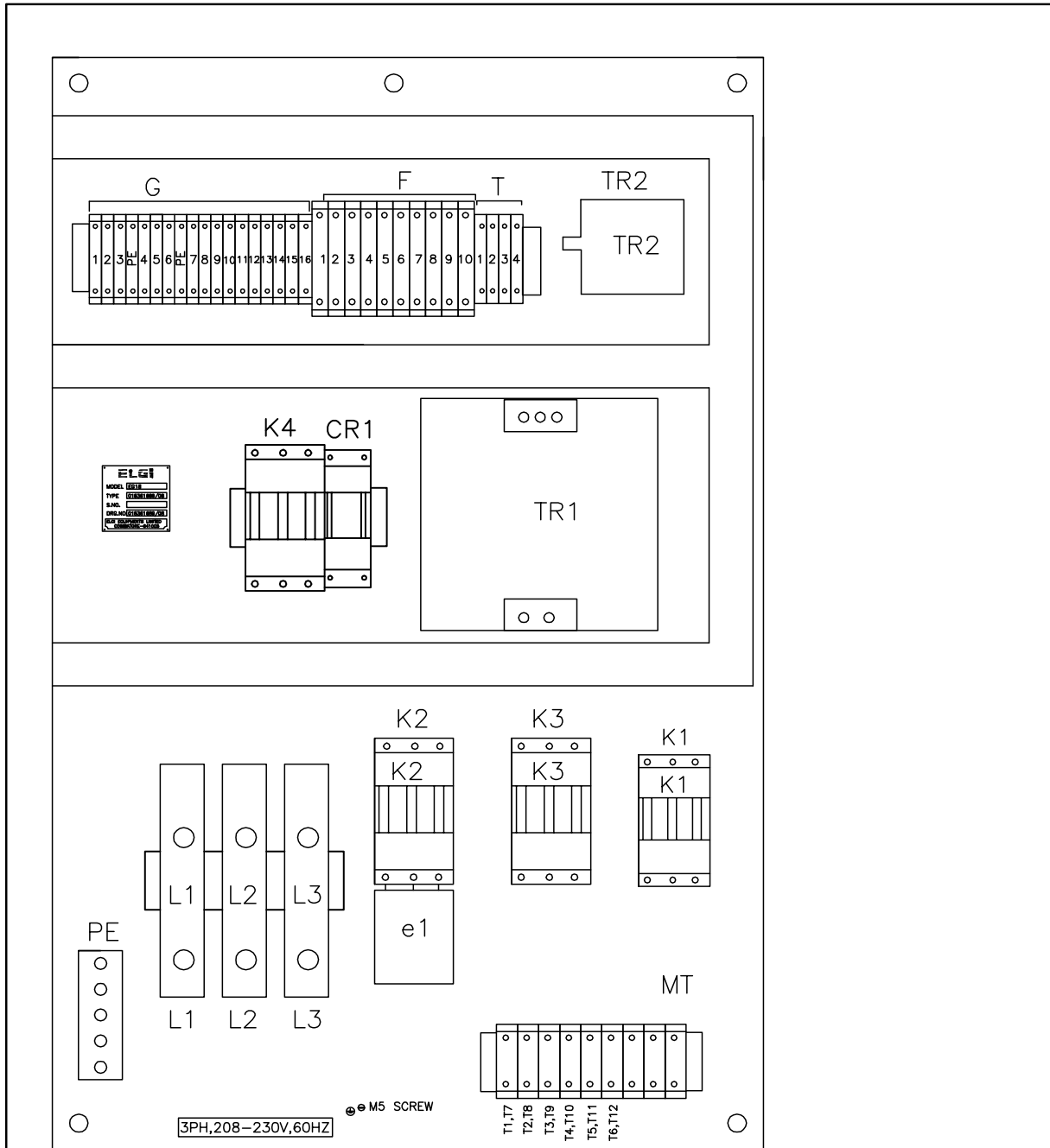

NOTE:

FOR BASE PLATE REFER LATEST REVISION DRAWING No. – 018361216

CONTROL PANEL EG18 208–230V 60Hz

EG18 : 018361689_R08

ELGI ELGI EQUIPMENTS LTD.,
COIMBATORE - INDIA.

PANEL LAYOUT

PAGE 5 OF 5

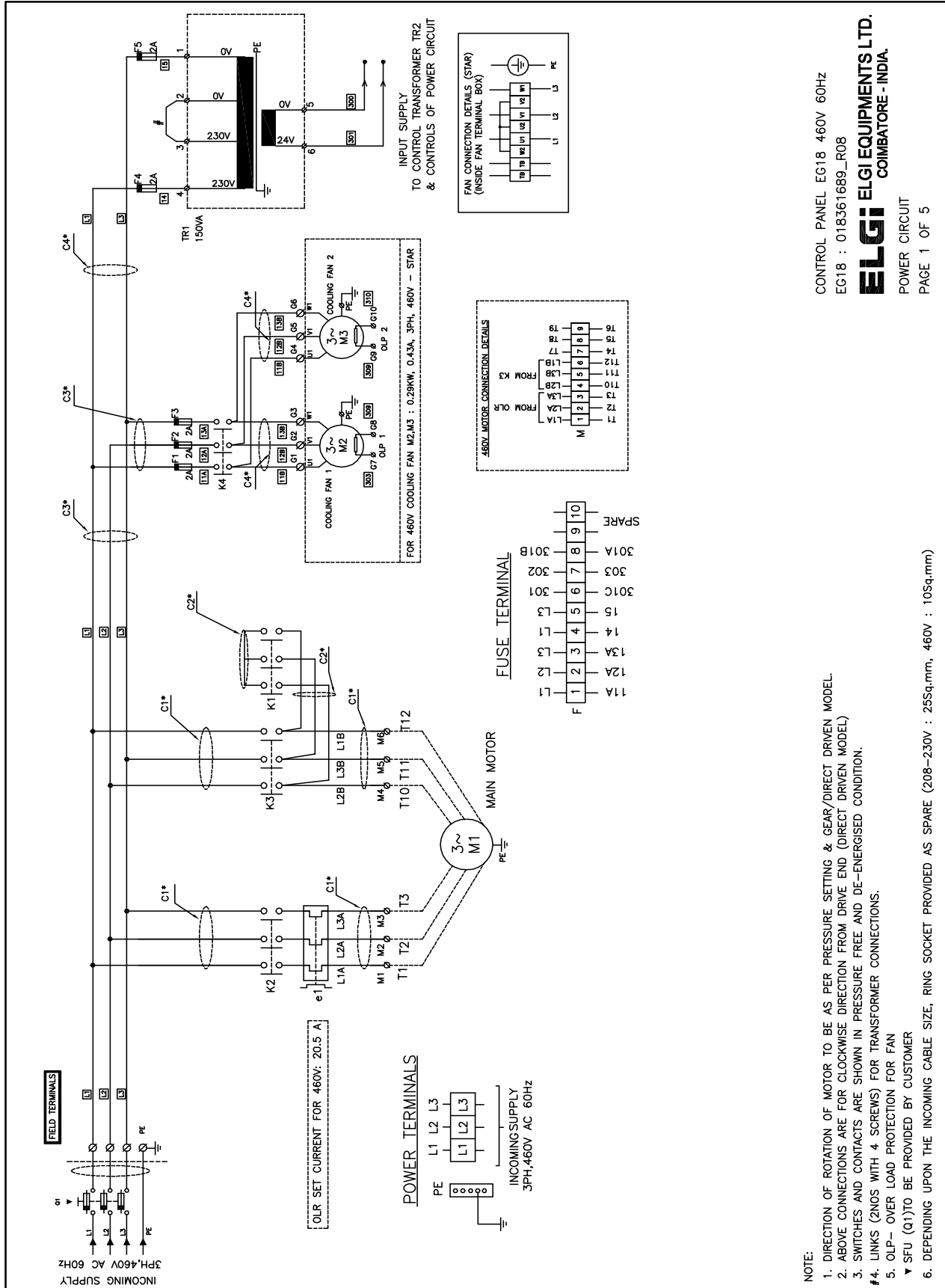

CONTROL PANEL EG18 460V 60HZ
EG18 : 018361689_R08

ELGI ELGIEQUIPMENTS LTD.
COIMBATORE - INDIA.

POWER CIRCUIT
PAGE 1 OF 5

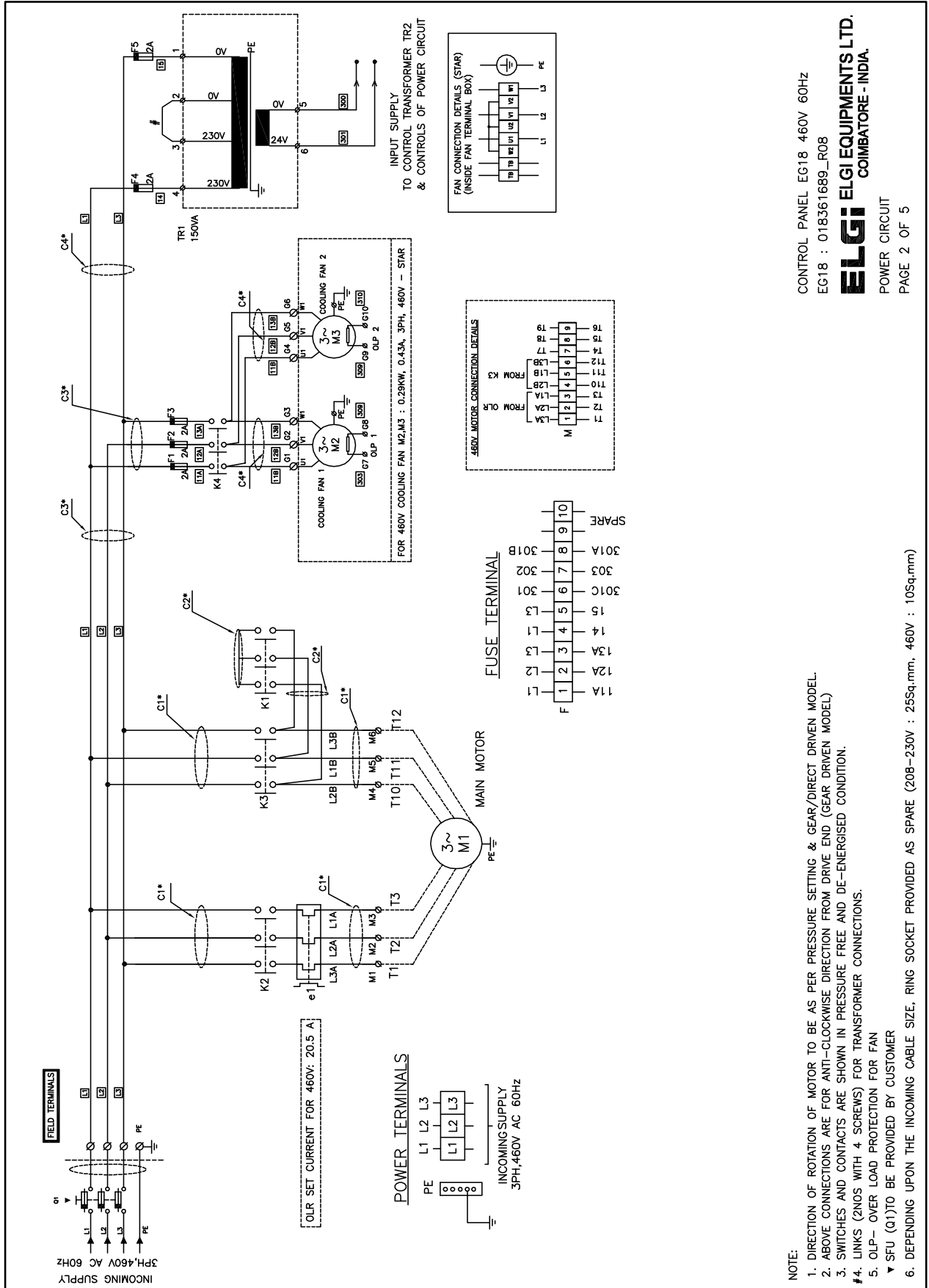

CONTROL PANEL EG18 460V 60HZ
EG18 : 018361689_R08
ELGI EQUIPMENTS LTD.
COIMBATORE - INDIA.
POWER CIRCUIT
PAGE 2 OF 5

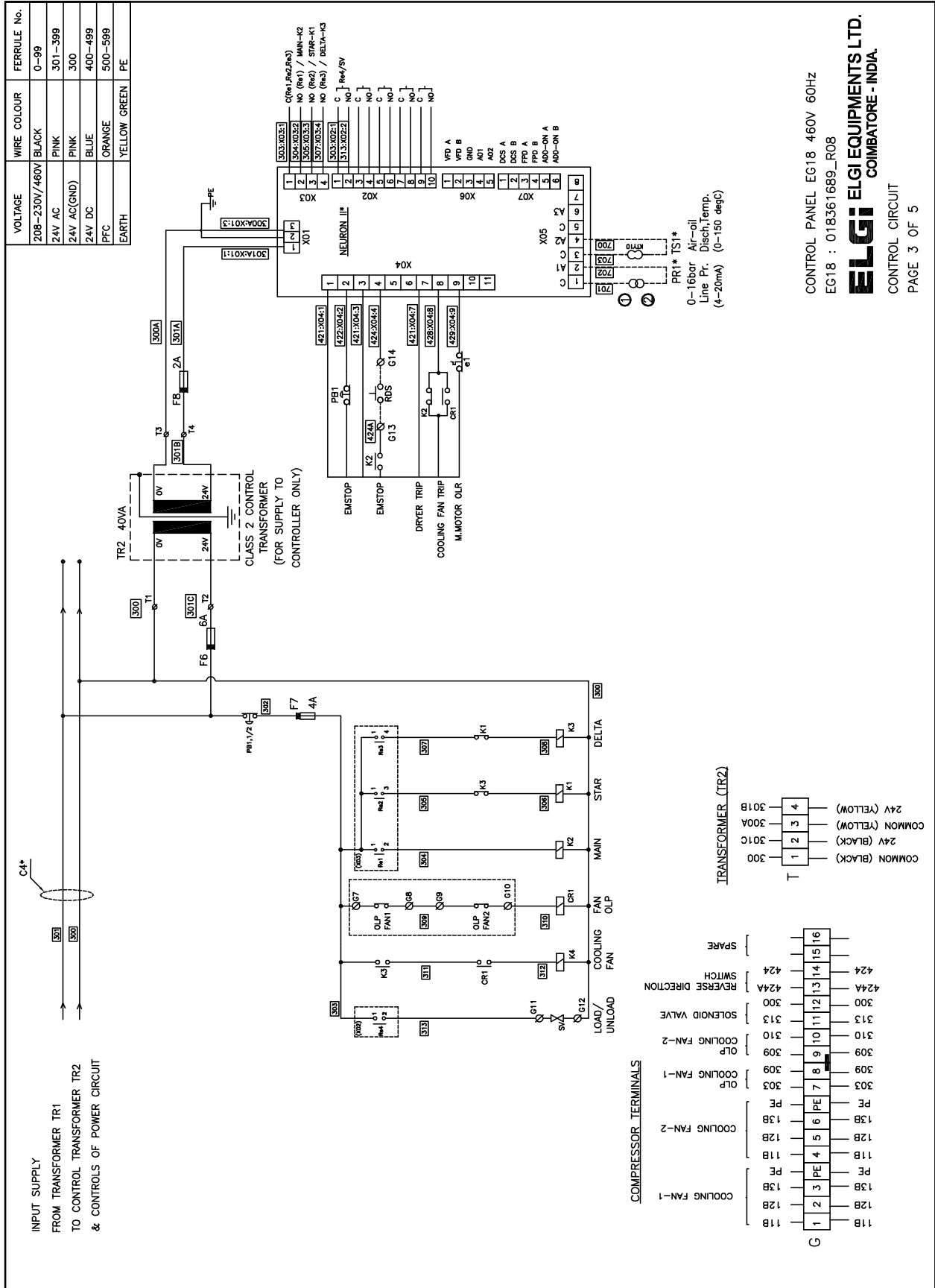

CONTROL PANEL EG18 460V 60Hz
 EG18 : 018361689_R08
ELGI ELGI EQUIPMENTS LTD.
 COIMBATORE - INDIA.
 CONTROL CIRCUIT
 PAGE 3 OF 5

BILL OF MATERIAL

CODE	DESCRIPTION	MAKE	RATING	ELGI PART NO	QTY
K2-K3	POWER CONTACTOR (MAIN-DELTA)	SIEMENS	50A,3RT10 36-1AC20	008930106	2
K1	POWER CONTACTOR (STAR)	SIEMENS	40A,3RT20 28-1AC20-0JA0	008900190	1
e1	OVERLOAD RELAY MAIN MOTOR	SIEMENS	13-50A, 3RB20 36-1UB0	018362637	1
K4	POWER CONTACTOR FOR COOLING FAN	SIEMENS	9A,3RT20 23-1AC20	008900170	1
TR1	MULTI TAP TRANSFORMER	PLITRON	150VA, 0-0-230V-230V/0-24V	00893703A	1
TR2	CONTROL TRANSFORMER 40VA	BASIC ELECTRICAL	40VA, 0-24V/0-24V	00893703C	1
CR1	CONTROL RELAY	PHOENIX	2961192	008946236	1
E-STOP	EMERGENCY STOP PUSH BUTTON	TEKNIC	P2AML4	008940030	1
INCOMING TB	TERMINAL BLOCK - PHASE	PHOENIX	UHV 50 WITH HOOD	00894642J	3
END CLAMP	TERMINAL BLOCK - END CLAMP	PHOENIX	-	00894642G	4
PE	EARTH STRIP FOR COMPONENT EARTH WITH 5mm SREW WITH FLAT & SPRING WASHER	-	COPPER WITH TIN COATING	-	1
G,T	CONTROL TERMINALS	WAGO	281-101	018362734	20
PE	CONTROL TERMINALS (YELLOW GREEN)	WAGO	281-107	018362733	2
F	FUSE TERMINALS	WAGO	281-611	018362735	10
-	GLASS FUSE 20 x 5	PROTECTRON	SLOW BLOW 2A	00894642A	-
-	GLASS FUSE 20 x 5	PROTECTRON	SLOW BLOW 4A	00894644A	-
-	GLASS FUSE 20 x 5	PROTECTRON	SLOW BLOW 6A	00894646A	-
N II*	NEURON CONTROLLER	ELGI	-	00897701N	1
M	MOTOR CONNECTION TERMINALS	CONNECTWELL	CTS16J	008946320	9
CONNECTERS	PLC CONNECTER SET	PHOENIX	(3,4,5,6,8,10,11 PINS)	00897903R	1 SET
-	END STOPPER	WAGO	249-117	018362736	6
RDS	REVERSE DIRECTION SWITCH	WABCO	M250450	008941151	1
-	NO CONTACT FOR CONTACTOR	SIEMENS	3RH19 21-1CA10	008900380	2
-	NC CONTACT FOR CONTACTOR	SIEMENS	3RH19 21-1CA01	008900390	2
PT	PRESSURE TRANSMITTER	DANFOSS	-	00897902N	1
TT	TEMPERATURE TRANSMITTER	DANFOSS	-	00897902M	1

CABLE	SIZE (AWG)
208-230V	18KW
C1*	6
C2*	8
C3*	16
C4*	18

CONTROL PANEL EG18 460V 60Hz
EG18 : 018361689_R08

ELGI ELGI EQUIPMENTS LTD.
COIMBATORE - INDIA.

BILL OF MATERIALS
PAGE 4 OF 5

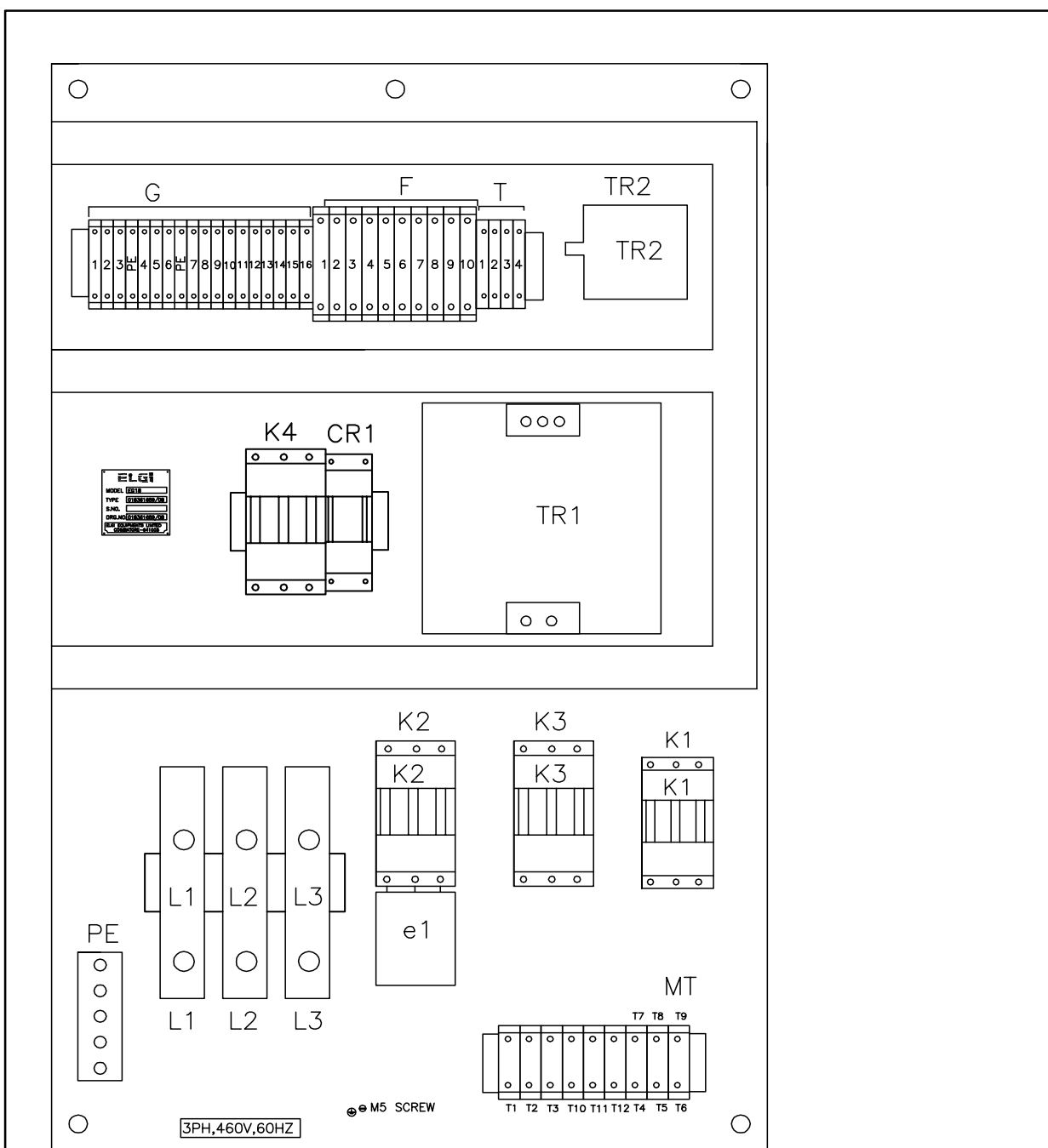

NOTE:
 FOR BASE PLATE REFER LATEST REVISION DRAWING No. – 018361216

CONTROL PANEL EG18 460V 60Hz
 EG18 : 018361689_R08

ELGI ELGI EQUIPMENTS LTD.,
 COIMBATORE - INDIA.

PANEL LAYOUT
 PAGE 5 OF 5

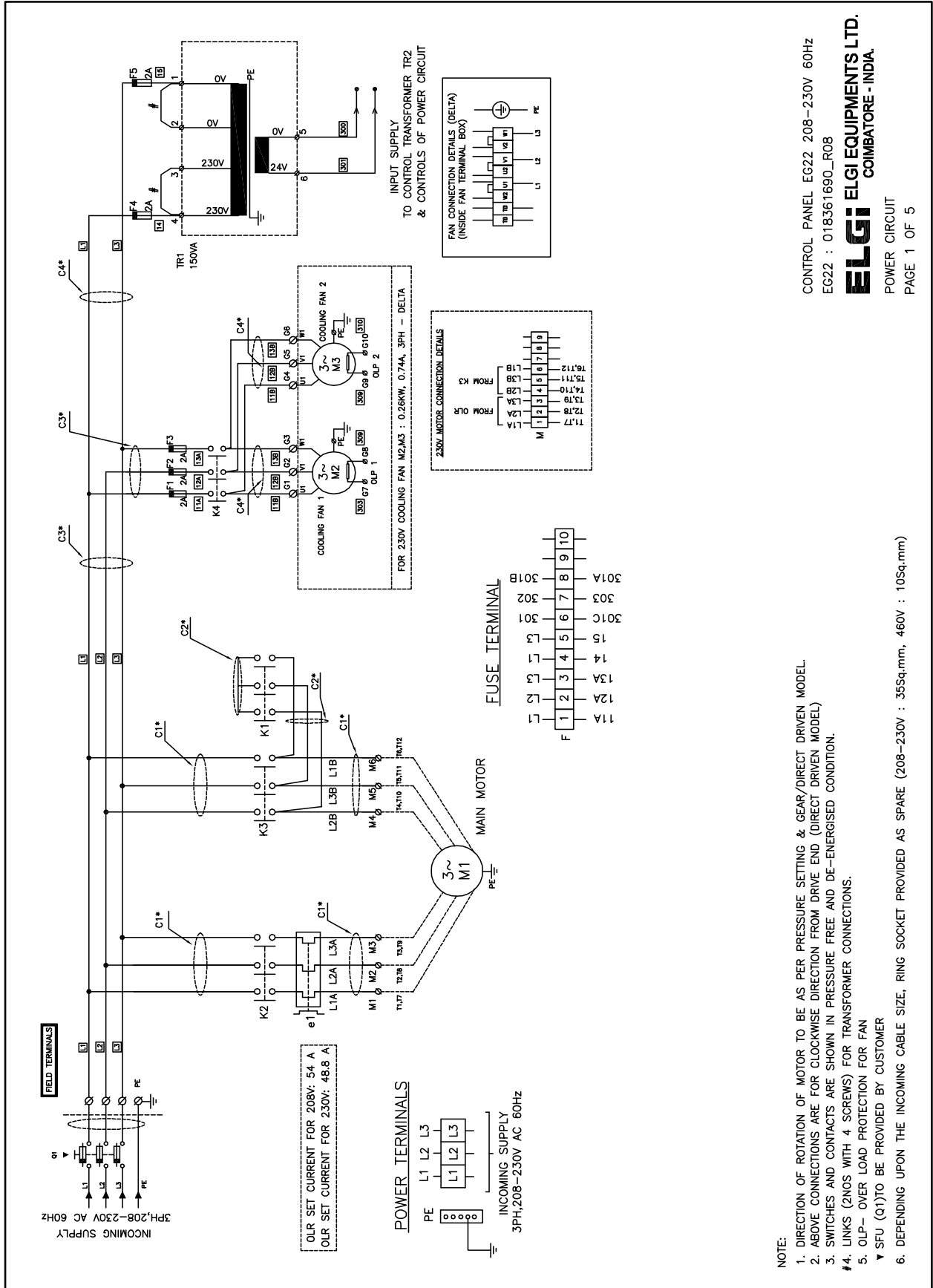

CONTROL PANEL EG22 208-230V 60HZ
EG22 : 018361690_R08
ELGI EQUIPMENTS LTD.
COIMBATORE - INDIA
POWER CIRCUIT
PAGE 1 OF 5

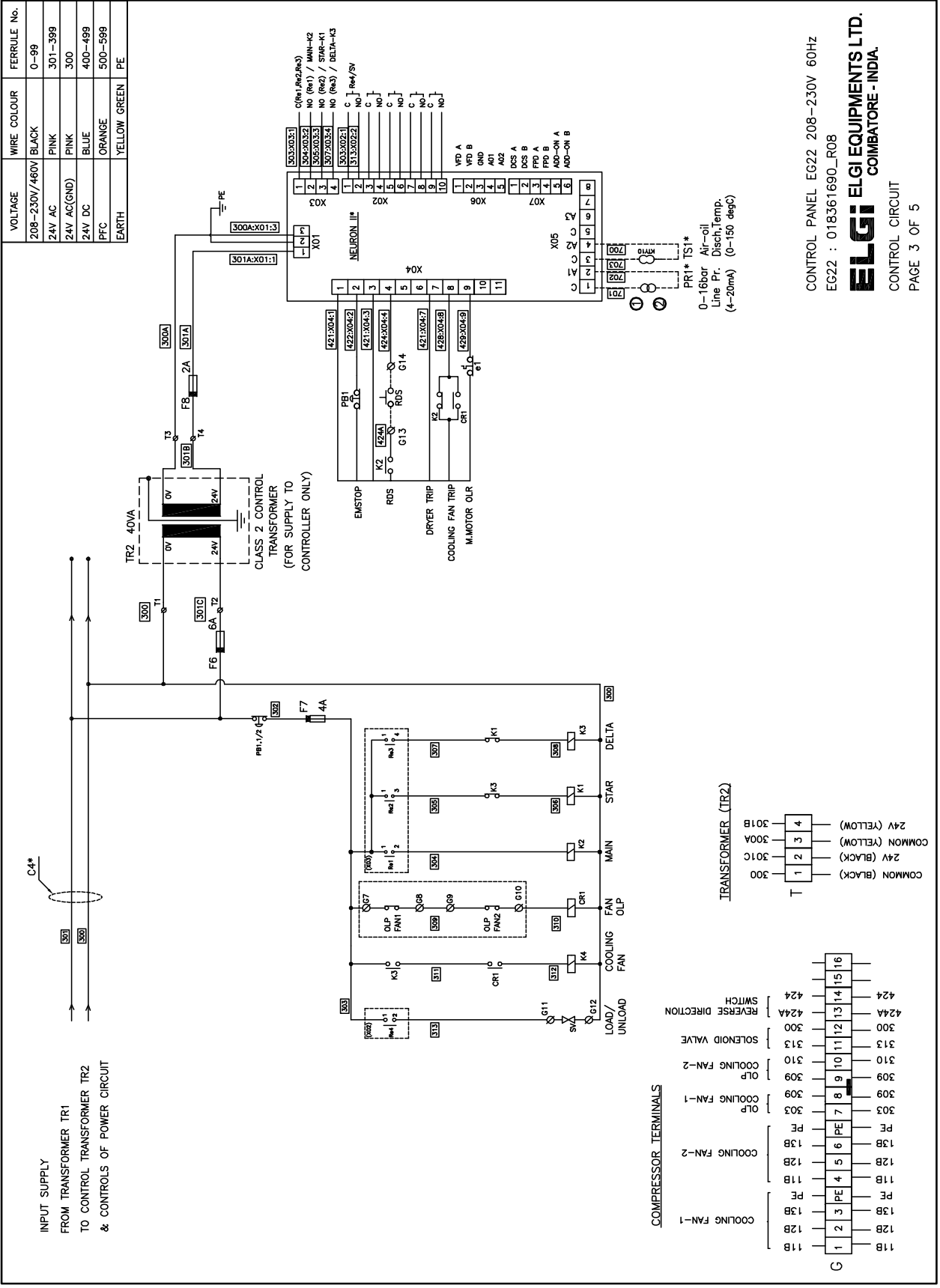

VOLTAGE	WIRE COLOUR	FERRULE No.
208-230V/460V	BLACK	0-99
24V AC	PINK	301-399
24V AC(GND)	PINK	300
24V DC	BLUE	400-499
PFC	ORANGE	500-599
EARTH	YELLOW GREEN	PE

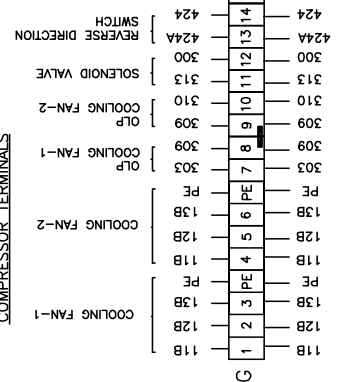
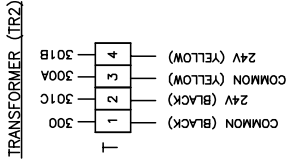

TS1*
0-16bar Air-oil Disch.Temp. Line Pr. (4-20mA) (0-150 degC)

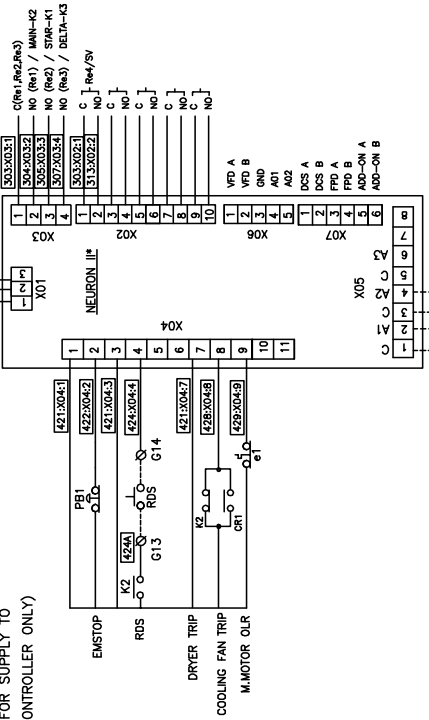

BILL OF MATERIAL

CODE	DESCRIPTION	MAKE	RATING	ELGI PART NO	QTY
K2-K3	POWER CONTACTOR (MAIN-DELTA)	SIEMENS	65A,3RT10 44-1AC20	008930107	2
K1	POWER CONTACTOR (STAR)	SIEMENS	50A,3RT10 36-1AC20	008930106	1
e1	OVERLOAD RELAY MAIN MOTOR	SIEMENS	25-100A, 3RB20 46-1EB0	018362636	1
K4	POWER CONTACTOR FOR COOLING FAN	SIEMENS	9A,3RT20 23-1AC20	008900170	1
TR1	MULTI TAP TRANSFORMER	PLITRON	150VA, 0-0-230V-230V/0-24V	00893703A	1
TR2	CONTROL TRANSFORMER 40VA	BASIC ELECTRICAL	40VA, 0-24V/0-24V	00893703C	1
CR1	CONTROL RELAY	PHOENIX	2961192	008946236	1
E-STOP	EMERGENCY STOP PUSH BUTTON	TEKNIC	P2AML4	008940030	1
INCOMING TB	TERMINAL BLOCK - PHASE	PHOENIX	UHV 50 WITH HOOD	00894642J	3
END CLAMP	TERMINAL BLOCK - END CLAMP	PHOENIX	-	00894642G	4
PE	EARTH STRIP FOR COMPONENT EARTH WITH 5mm SREW WITH FLAT & SPRING WASHER	-	COPPER WITH TIN COATING	-	1
G,T	CONTROL TERMINALS	WAGO	281-101	018362734	20
PE	CONTROL TERMINALS (YELLOW GREEN)	WAGO	281-107	018362733	2
F	FUSE TERMINALS	WAGO	281-611	018362735	10
-	GLASS FUSE 20 x 5	PROTECTRON	SLOW BLOW 2A	00894642A	-
-	GLASS FUSE 20 x 5	PROTECTRON	SLOW BLOW 4A	00894644A	-
-	GLASS FUSE 20 x 5	PROTECTRON	SLOW BLOW 6A	00894646A	-
N II	NEURON CONTROLLER	ELGI	-	00897701N	1
M	MOTOR CONNECTION TERMINALS	CONNECTWELL	CTS16U	008946320	9
CONNECTERS	PLC CONNECTER SET	PHOENIX	(3,4,5,6,8,10,11 PINS)	00897903R	1 SET
-	END STOPPER	WAGO	249-117	018362736	6
RDS	REVERSE DIRECTION SWITCH	WABCO	M250450	008941151	1
-	NO CONTACT FOR CONTACTOR	SIEMENS	3RH19 21-1CA10	008900380	2
-	NC CONTACT FOR CONTACTOR	SIEMENS	3RH19 21-1CA01	008900390	3
PT	PRESSURE TRANSMITTER	DANFOSS	-	00897902N	1
TT	TEMPERATURE TRANSMITTER	DANFOSS	-	00897902M	1

CABLE	SIZE (AWG)
208-230V	18KW
C1*	6
C2*	8
C3*	16
C4*	18

CONTROL PANEL EG22 208-230V 60HZ
EG22 : 018361690_R08

ELGI ELGI EQUIPMENTS LTD.
COIMBATORE - INDIA.

BILL OF MATERIALS
PAGE 4 OF 5

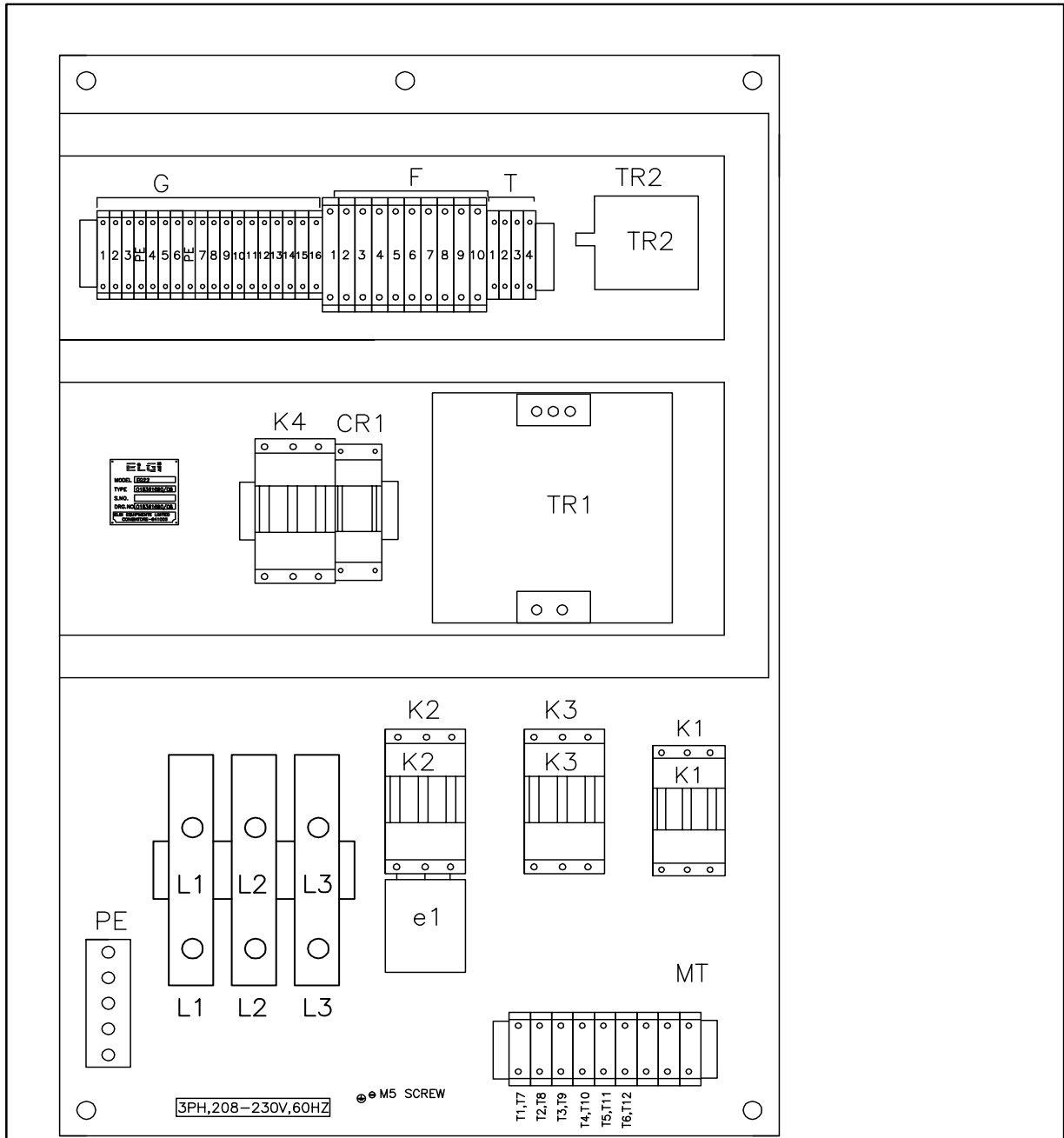

NOTE:

FOR BASE PLATE REFER LATEST REVISION DRAWING No. – 018361216

CONTROL PANEL EG22 208-230V 60Hz
EG22 : 018361690_R08

ELGI ELGI EQUIPMENTS LTD.,
COIMBATORE - INDIA.

PANEL LAYOUT
PAGE 5 OF 5

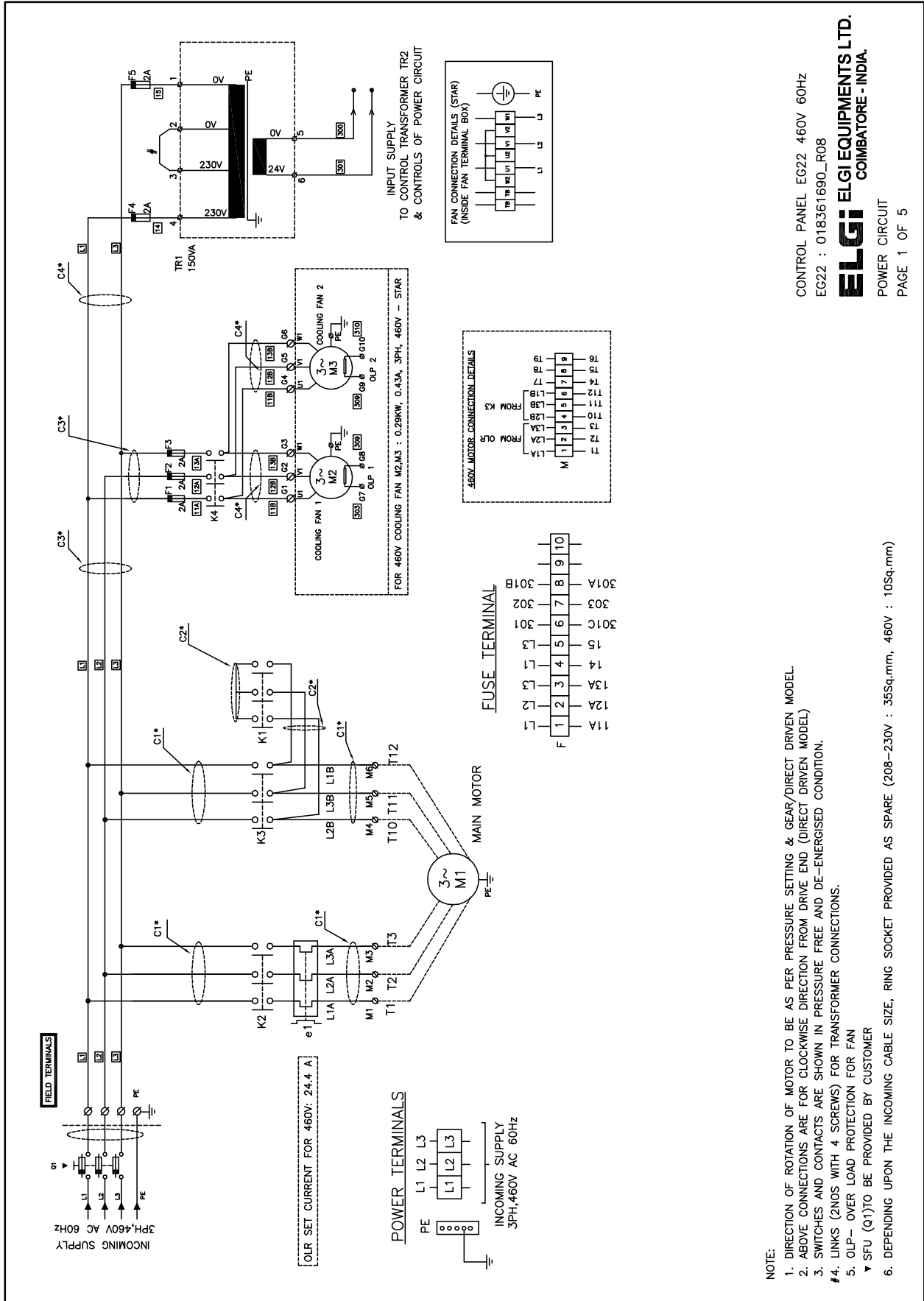

CONTROL PANEL EG22 460V 60Hz
EG22 : 018361690_R08

ELGI ELGI EQUIPMENTS LTD.
COIMBATORE - INDIA.

POWER CIRCUIT
PAGE 1 OF 5

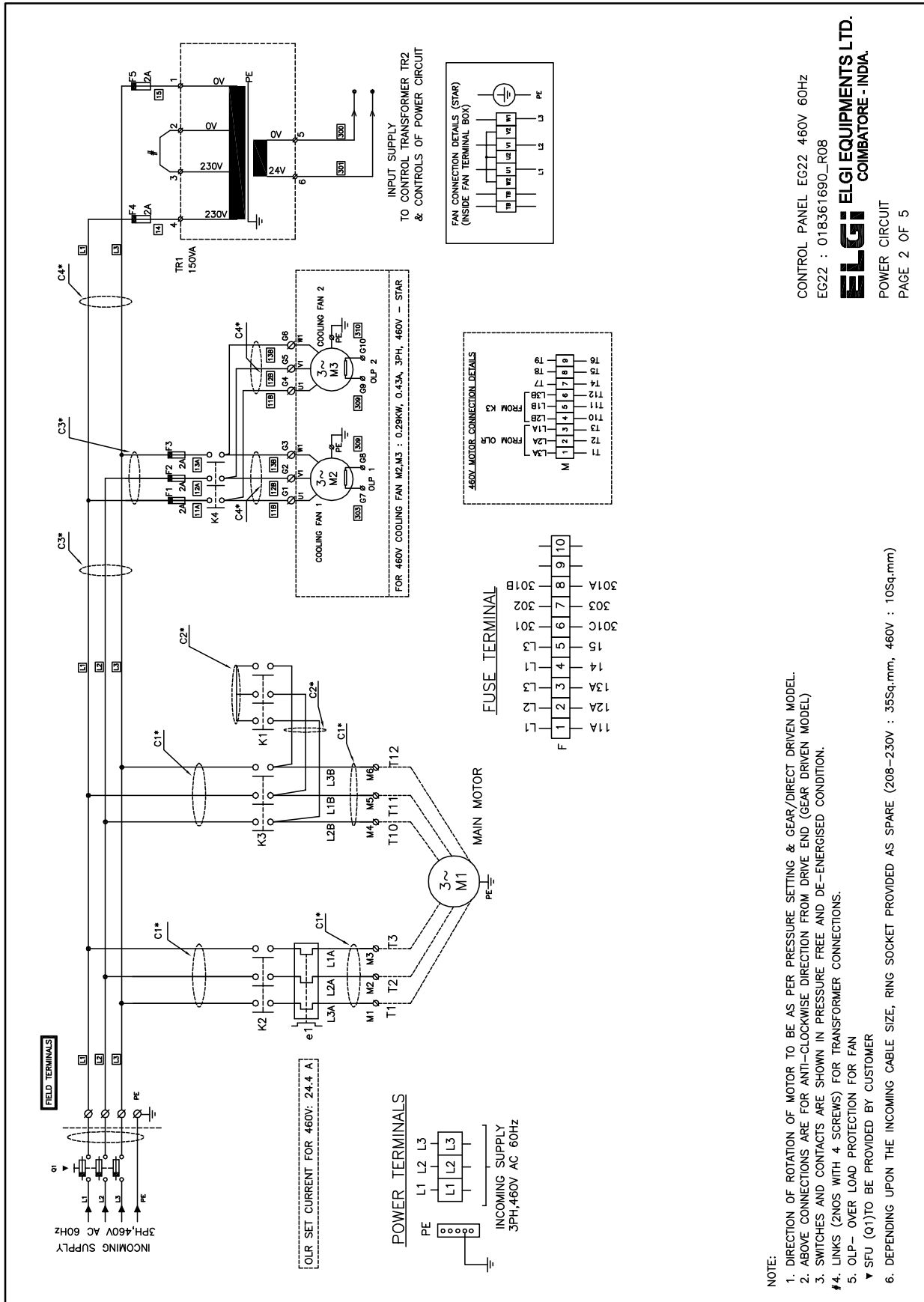

CONTROL PANEL EG22 460V 60HZ
EG22 : 018361690_R08
ELGI ELGI EQUIPMENTS LTD.
COIMBATORE - INDIA.
POWER CIRCUIT
PAGE 2 OF 5

BILL OF MATERIAL

CODE	DESCRIPTION	MAKE	RATING	ELGI PART NO	QTY
K2-K3	POWER CONTACTOR (MAIN-DELTA)	SIEMENS	65A,3RT10 44-1AC20	008930107	2
K1	POWER CONTACTOR (STAR)	SIEMENS	50A,3RT10 36-1AC20	008930106	1
e1	OVERLOAD RELAY MAIN MOTOR	SIEMENS	25-100A, 3RB20 46-1EB0	018362636	1
K4	POWER CONTACTOR FOR COOLING FAN	SIEMENS	9A,3RT20 23-1AC20	008900170	1
TR1	MULTI TAP TRANSFORMER	PLITRON	150VA, 0-0-230V-230V/0-24V	00893703A	1
TR2	CONTROL TRANSFORMER 40VA	BASIC ELECTRICAL	40VA, 0-24V/0-24V	00893703C	1
CR1	CONTROL RELAY	PHOENIX	2961192	008946236	1
E-STOP	EMERGENCY STOP PUSH BUTTON	TEKNIC	P2AML4	008940030	1
INCOMING TB	TERMINAL BLOCK - PHASE	PHOENIX	UHV 50 WITH HOOD	00894642J	3
END CLAMP	TERMINAL BLOCK - END CLAMP	PHOENIX	-	00894642G	4
PE	EARTH STRIP FOR COMPONENT EARTH WITH 5mm SREW WITH FLAT & SPRING WASHER	-	COPPER WITH TIN COATING	-	1
G,T	CONTROL TERMINALS	WAGO	281-101	018362734	20
PE	CONTROL TERMINALS (YELLOW GREEN)	WAGO	281-107	018362733	2
F	FUSE TERMINALS	WAGO	281-611	018362735	10
-	GLASS FUSE 20 x 5	PROTECTRON	SLOW BLOW 2A	00894642A	-
-	GLASS FUSE 20 x 5	PROTECTRON	SLOW BLOW 4A	00894644A	-
-	GLASS FUSE 20 x 5	PROTECTRON	SLOW BLOW 6A	00894646A	-
N II	NEURON CONTROLLER	ELGI	-	00897701N	1
M	MOTOR CONNECTION TERMINALS	CONNECTWELL	CTS16U	008946320	9
CONNECTERS	PLC CONNECTER SET	PHOENIX	(3,4,5,6,8,10,11 PINS)	00897903R	1 SET
-	END STOPPER	WAGO	249-117	018362736	6
RDS	REVERSE DIRECTION SWITCH	WABCO	M250450	008941151	1
-	NO CONTACT FOR CONTACTOR	SIEMENS	3RH19 21-1CA10	008900380	2
-	NC CONTACT FOR CONTACTOR	SIEMENS	3RH19 21-1CA01	008900390	3
PT	PRESSURE TRANSMITTER	DANFOSS	-	00897902N	1
TT	TEMPERATURE TRANSMITTER	DANFOSS	-	00897902M	1

CABLE	SIZE (AWG)
208-230V	18KW
C1*	6
C2*	8
C3*	16
C4*	18

CONTROL PANEL EG22 460V 60HZ
EG22 : 018361690_R08

ELGI ELGI EQUIPMENTS LTD.
COIMBATORE - INDIA.

BILL OF MATERIALS
PAGE 4 OF 5

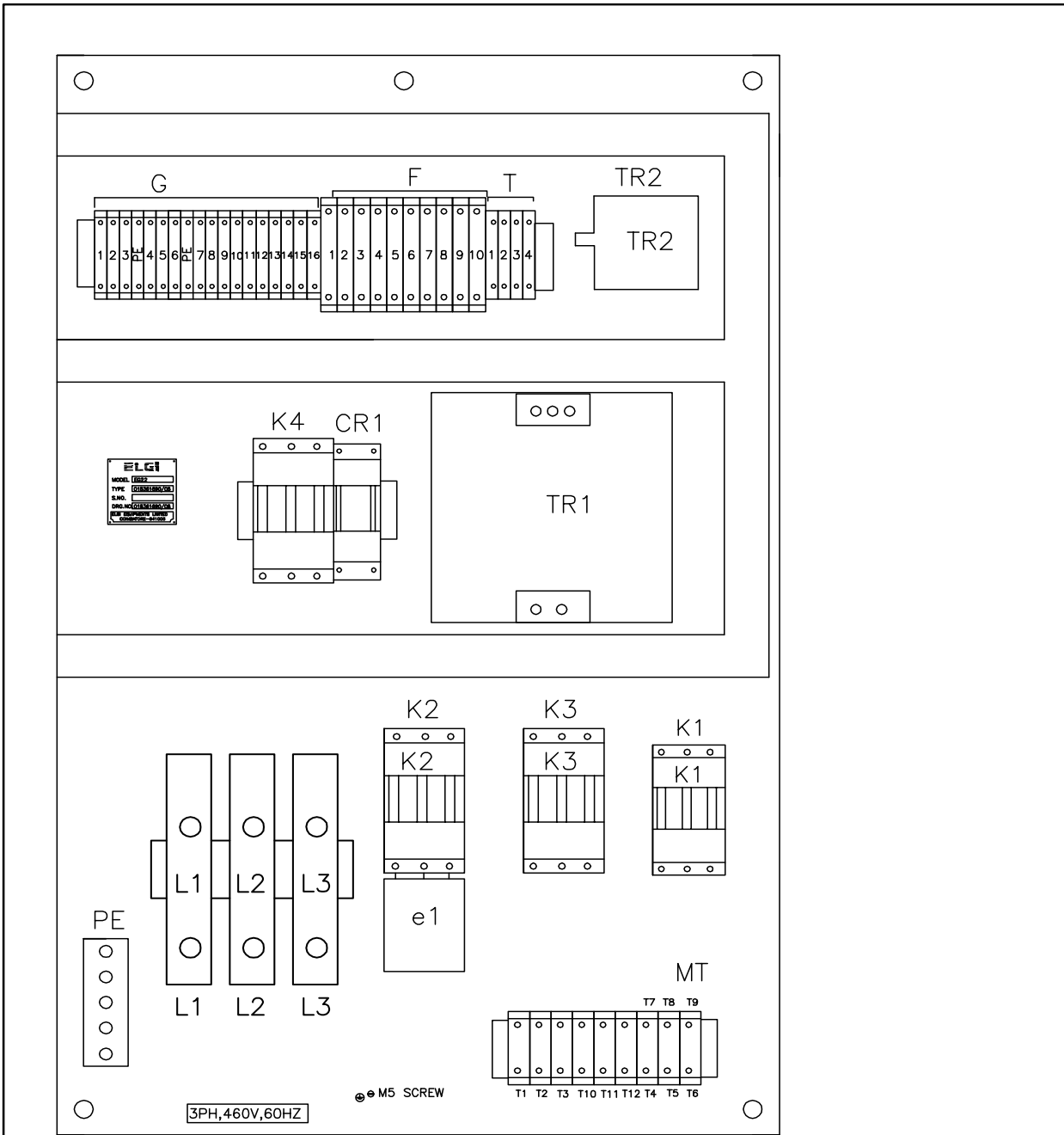

NOTE:

FOR BASE PLATE REFER LATEST REVISION DRAWING No. – 018361216

CONTROL PANEL EG22 460V 60Hz

EG22 : 018361690_R08

ELGI ELGI EQUIPMENTS LTD.,
COIMBATORE - INDIA.

PANEL LAYOUT

PAGE 5 OF 5

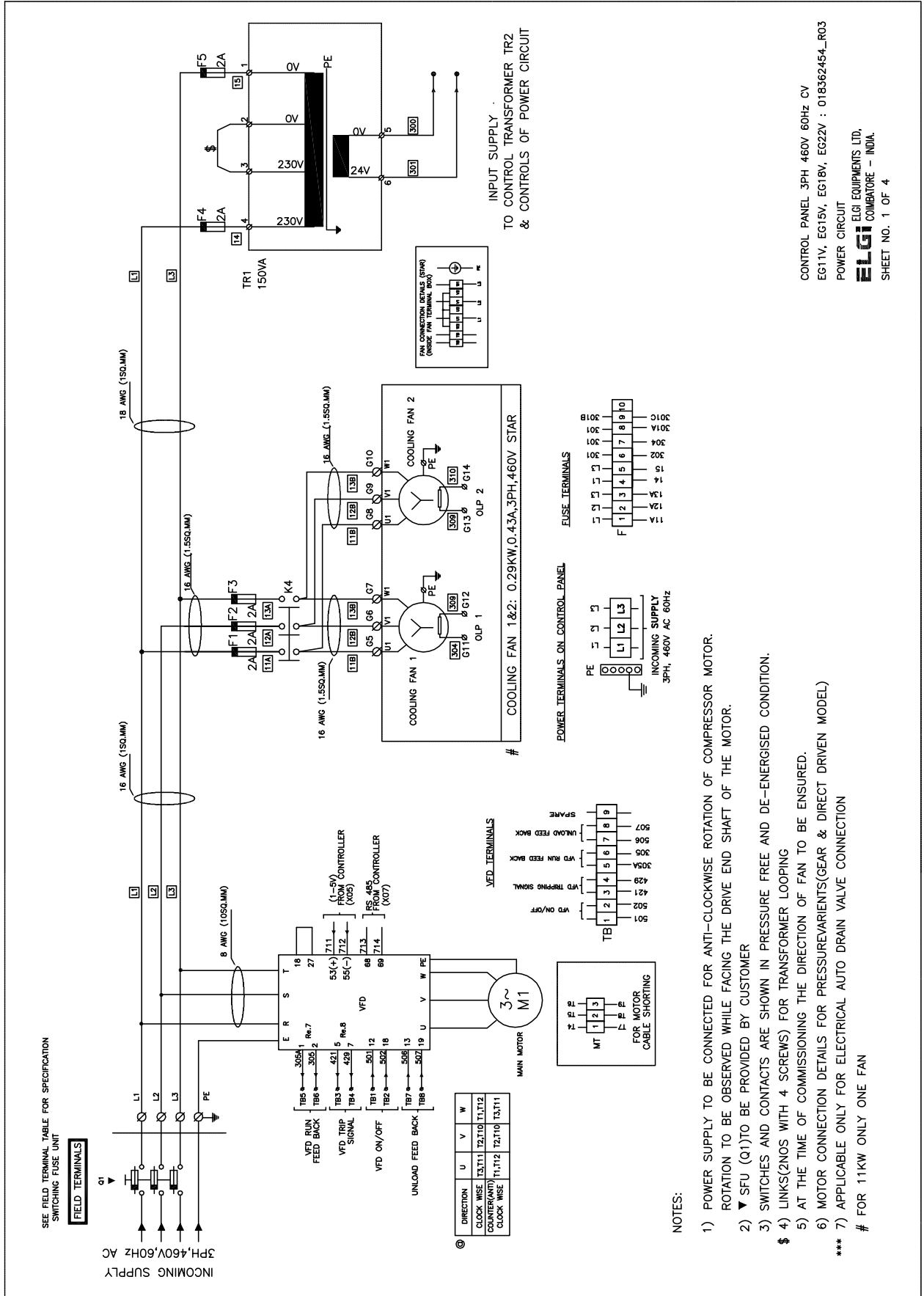

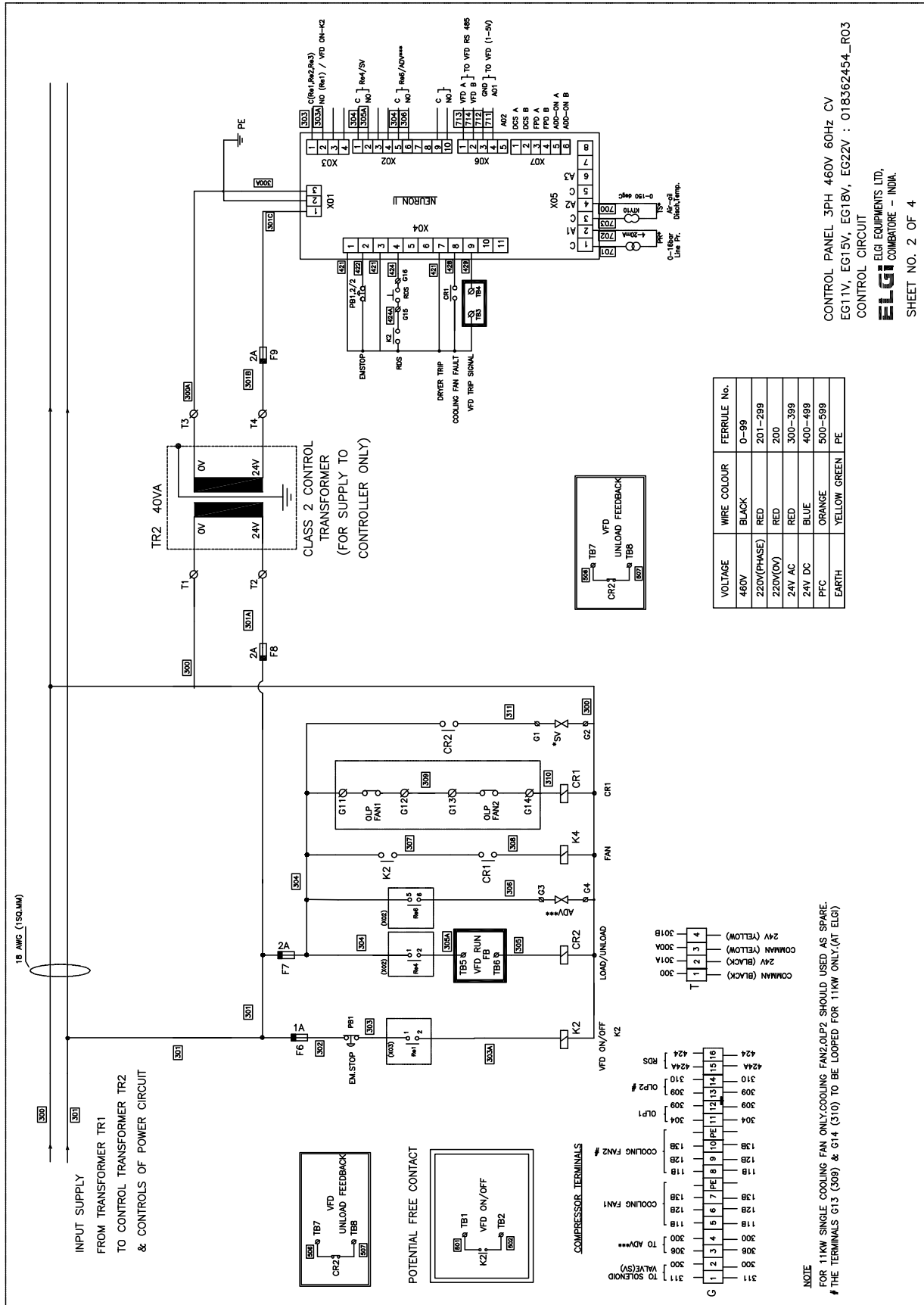

VOLTAGE	WIRE COLOUR	FERRULE No.
460V	BLACK	0-99
220V(PHASE)	RED	201-299
220V(OV)	RED	200
24V AC	RED	300-399
24V DC	BLUE	400-499
PFC	ORANGE	500-599
EARTH	YELLOW GREEN	PE

Terminal	Wire Colour	Ferrule No.
301A	BLACK	300
301B	YELLOW	24V

NOTE
FOR 11KW SINGLE COOLING FAN ONLY. COOLING FAN2, OLP2 SHOULD BE USED AS SPARE.
THE TERMINALS G13 (309) & G14 (310) TO BE LOOPED FOR 11KW ONLY. (AT ELG)

CONTROL PANEL 3PH 460V 60Hz CV
EG11V, EG15V, EG18V, EG22V : 018362454_R03
CONTROL CIRCUIT
ELGI COMBATORE - INDIA
SHEET NO. 2 OF 4

BILL OF MATERIALS

CODE	DESCRIPTION	RATING	ELGI PART NO
L1-L3	INCOMING TERMINALS	RBO-6FEO WITH COVER	008932069
VFD	DRIVE (ELGI SCOPE)	11KW (15HP)	B012000510023
	DRIVE (ELGI SCOPE)	15KW (20HP)	B012000510024
	DRIVE (ELGI SCOPE)	18.5KW (25HP)	B012000510025
	DRIVE (ELGI SCOPE)	22KW (30HP)	B012000510019
K2	CONTROL CONTACTOR	3RH21 31-1AB00,10A,24 V AC	018362749
K4	FAN CONTACTOR	3RT20 16 -1AB01,9A,24 V AC	008900130
CR1,CR2	CONTROL RELAY	2961192	008946236
TR1	MULTI TAP TRANSFORMER	150VA 0-0-230-230V/0-24V	00893703A
TR2	CONTROL TRANSFORMER	40VA,0-24/0-24V	00893703C
G,TB,T	CONNECTING TERMINALS	281-101	018362734
PE	CONNECTING TERMINALS (Y/G)	281-107	018362733
MT	MOTOR CONNECTING TERMINALS	CTS10U	008946220
F	FUSE TERMINALS WITH GLASS FUSE	281-611	018362735
-	GLASS FUSE	SLOW BLOW,1A	00894641A
-	GLASS FUSE	SLOW BLOW,2A	00894642A
N II	NEURON CONTROLLER	-	00897701N
E-STOP	EMERGENCY STOP PUSH BUTTON	2AMPP4 2S2	008940030
PE	EARTH BAR	-	-
RDS	REVERSE DIRECTION SWITCH	M250 450	008941151
PT	PRESSURE TRANSMITTER	MBS1900	00897902N
TS	TEMPERATURE SENSOR	KTY10	00897902M

CONTROL PANEL 3PH 460V 60Hz CV

EG11V, EG15V, EG18V, EG22V : 018362454_R03

ELGI ELGI EQUIPMENTS LTD,
COIMBATORE - INDIA.

BILL OF MATERIALS

SHEET NO. 3 OF 4

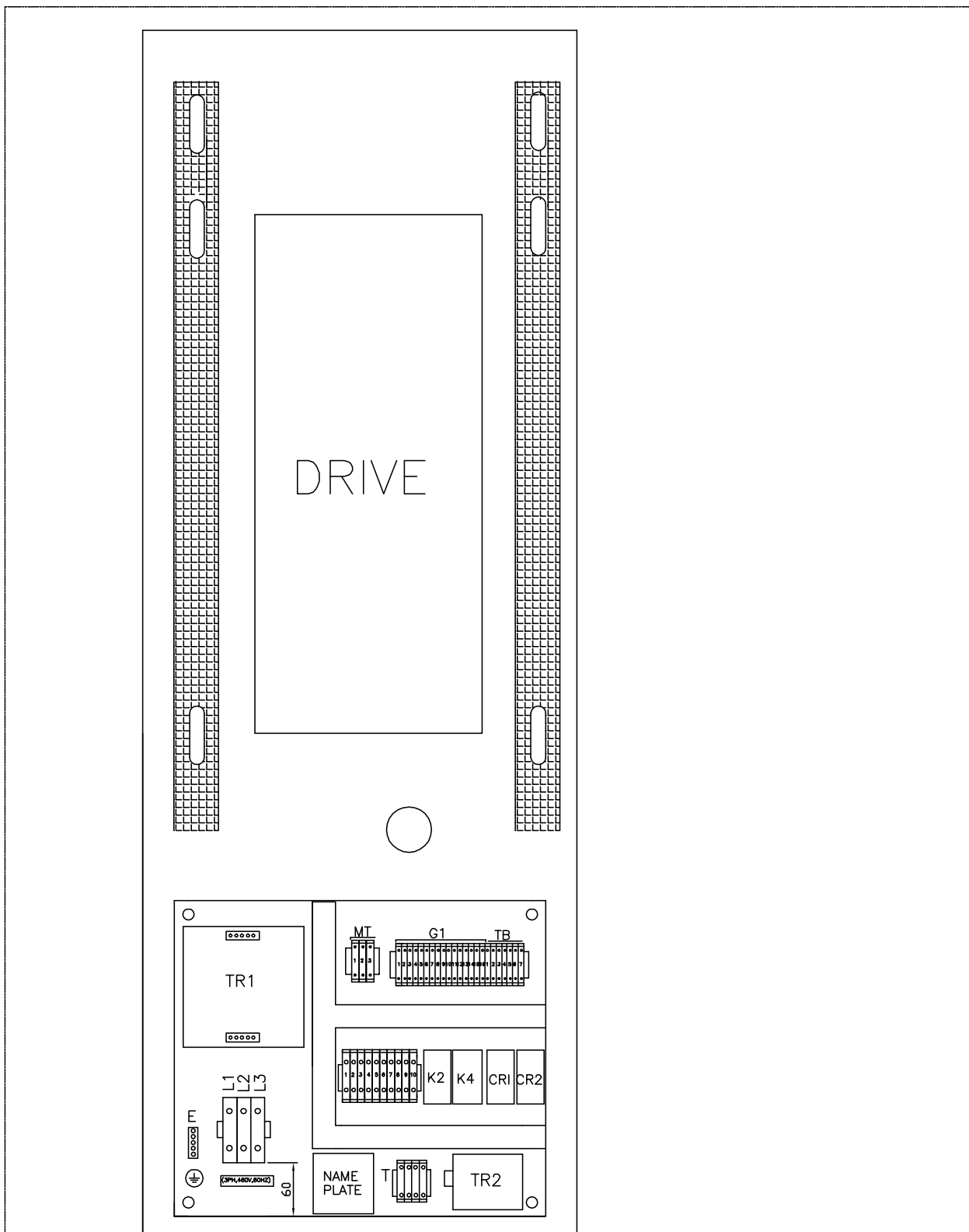

NOTE :
FOR BASE PLATE REFER - 018360650

CONTROL PANEL 3PH 460V 60Hz CV
EG11V, EG15V, EG18V, EG22V : 018362454_R03

ELGI ELGI EQUIEMENTS LTD,
COIMBATORE - INDIA.
PANEL LAYOUT
SHEET NO. 4 OF 4

LEGEND

101		AIR FILTER
102		CHOKE INDICATOR
103		INTAKE VALVE (NC)
104		AIREND
105		AIR OIL SEPARATOR TANK
106		AIR OIL SEPARATOR
107		MINIMUM PRESSURE VALVE
108		AFTER COOLER
109		SAFETY VALVE
110		THERMAL VALVE
111		OIL COOLER
112		OIL FILTER
113		MOISTURE SEPARATOR (AUTO DRAIN)
114		OIL DRAIN VALVE
115		BLOWDOWN VALVE (NO)
116		SOLENOID VALVE (NC)
117		DRIVE COUPLING
118		BALL VALVE

P & I DRAWING

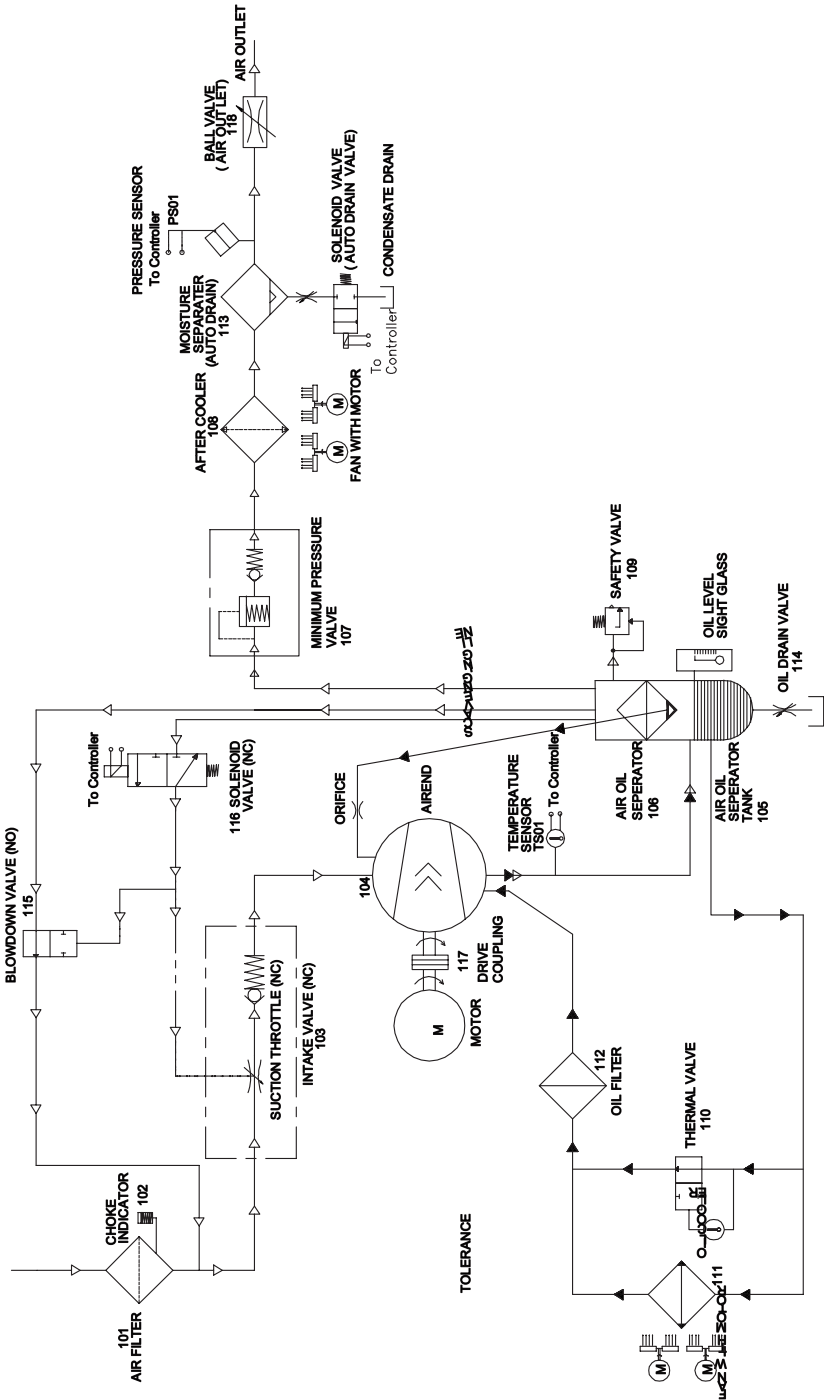

LEGEND		PIPE SIZE
	Envelope line	-
	Air Line	1 1/2 inch
	Pulse Line	6 mm
	Oil Line	3/4 inch
	Air Oil Line	1 inch

INSTRUMENTS TAG No.		DESCRIPTION
TS01		TEMPERATURE SENSOR
PS01		PRESSURE SENSOR

DECALS F2 US

ELGi

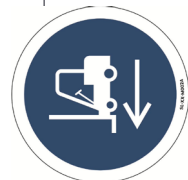
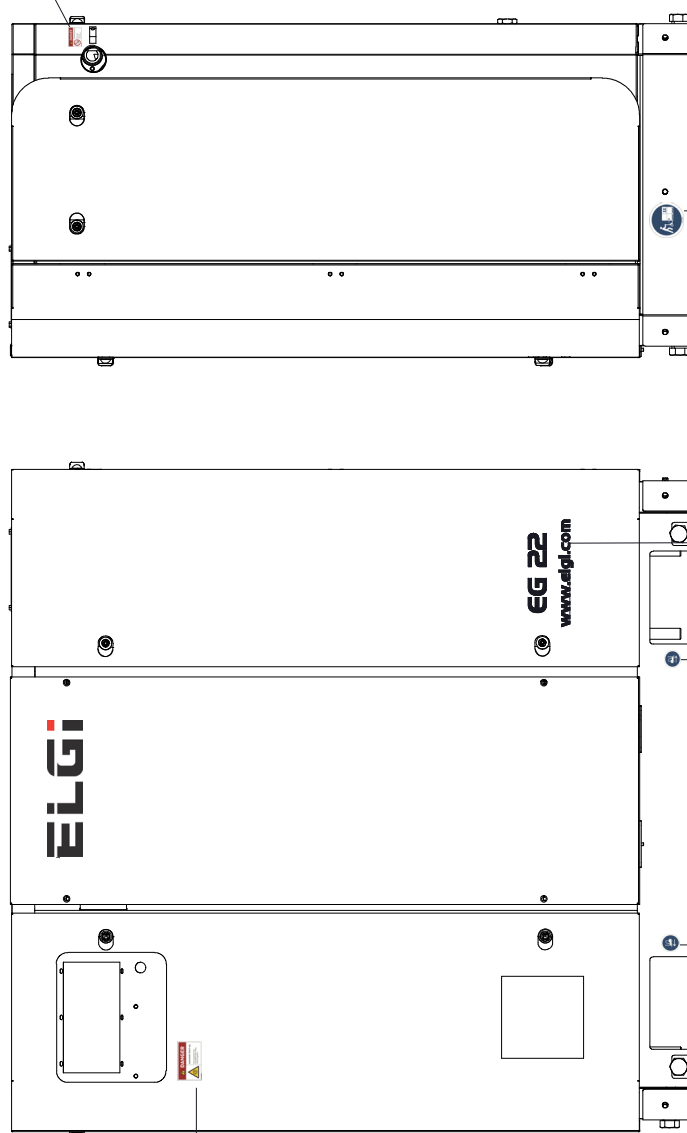

EG 22

www.elgi.com

• MODEL STICKER FOR REFERENCE ONLY

DECALS F2 US

NOTICE

Maintenance Instructions.

Maintenance Activity	Frequency / Cleaning Interval	Output Interval
1. Fan Filter	1000	2000
2. Mainframe Drive	1000	X
3. Cabinet Ventilation	1000	X
4. Cabinet Connections	4000	X
5. Motor Grounding	10 to 25 hrs	X
6. Motor Grounding	10 to 300 hrs	X
7. Air Filter Element	X	4000
8. Separator Element	X	8000
9. Oil - All Units U.S. Sign	X	8000

NOTE: X indicates that the activity is required for the equipment. For more information on maintenance, refer to the maintenance manual.

NOTICE

Daily Checks

- Hourmeter reading
- Discharge temperature
- Load & Inload pressure
- Air filter clog indicator
- Compressor oil level
- Motor run trap drain
- Motor run trap drain

DANGER

Hot Surface.
Contact can cause severe burn injury. Do not touch.

NOTICE

Electrical cable Entry Point.
Do not connect or disconnect any equipment to this equipment.

CAUTION

Read Manual.
Read instruction manual before start of operations with the equipment.

DANGER

Hazardous Voltage.
Improper use of equipment may cause severe injury or death.

CAUTION

Connect Correctly.
Improper connection, loose connections, wrong connection may cause severe injury or death.

CAUTION

Check Direction of Rotation.
Improper rotation may damage equipment or cause injury.

DANGER

Hazardous Voltage.
Improper use of equipment may cause severe injury or death.

CAUTION

Remove Vibration
Vibration emitting clamps can cause damage to the equipment.

DANGER

Crush Hazard.
Moving parts can crush keep hands clear.

CAUTION

For Direct drive Models Counter Clock Wise

CAUTION

For Gear Drive models Clock Wise

CONTROL PANEL DOOR OPEN SIDE VIEW

CONTROL PANEL DOOR OPEN VIEW

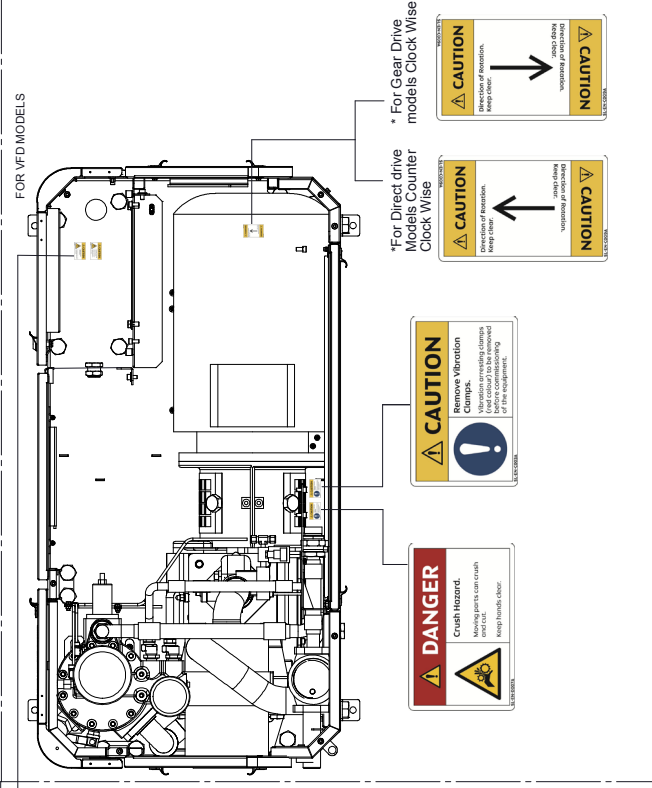

DECALS F2 US

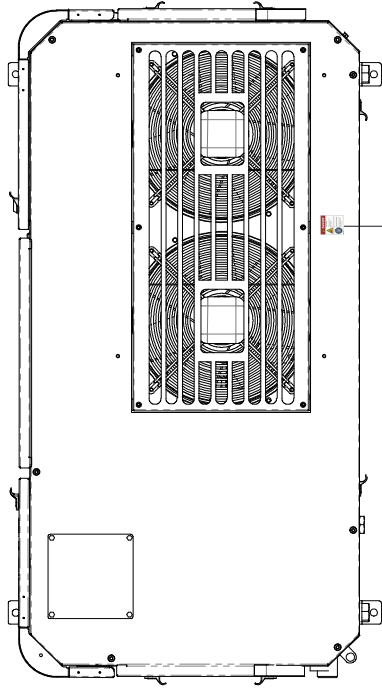
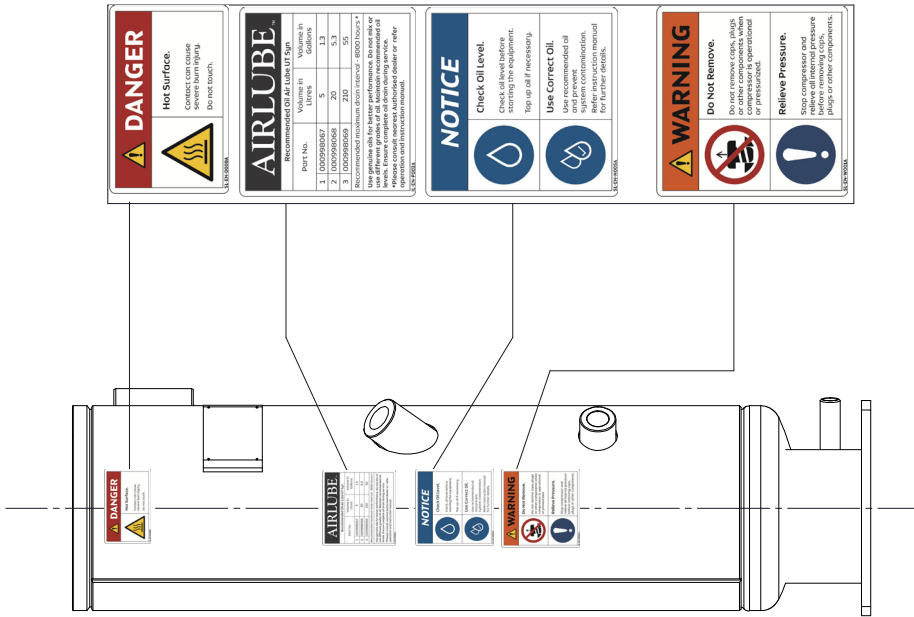

DANGER

Cut Hazard.
The sharp edges of the machine and parts can cause severe injury.
Keep hands and body clear.

Ensure Fan Guards.
The fan is in operation in place before starting the equipment.

U10120001

TANK ASSEMBLY

Disclaimers

Please read this document and the warranty terms accompanying the product carefully before using our product. By purchasing our product, you agree that you will assume total responsibility and risk for your use of the product. The warranty terms of the product have been provided separately.

1. ELGi is not liable for failure of the compressor (hereinafter “compressor” or “product”) to perform its obligations if such failure is as a result of Acts of God (including but not limited to fire, flood, earthquake, storm, hurricane or other natural disaster), war, invasion, act of foreign enemies, hostilities (regardless of whether war is declared), civil war, rebellion, revolution, insurrection, military or usurped power or confiscation, terrorist activities, nationalization, government sanction, blockage, embargo, labor dispute, strike, lockout or interruption or failure of electricity or telephone service and any other reasons beyond ELGi’s control.
2. ELGi does not take responsibility for any damage or injury resulting from neglecting the safety instructions, warnings, cautions, precautions, or non-observance of the normal caution and care required for installation, operation, maintenance and repair of the product, even if not expressly stated, and such instances are specifically disclaimed by ELGi.
3. The entire literature including product description or any other information in this manual exclusively belongs to ELGi and is subject to copyright. No person has any right to copy, modify, distribute, transmit, display, perform, reproduce, publish, license, create derivative works, transfer or sell any information, or deal with the same in any other manner, without the knowledge and written concurrence of ELGi, violation of which would amount to infringement of rights of ELGi and would necessitate legal action.
4. The information published in this manual may include inaccuracies, or typographical errors. Changes may be periodically added to the information herein. Any changes/improvements may also be made to the products stated in this manual and ELGi is not liable if the readers are not updated with information.
5. Likewise ELGi is responsible only till the point of first sale to the ultimate customer and not thereafter and only if the product is purchased from authorized dealers of ELGi. ELGi disowns liability on account of purchase of any second hand product or purchase otherwise from unauthorized dealers. ELGi shall not be liable for any indirect, incidental, punitive, special or consequential losses or damages including any loss of profit, loss of production, loss of income or contract, loss of goodwill, expected savings or business relationships, arising out of or in any way connected with the usage of the product or information in this manual.
6. In no event ELGi shall be liable for any claims or loss having a value higher than the original purchase price of the product sold by ELGi or its network of authorised dealers.
7. These Disclaimers and the contents of this manual shall be subject to the laws of India and any disputes pertaining to this manual or anything stated therein or any product stated therein is subject to the exclusive jurisdiction of the courts in Coimbatore, Tamilnadu, India.
8. No liability in connection with the product will accrue to ELGi,
 - * If any welding or related operation involving heat is carried out in the compressor. Never weld or modify any parts including pressure vessels.
 - * If any damages to the product directly or indirectly arise due to long storage (6 months) of product and subsequent corrosion of internal parts and which leads to fire or malfunctioning of the product.
 - * If the compressor package and its accessories are installed in such a way to allow moisture, rain, freezing temperature or sun damage to affect the safe operation of the unit.
 - * If the person who operates / maintains the compressor does not adhere to all work related safety practices and regulatory requirements.
 - * If unauthorized personnel other than ELGi authorized or trained personnel carries out commissioning, installation, operation, maintenance and any repair work on the compressor.
 - * If the compressor and the compressed air are used for unintended use or are misused.
 - * If the compressor is operated below or in excess of its pressure and temperature limits.
 - * If the compressor “ON/ OFF” switch is operated through remote control situated away from the compressor location without giving any adequate notice / alarm before starting the product .

(C) Copyright ELGi Equipments Limited, India 2014. All Rights Reserved.

Disclaimers

Please read this document and the warranty terms accompanying the product carefully before using our product. By purchasing our product, you agree that you will assume total responsibility and risk for your use of the product. The warranty terms of the product have been provided separately.

1. ELGi is not liable for failure of the compressor (hereinafter “compressor” or “product”) to perform its obligations if such failure is as a result of Acts of God (including but not limited to fire, flood, earthquake, storm, hurricane or other natural disaster), war, invasion, act of foreign enemies, hostilities (regardless of whether war is declared), civil war, rebellion, revolution, insurrection, military or usurped power or confiscation, terrorist activities, nationalization, government sanction, blockage, embargo, labor dispute, strike, lockout or interruption or failure of electricity or telephone service and any other reasons beyond ELGi’s control.
2. ELGi does not take responsibility for any damage or injury resulting from neglecting the safety instructions, warnings, cautions, precautions, or non-observance of the normal caution and care required for installation, operation, maintenance and repair of the product, even if not expressly stated, and such instances are specifically disclaimed by ELGi.
3. The entire literature including product description or any other information in this manual exclusively belongs to ELGi and is subject to copyright. No person has any right to copy, modify, distribute, transmit, display, perform, reproduce, publish, license, create derivative works, transfer or sell any information, or deal with the same in any other manner, without the knowledge and written concurrence of ELGi, violation of which would amount to infringement of rights of ELGi and would necessitate legal action.
4. The information published in this manual may include inaccuracies, or typographical errors. Changes may be periodically added to the information herein. Any changes/improvements may also be made to the products stated in this manual and ELGi is not liable if the readers are not updated with information.
5. Likewise ELGi is responsible only till the point of first sale to the ultimate customer and not thereafter and only if the product is purchased from authorized dealers of ELGi. ELGi disowns liability on account of purchase of any second hand product or purchase otherwise from unauthorized dealers. ELGi shall not be liable for any indirect, incidental, punitive, special or consequential losses or damages including any loss of profit, loss of production, loss of income or contract, loss of goodwill, expected savings or business relationships, arising out of or in any way connected with the usage of the product or information in this manual.
6. In no event ELGi shall be liable for any claims or loss having a value higher than the original purchase price of the product sold by ELGi or its network of authorised dealers.
7. These Disclaimers and the contents of this manual shall be subject to the laws of India and any disputes pertaining to this manual or anything stated therein or any product stated therein is subject to the exclusive jurisdiction of the courts in Coimbatore, Tamilnadu, India.
8. No liability in connection with the product will accrue to ELGi,
 - * If any welding or related operation involving heat is carried out in the compressor. Never weld or modify any parts including pressure vessels.
 - * If any damages to the product directly or indirectly arise due to long storage (6 months) of product and subsequent corrosion of internal parts and which leads to fire or malfunctioning of the product.
 - * If the compressor package and its accessories are installed in such a way to allow moisture, rain, freezing temperature or sun damage to affect the safe operation of the unit.
 - * If the person who operates / maintains the compressor does not adhere to all work related safety practices and regulatory requirements.
 - * If unauthorized personnel other than ELGi authorized or trained personnel carries out commissioning, installation, operation, maintenance and any repair work on the compressor.
 - * If the compressor and the compressed air are used for unintended use or are misused.
 - * If the compressor is operated below or in excess of its pressure and temperature limits.
 - * If the compressor “ON/ OFF” switch is operated through remote control situated away from the compressor location without giving any adequate notice / alarm before starting the product .

(C) Copyright ELGi Equipments Limited, India 2014. All Rights Reserved.

6	5	4	3	2	1
CAD FILE NAME : 018362454					
BILL OF MATERIALS					
CODE	DESCRIPTION	MAKE	RATING	ELGI PART NO.	QTY
L1-L3	INCOMING TERMINALS	PHOENIX	RSC-6FEO WITH COVER	008932070	3
VFD	DRIVE	DANFOSS	11KW (15HP) 15KW (20HP) 18KW (25HP) 22KW (30HP)	B012000510023 B012000510024 B012000510025 B012000510019	1
K2	CONTROL CONTACTOR	SIEMENS	10A, 3RH21 31-1AB00	018362749	1
K4	FAN CONTACTOR	SIEMENS	9A, 3RT20 16-1AB01	008900130	1
CR1	CONTROL RELAY	PHOENIX	2961192	008946236	1
TR1	MULTI TAP TRANSFORMER	PLITRON	150VA 0-0-230-230V/0-24V	00893703A	1
TR2	CONTROL TRANSFORMER	BASIC ELECTRICAL	40VA,0-24/0-24V	00893703C	1
G,T	CONNECTING TERMINALS	WAGO	281-101	018362734	18
PE	CONNECTING TERMINALS (Y/G)	WAGO	281-107	018362736	2
MT	MOTOR CONNECTING TERMINALS	CONNECTWELL	CTS10U	008946220	3
F	FUSE TERMINALS WITH GLASS FUSE	WAGO	281-611	018362735	12
-	GLASS FUSE	PROTECTRON	1A, SLOW BLOW	00894641A	-
-	GLASS FUSE	PROTECTRON	2A, SLOW BLOW	00894642A	-
-	GLASS FUSE	PROTECTRON	4A, SLOW BLOW	00894644A	-
-	GLASS FUSE	PROTECTRON	6.3A, SLOW BLOW	00894646A	-
N III	NEURON CONTROLLER	ELGI	-	X0180912	1
E-STOP	EMERGENCY STOP PUSH BUTTON	TEKNIC	P2AML4	008940030	1
PE	EARTH STRIP FOR COMPONENT EARTH WITH 5mm SCREW WITH FLAT & SPRING WASHER	-	COPPER WITH TIN COATING	-	1
CONNECTER	PLC CONNECTER SET	WAGO	231-102/026-000 713-1105 713-1106 713-1104 231-204/026-000 231-206/026-000 231-203/026-000 231-108/026-000	018400109	1 SET
PS1	PRESSURE TRANSMITTER	DANOSS	-	00897902N	1
TS1	TEMPERATURE SENSOR	DANOSS	PT1000	018400078	1

ITEM NO.	DESCRIPTION	QTY	DRAWING No.	REV.	REMARKS
MODEL	CONTROL PANEL EG11-22V 460V 60HZ				
MAT'L					
DESIGNED	NAME	DATE	RPP.DRG.No.		
CAD	CS	01.11.12	SCALE	NEXT ASSY.	
CHECKED	JAY	01.11.12	NTS	DRG.No. 01 83 6245 4	
APPD.			DRG.SHEET 3	OF 8	REVISION R 0 4

REV. NO.	ECO.No.	DATE	DESCRIPTION	ALT.BY.	CHD.BY.
6		5	4	3	2

BILL OF MATERIALS

ELGI ELGI EQUIPMENTS LTD.,
COIMBATORE - INDIA.

ALL DIMENSIONS ARE IN mm UNLESS OTHERWISE SPECIFIED. MACHINING DEVIATION FOR OPEN DIMS,IS 2102(Medium)>4000
 DIM/ TOLERANCE
 OVER 6 30 120 315 1000 2000 4000
 ±0.1 ±0.2 ±0.3 ±0.5 ±0.8 ±1.2 ±2 ±3
 VALUE IN μm
 ROUGHNESS SYMBOL N1 N2 N3 N4 N5 N6 N7 N8 N9 N10 N11 N12
 ROUGHNESS 0.05 0.1 0.2 0.4 0.8 1.6 3.2 6.3 12.5 25 50
 SURFACE FINISH SYMBOLS
 All information contained in this document is CONFIDENTIAL and the property of ELGI EQUIPMENTS LIMITED
 Reproduction of these in any form should only be done with the specific permission of the company.

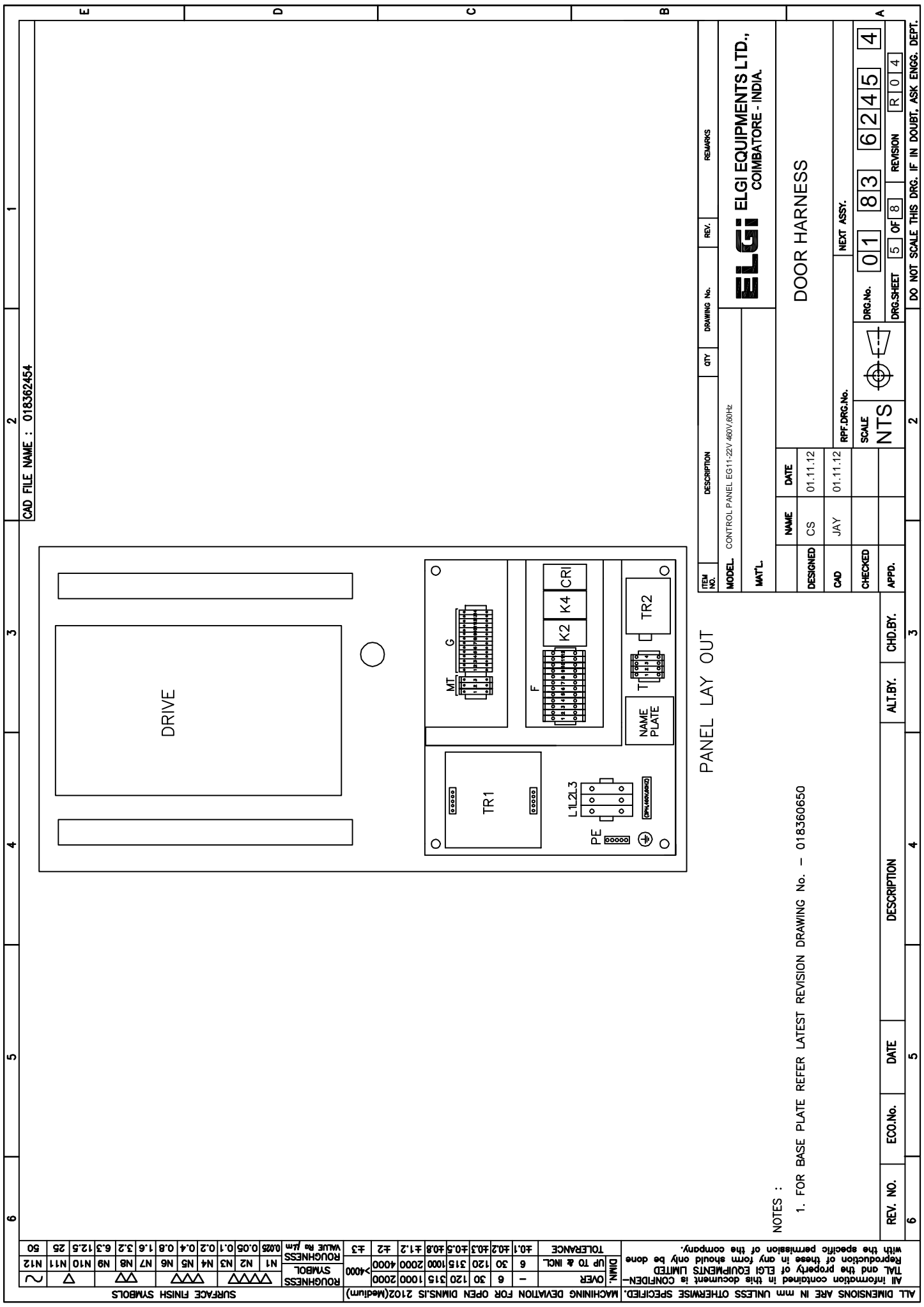

CAD FILE NAME : 018362454

PANEL LAY OUT

ITEM NO.	DESCRIPTION	QTY	DRAWING No.	REV.	REMARKS
MODEL	CONTROL PANEL EG111-22V.460V.60HZ				
MAT'L					
DESIGNED	NAME	DATE	ELGI ELGI EQUIPMENTS LTD., COIMBATORE - INDIA.		
CAD	CS	01.11.12	DOOR HARNESS		
CHECKED	JAY	01.11.12	NEXT ASSY.		
APPD.			SCALE NTS		
			DRG.No.	01	83
			DRG.SHEET	5	OF 8
			REVISION	R	0
					4

NOTES :
1. FOR BASE PLATE REFER LATEST REVISION DRAWING No. - 018360650

REV. NO.	ECO.No.	DATE	DESCRIPTION	ALT.BY.	CHD.BY.
6		5			3

DO NOT SCALE THIS DRG. IF IN DOUBT, ASK ENGG. DEPT.

ALL DIMENSIONS ARE IN mm UNLESS OTHERWISE SPECIFIED.	MACHINING DEVIATION FOR OPEN DIMNS. S 2102 (Medium)	SURFACE FINISH SYMBOLS
OVER	±0.1	▽
UP TO & INCL.	±0.2	▽▽
TOLERANCE	±0.3	▽▽▽
	±0.5	▽▽▽▽
	±1.2	▽▽▽▽▽
	±2	▽▽▽▽▽▽
	±3	▽▽▽▽▽▽▽
	>4000	▽▽▽▽▽▽▽▽
		ROUGHNESS SYMBOL
		ROUGHNESS VALUE IN μm
		N1 0.025
		N2 0.05
		N3 0.1
		N4 0.2
		N5 0.4
		N6 0.8
		N7 1.6
		N8 3.2
		N9 6.3
		N10 12.5
		N11 25
		N12 50